

## Schemi montaggio *Assembling diagrams*

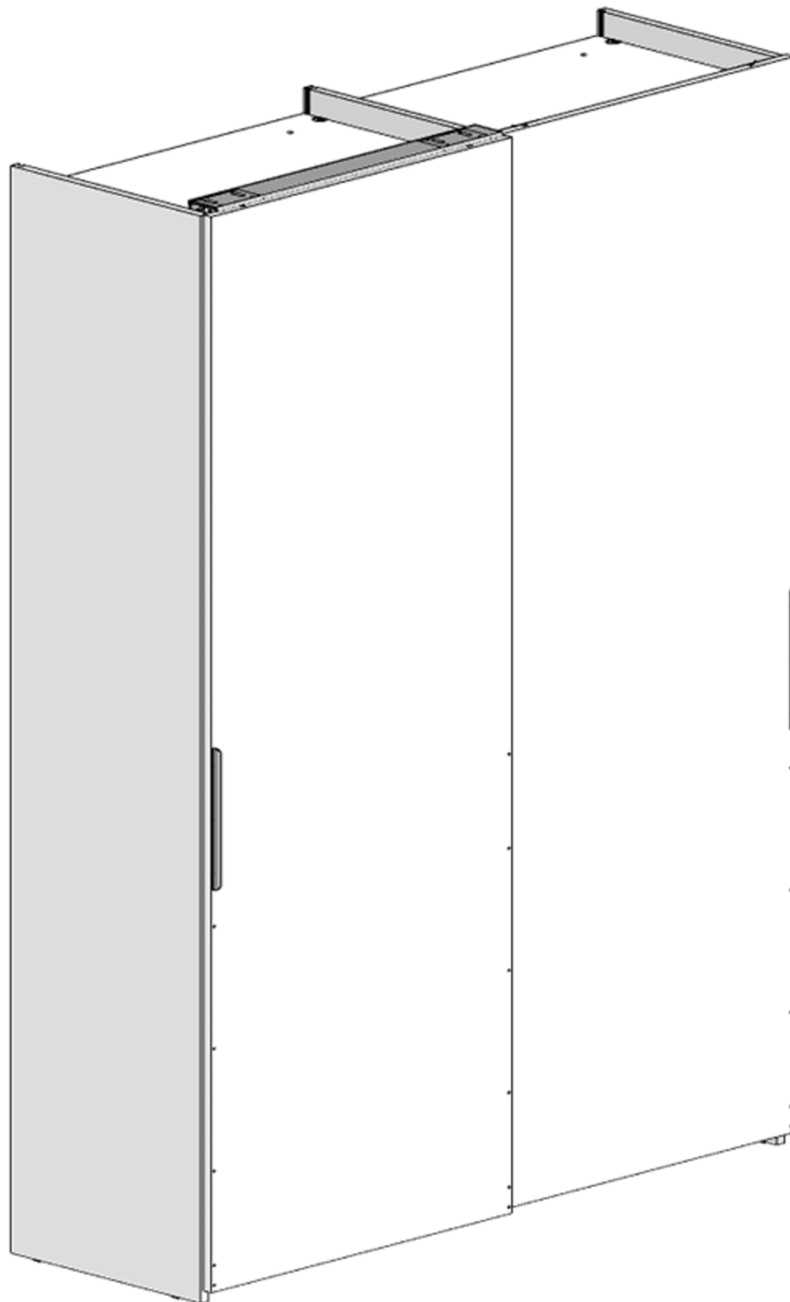



**SLIDER**



ed. 02/2016 -rev. 1

SCMNT035

2X

080005146 - SFR_Sc.Fr.Pied.Base.Mod.Slide				
200002014	A		n°4	

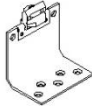
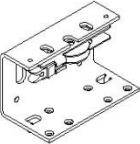
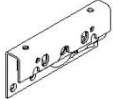
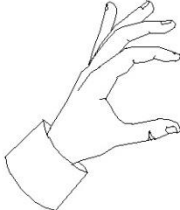

080005086 - SFR_Sac.Fr.Scor.Fiss.Guid2Ant.				
200000968	B		n°12	





200000246 - SFR_SAC.FR.SCORR.CARREL.2ANTE				
C		n°45		
D		n°2		
E		n°2		
F		n°2		
G		n°2		

200000249 - SFR_SAC.FR.SCOR.KIT RALL.2ANTE				

3X

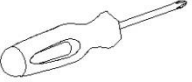
080005146 - SFR_Sc.Fr.Pied.Base.Mod.Slide				
200002014	A		n°4	

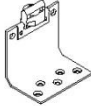
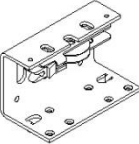
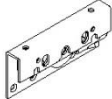
080005087 - SFR_Sac.Fr.Scor.Fiss.Guid3Ant.				
200000968	B		n°18	

200000247 - SFR_SAC.FR.SCORR.CARREL.3ANTE				
C		n°66		
D		n°4		
E		n°2		
F		n°2		
G		n°4		

200000250 - SFR_SAC.FR.SCOR.KIT RALL.3ANTE				

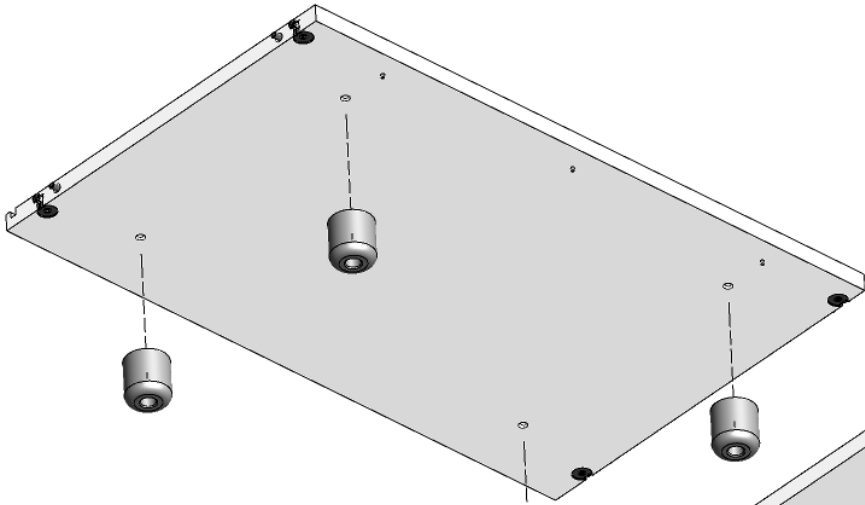

A

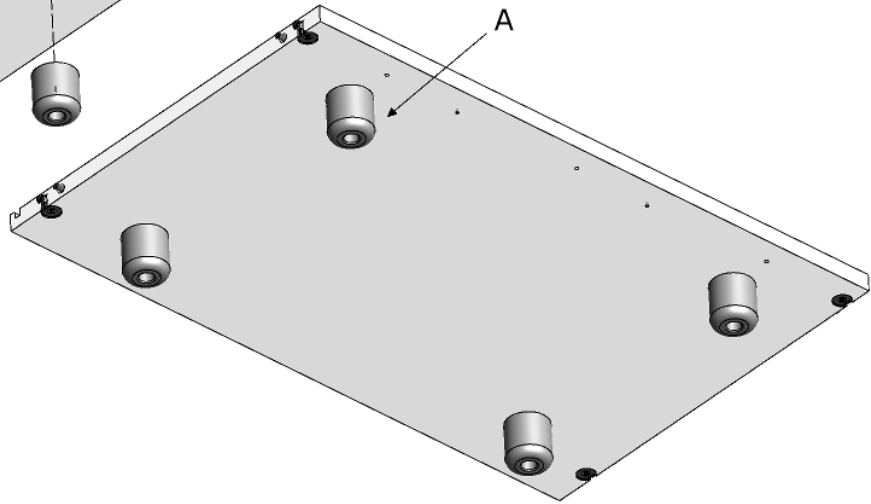

A

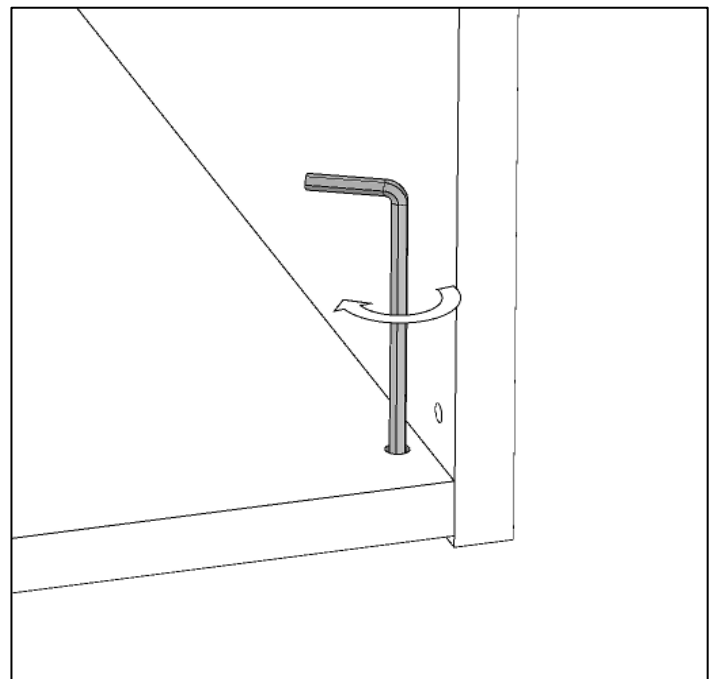
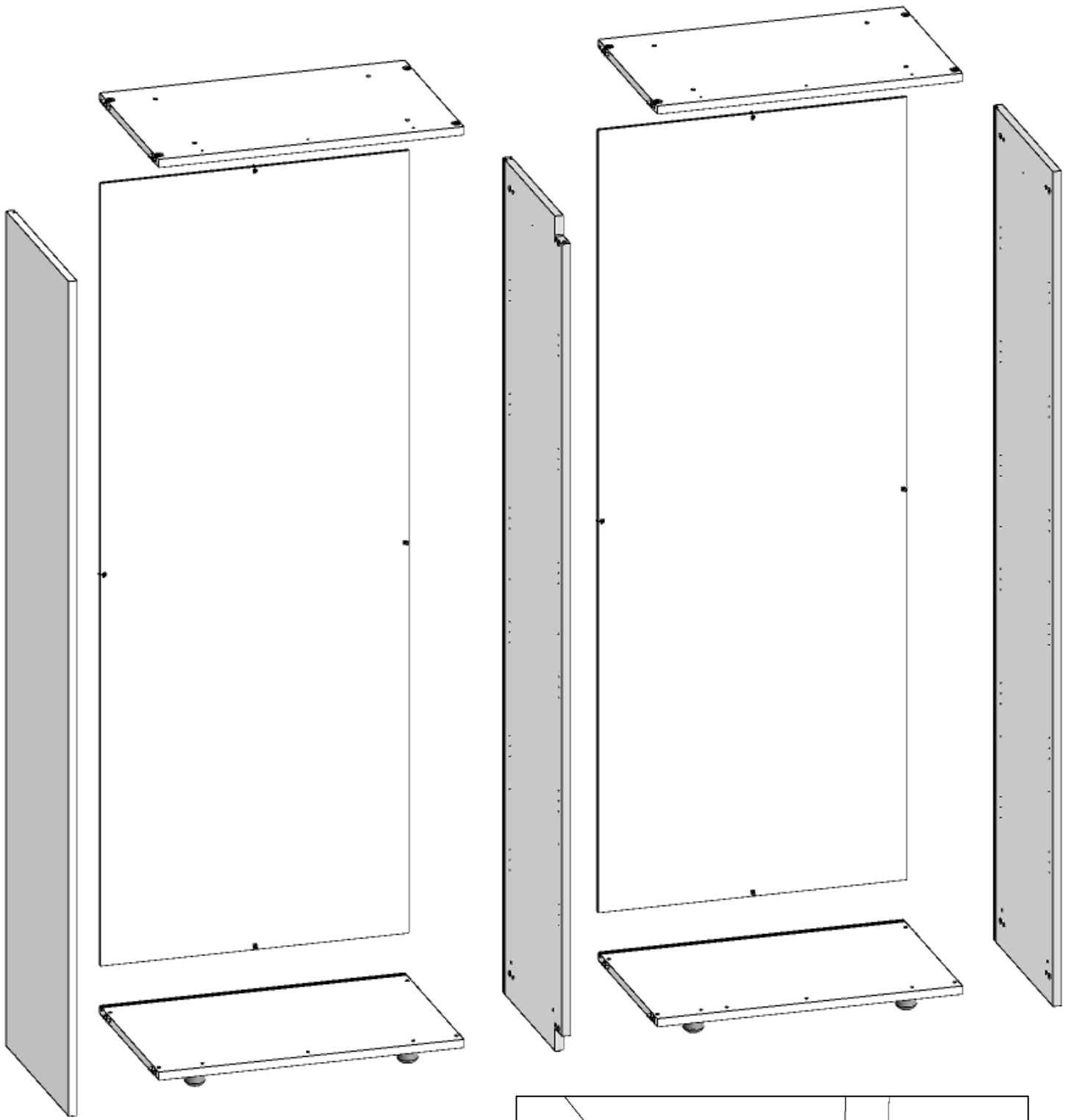

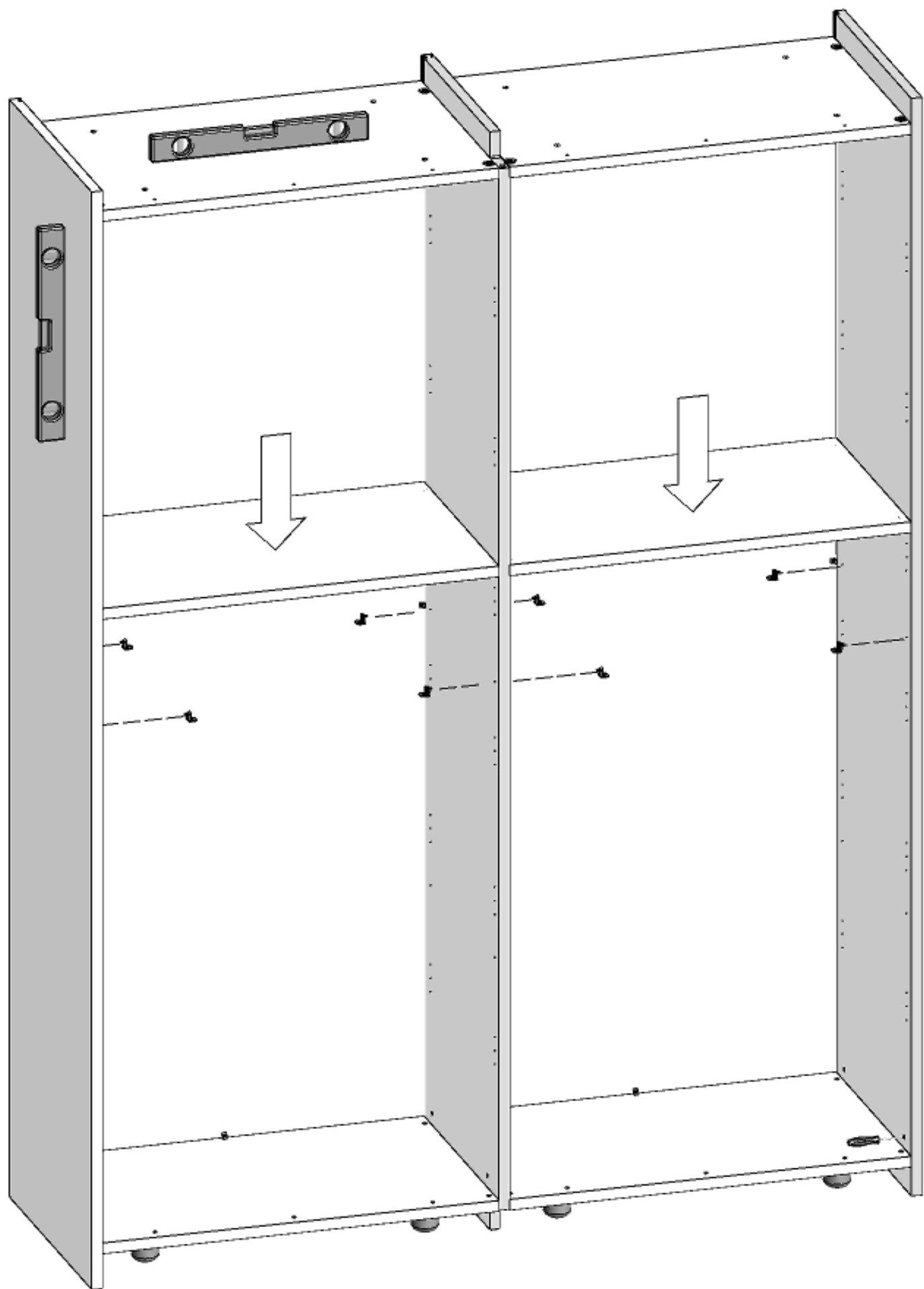

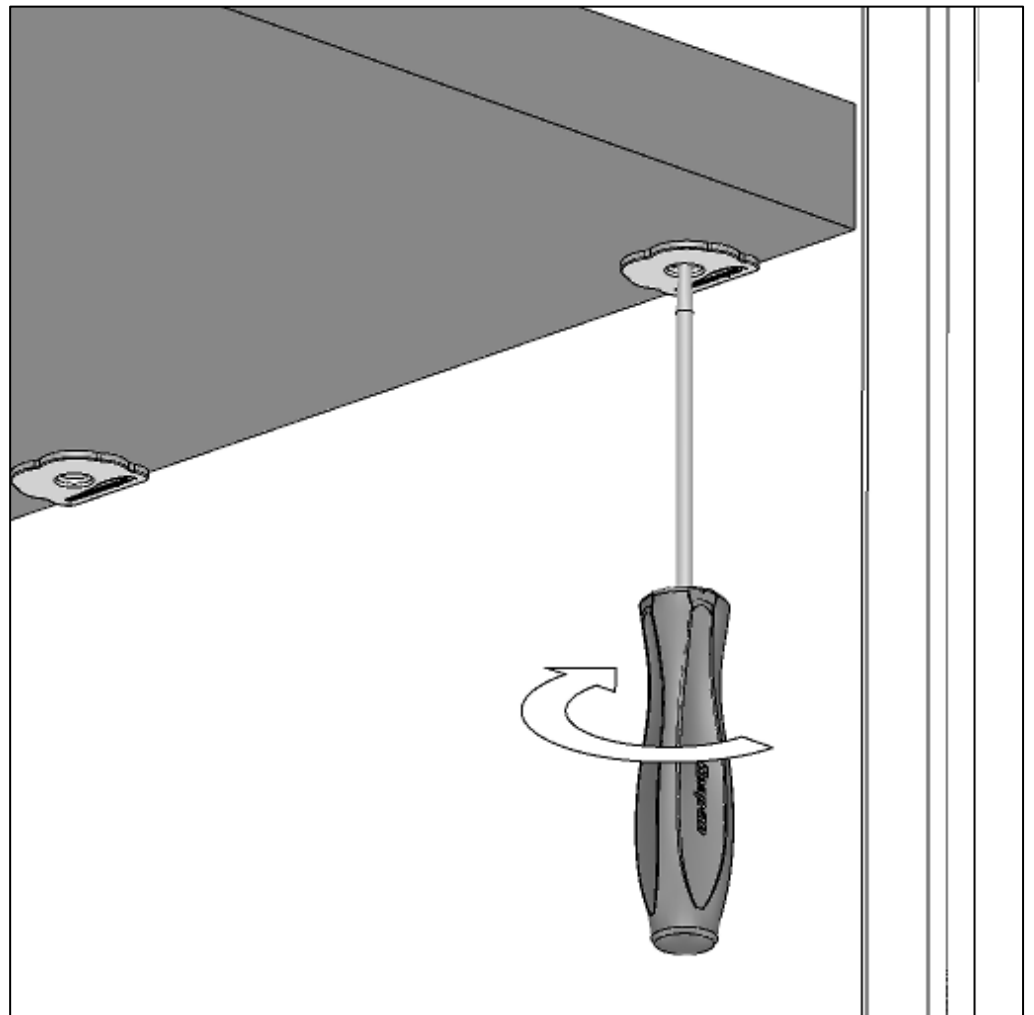
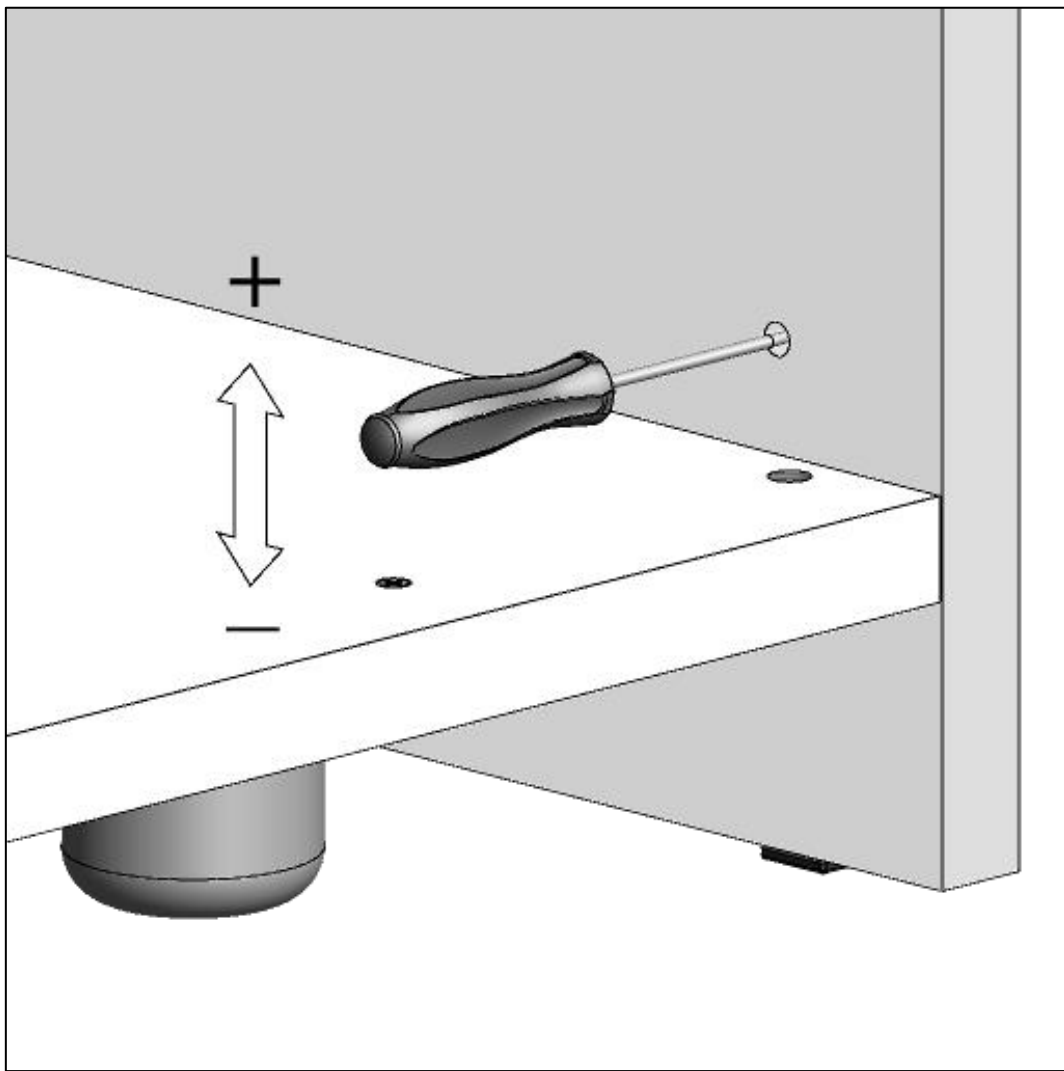

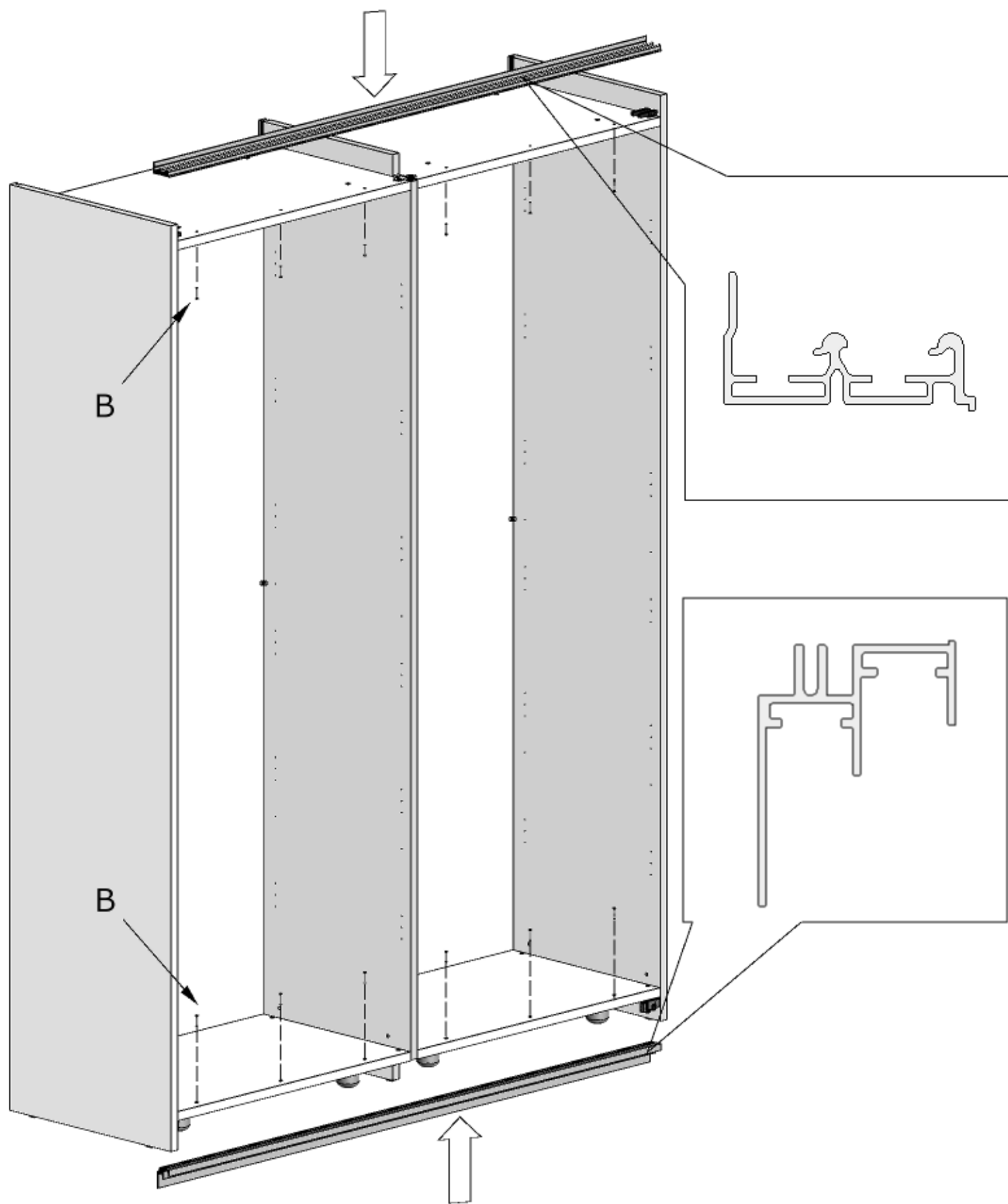

SX

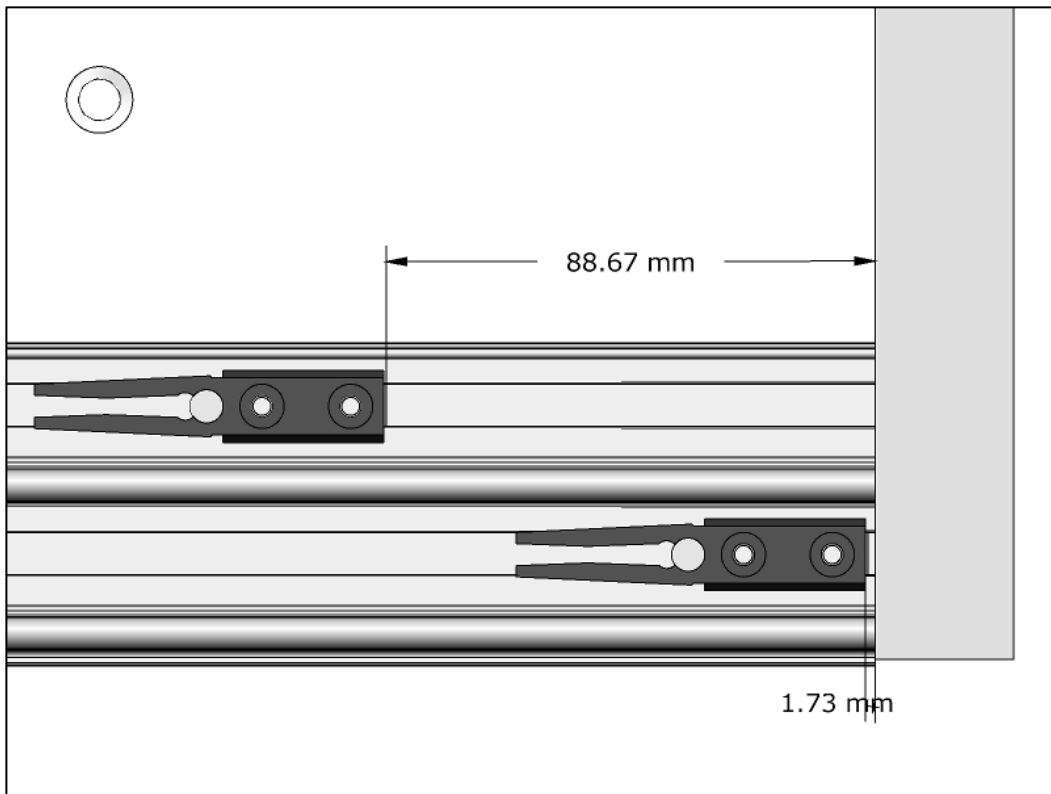
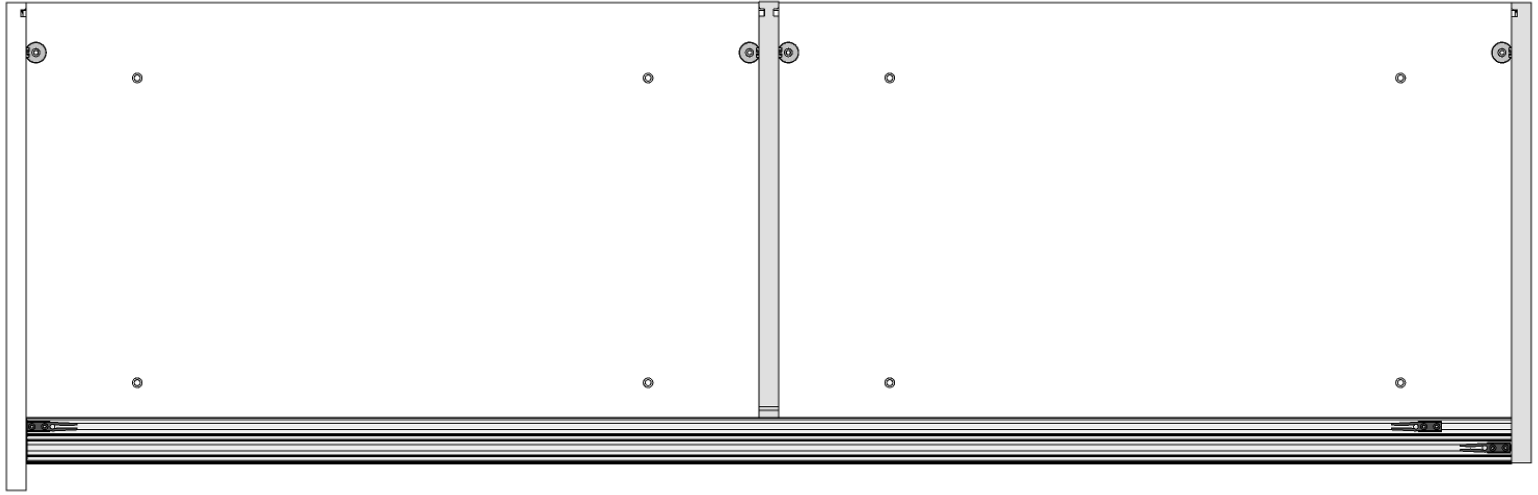



# DX

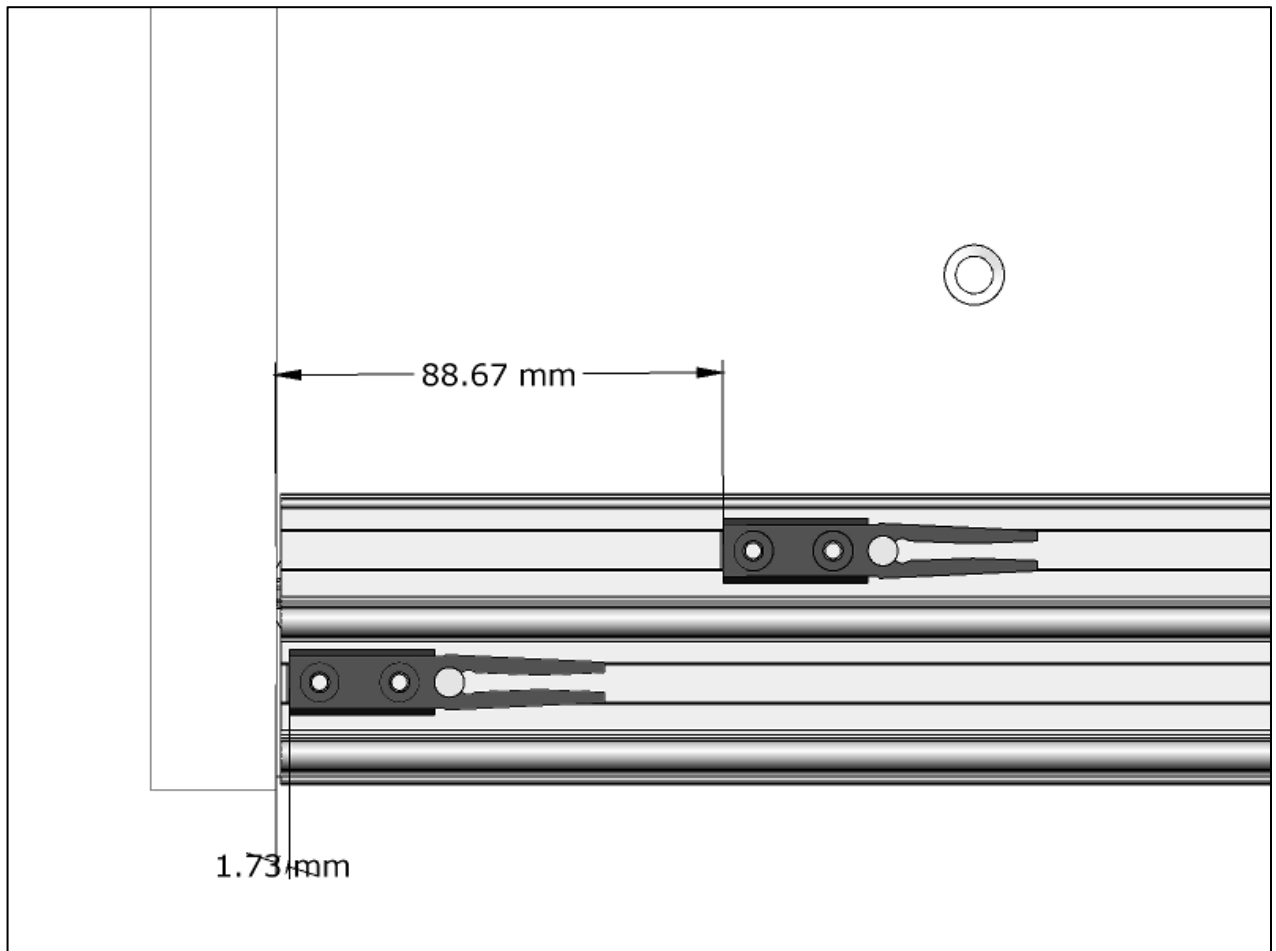
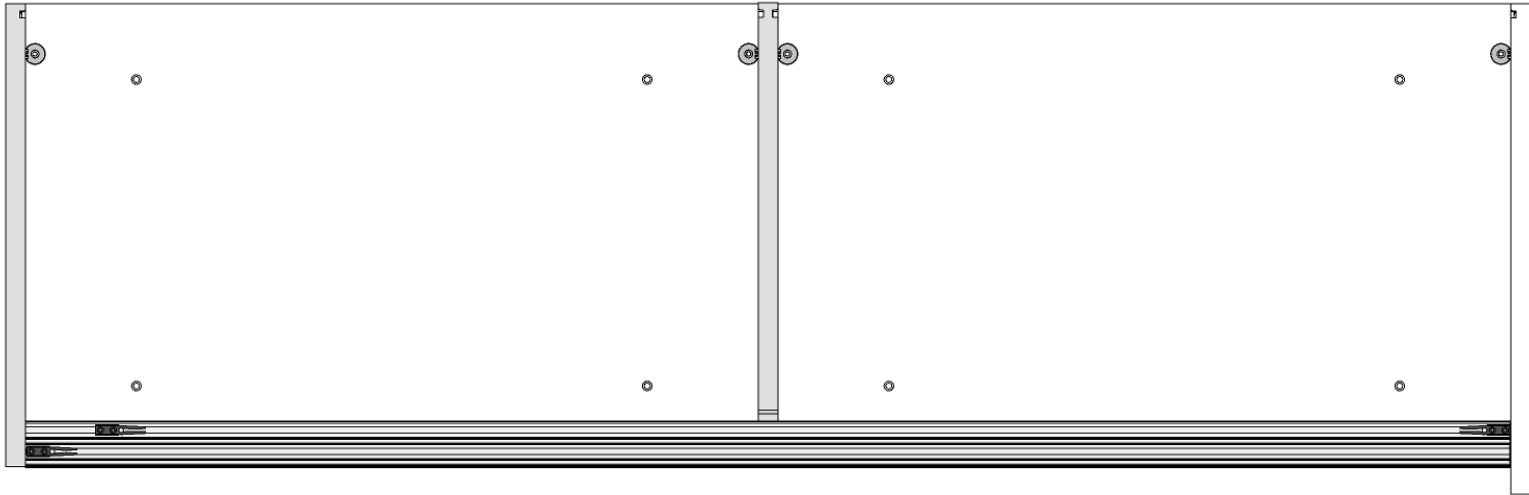

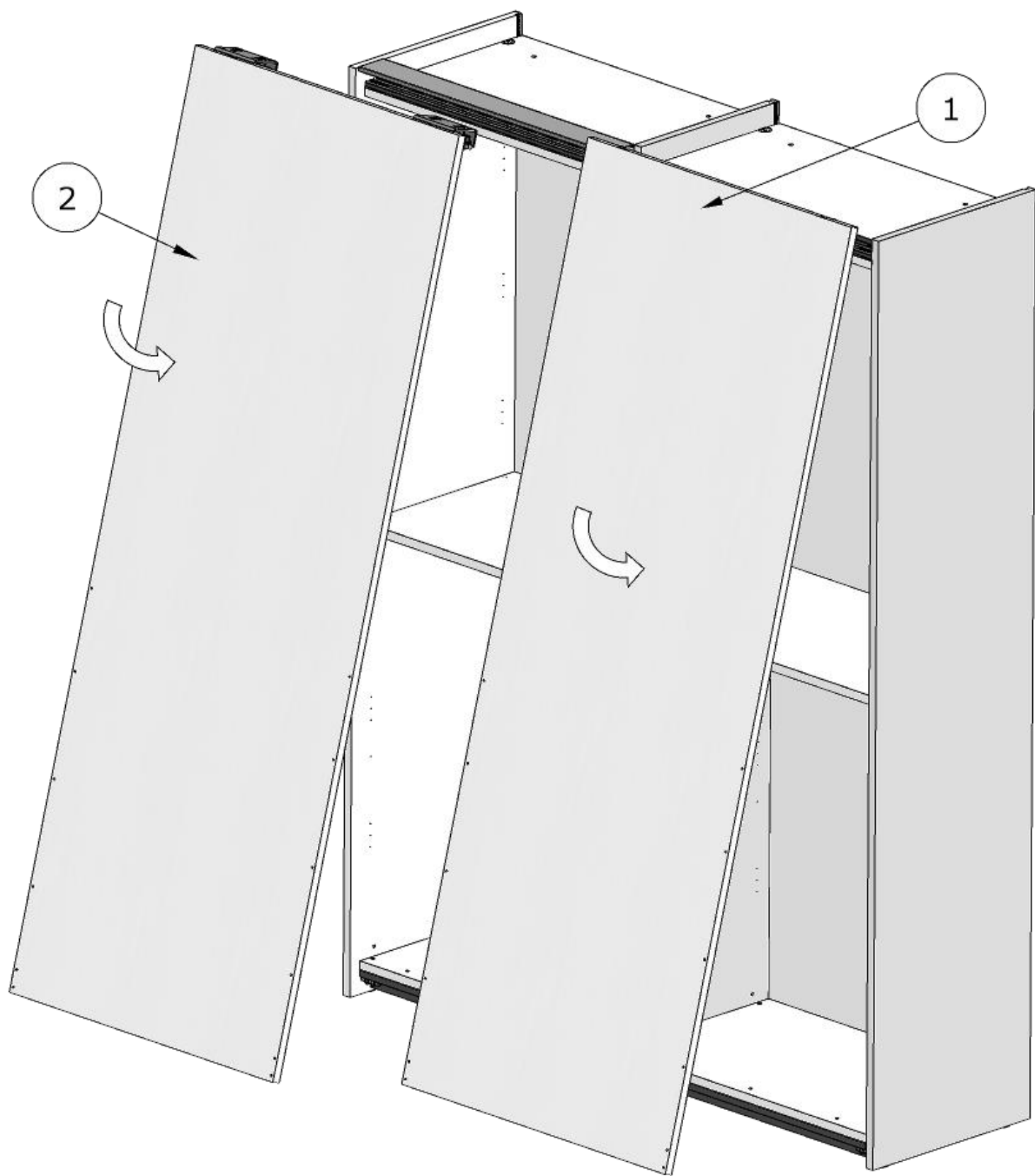

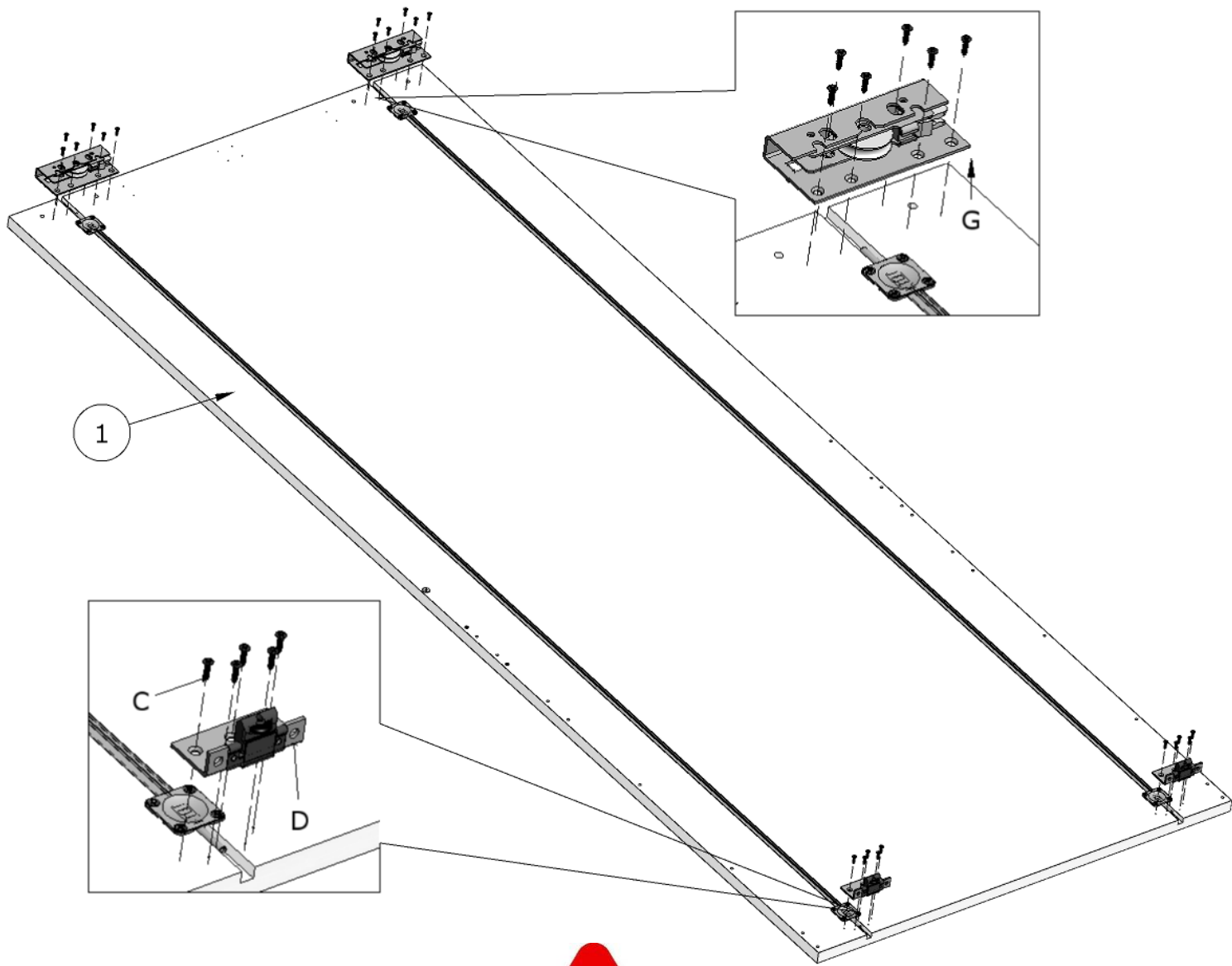

SI

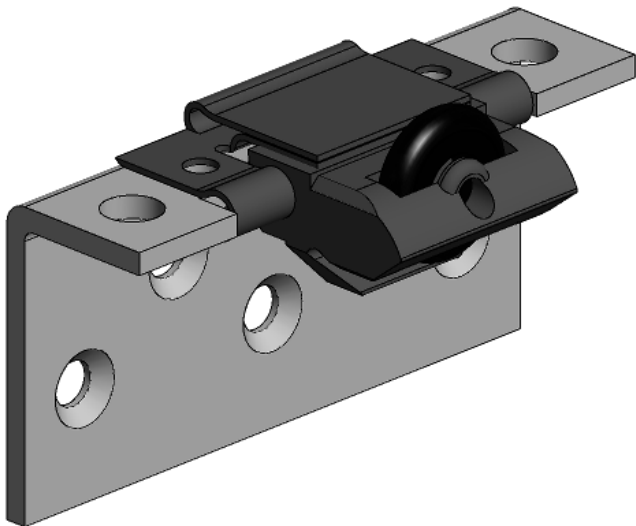

NO

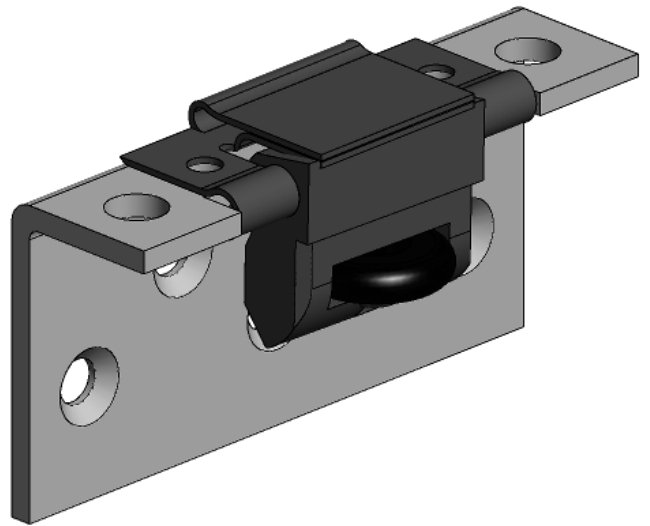

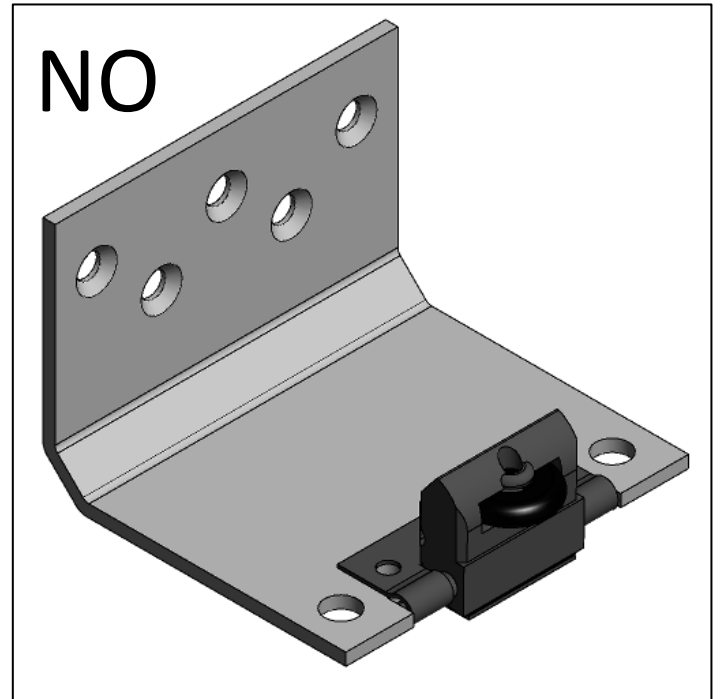
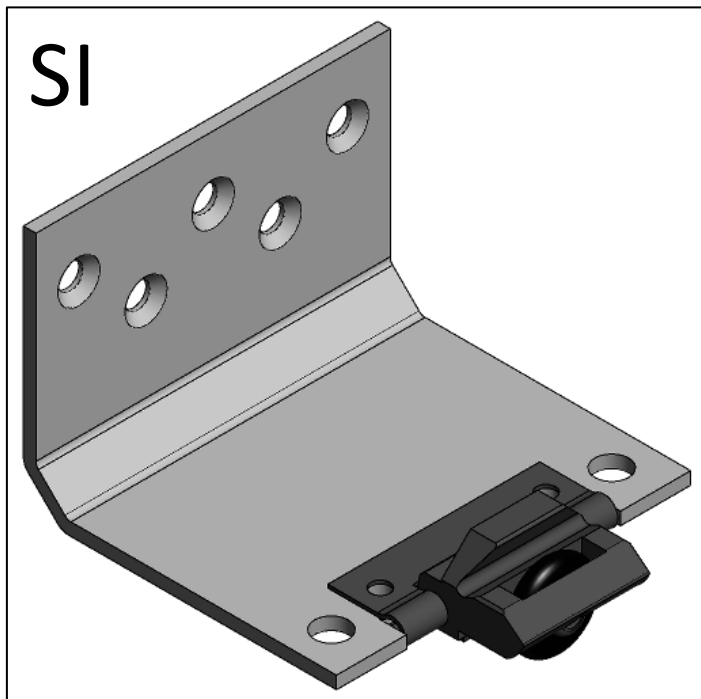
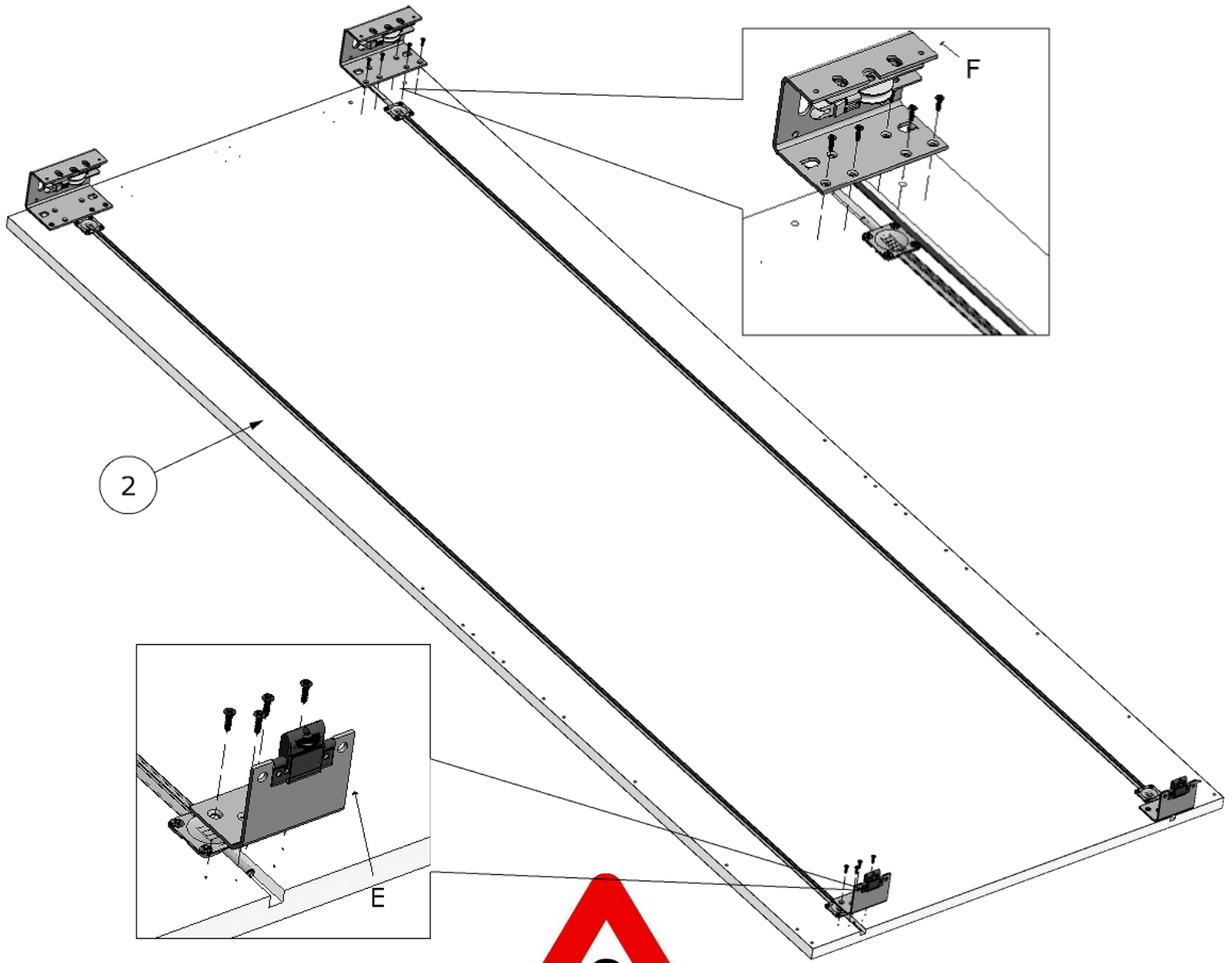

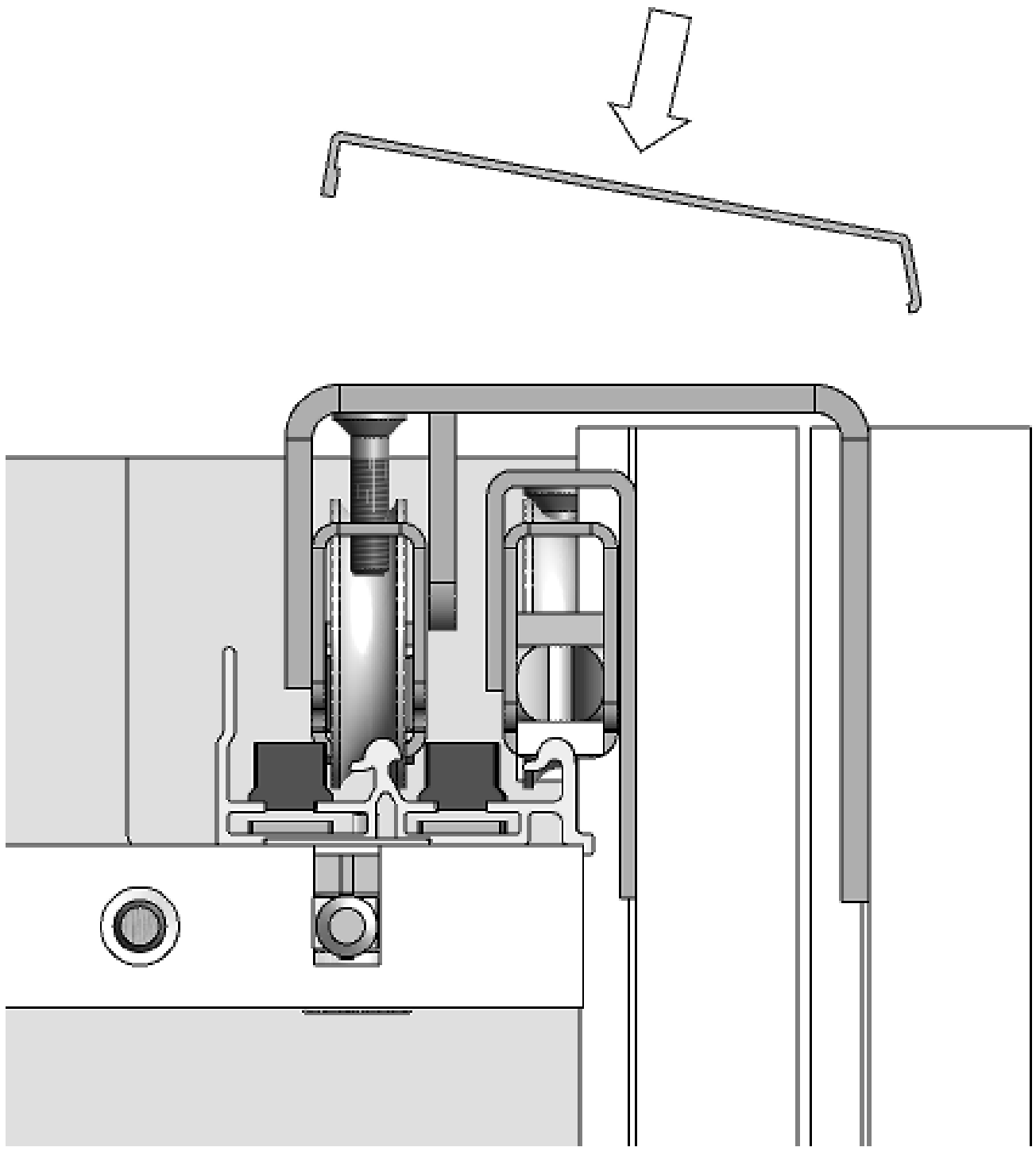

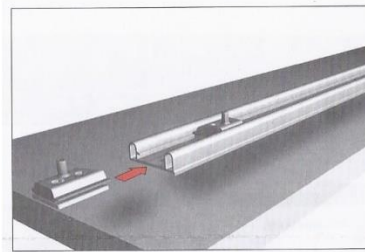



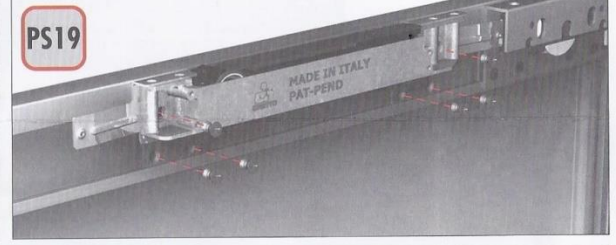
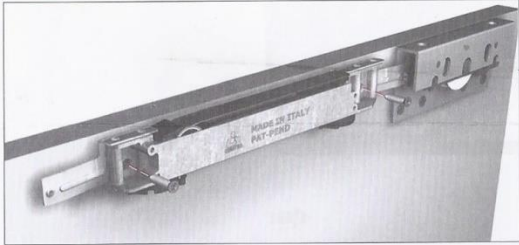

**ANTA  
INTERNA  
INTERNAL  
DOOR**

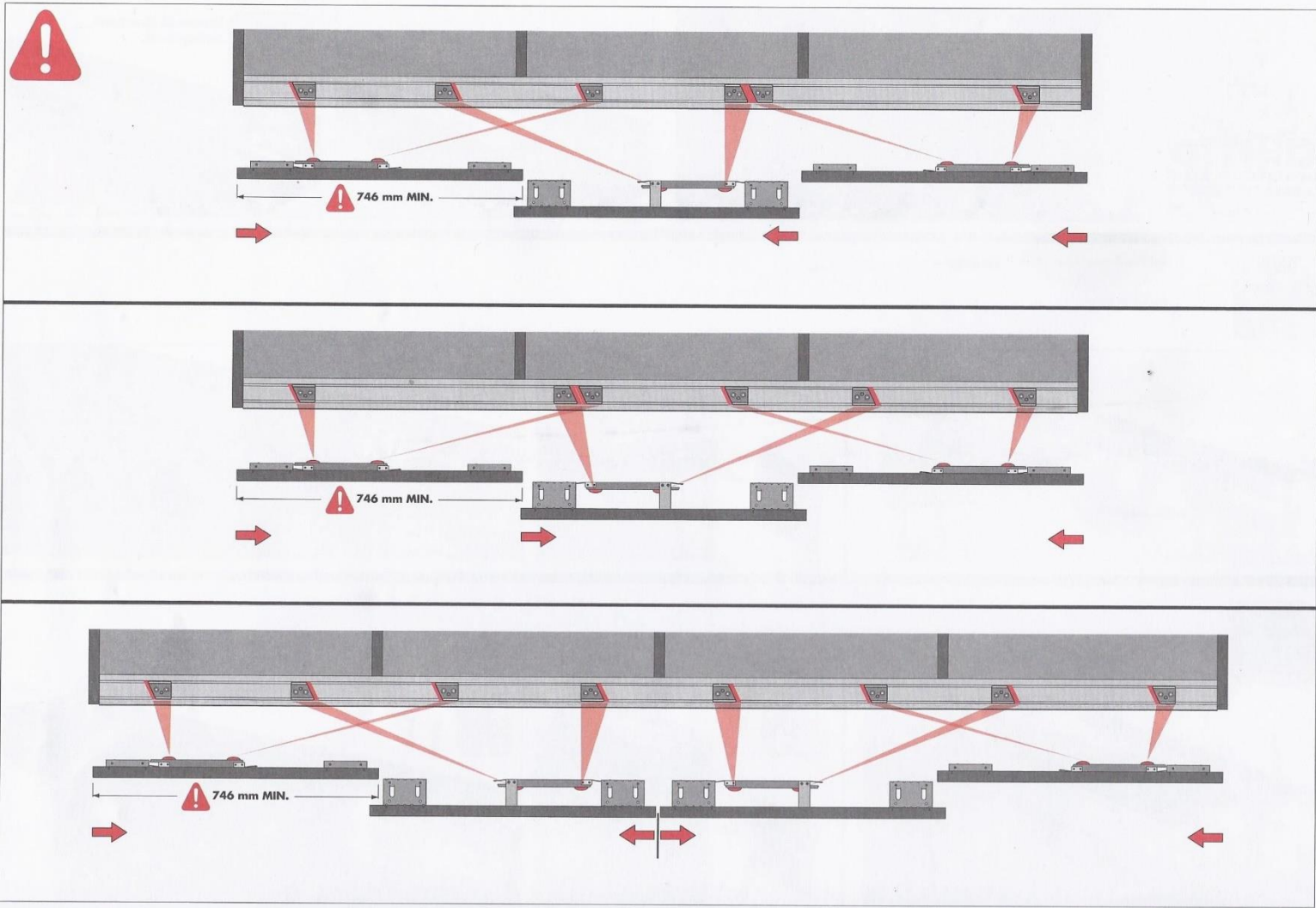
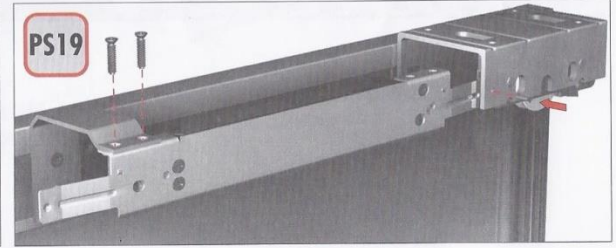
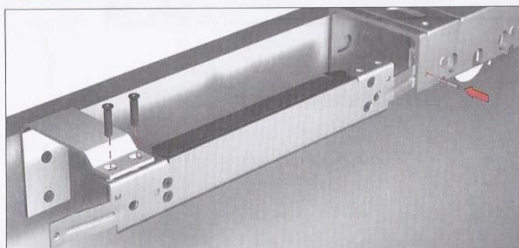

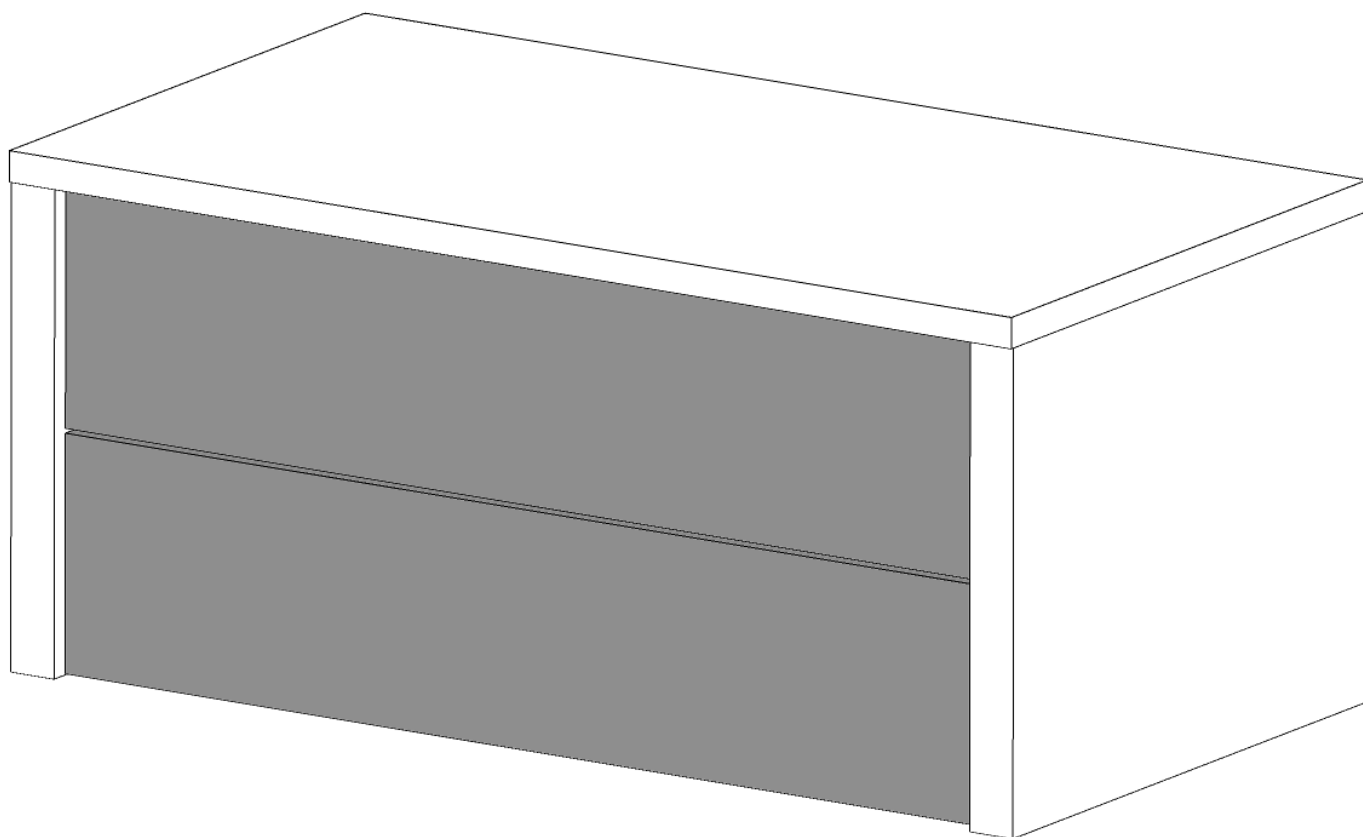
**ANTA  
ESTERNA  
EXTERNAL  
DOOR**



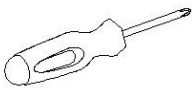

080005062 - SFR_Sac.Fr.Cassettiera Intern2				
200000653	A		n°4	
200000953	B		n°4	

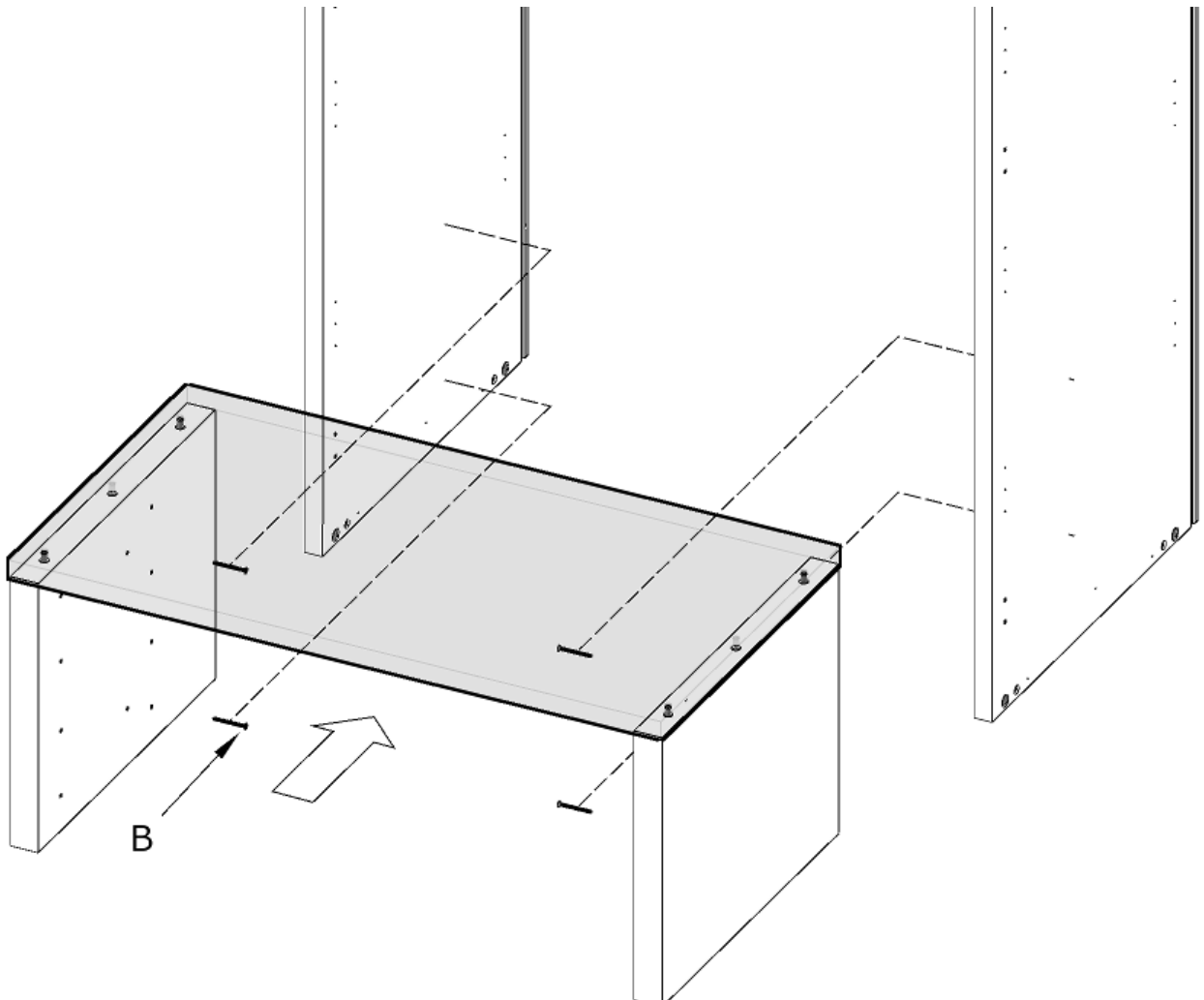
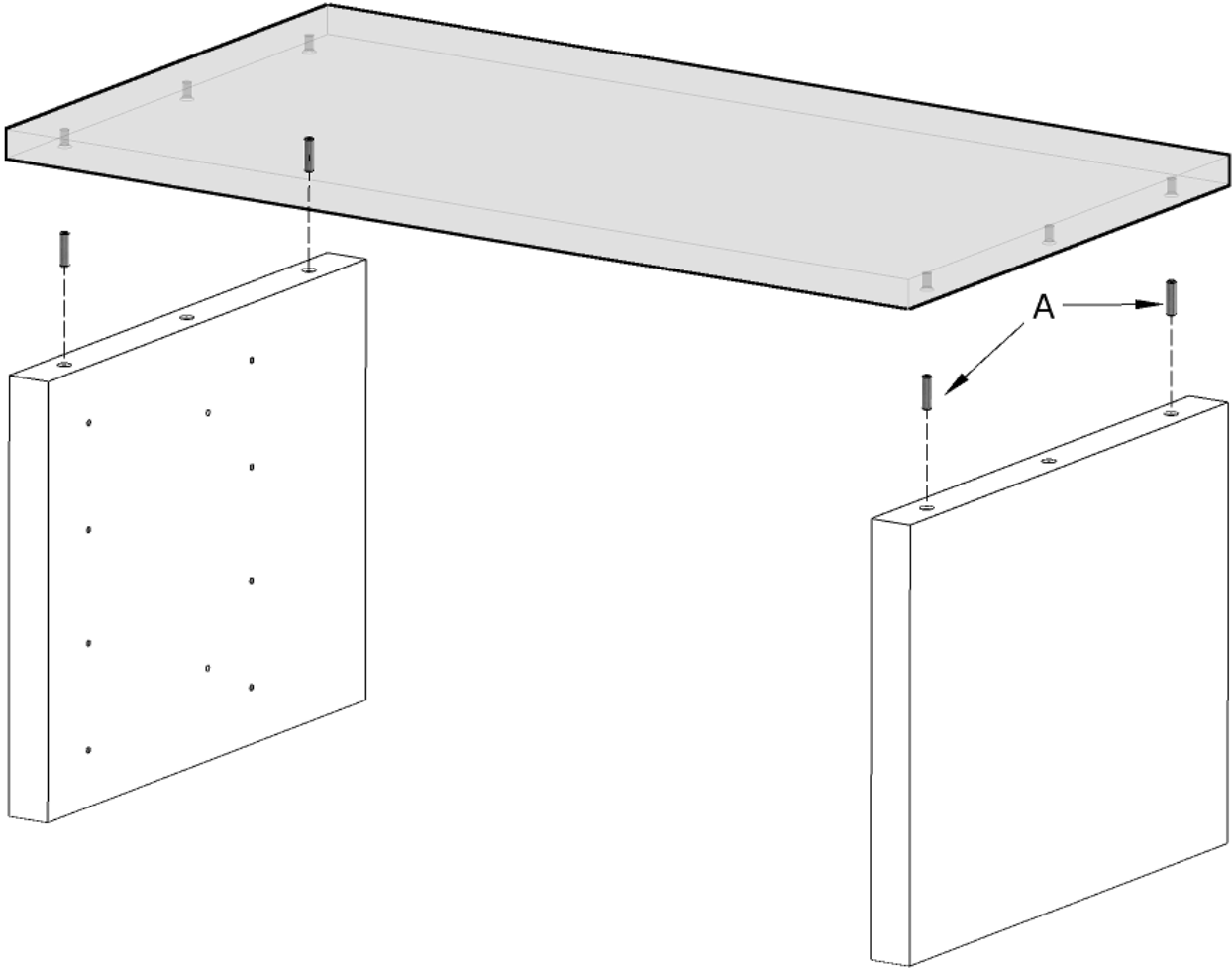



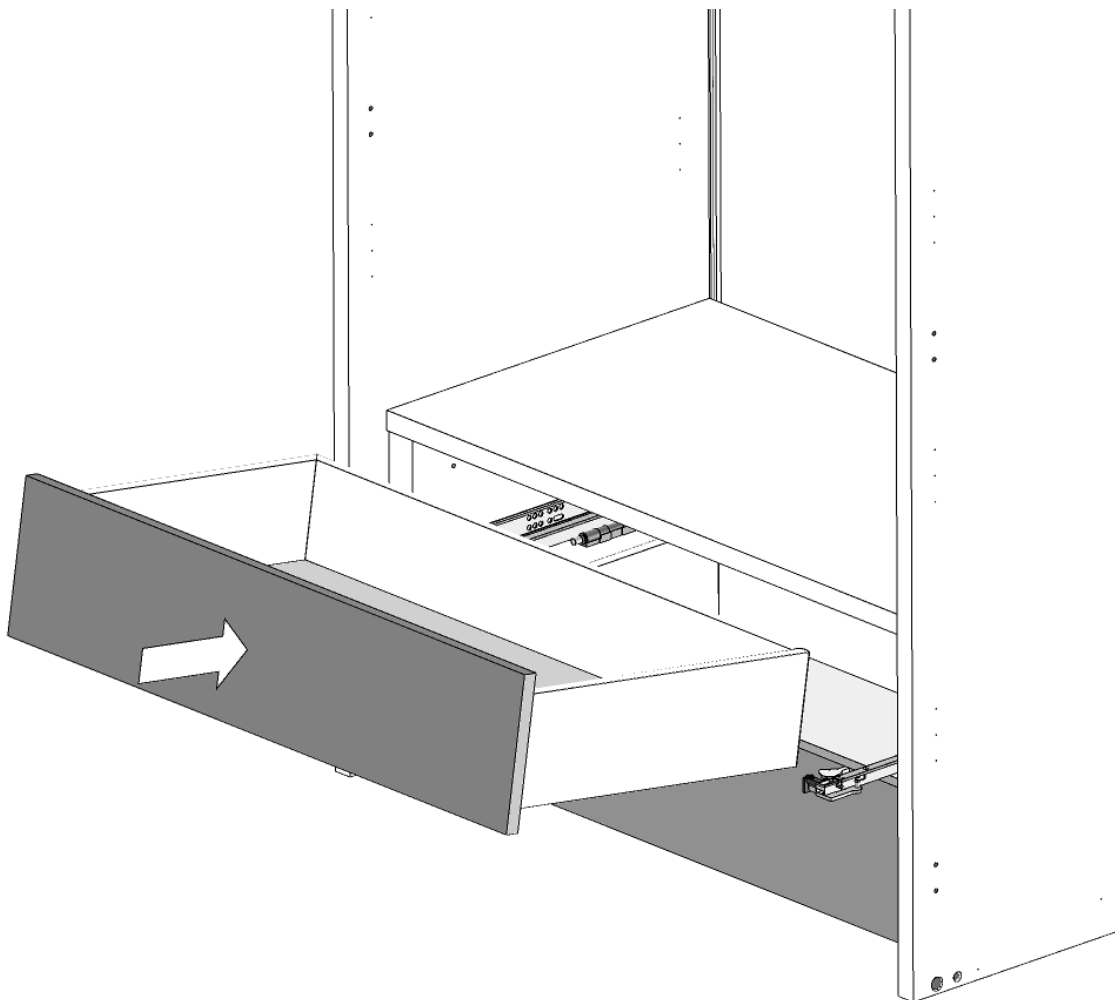
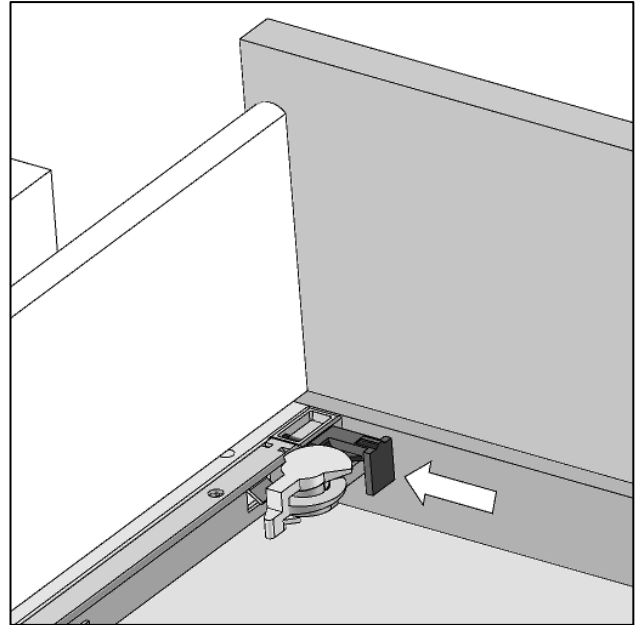
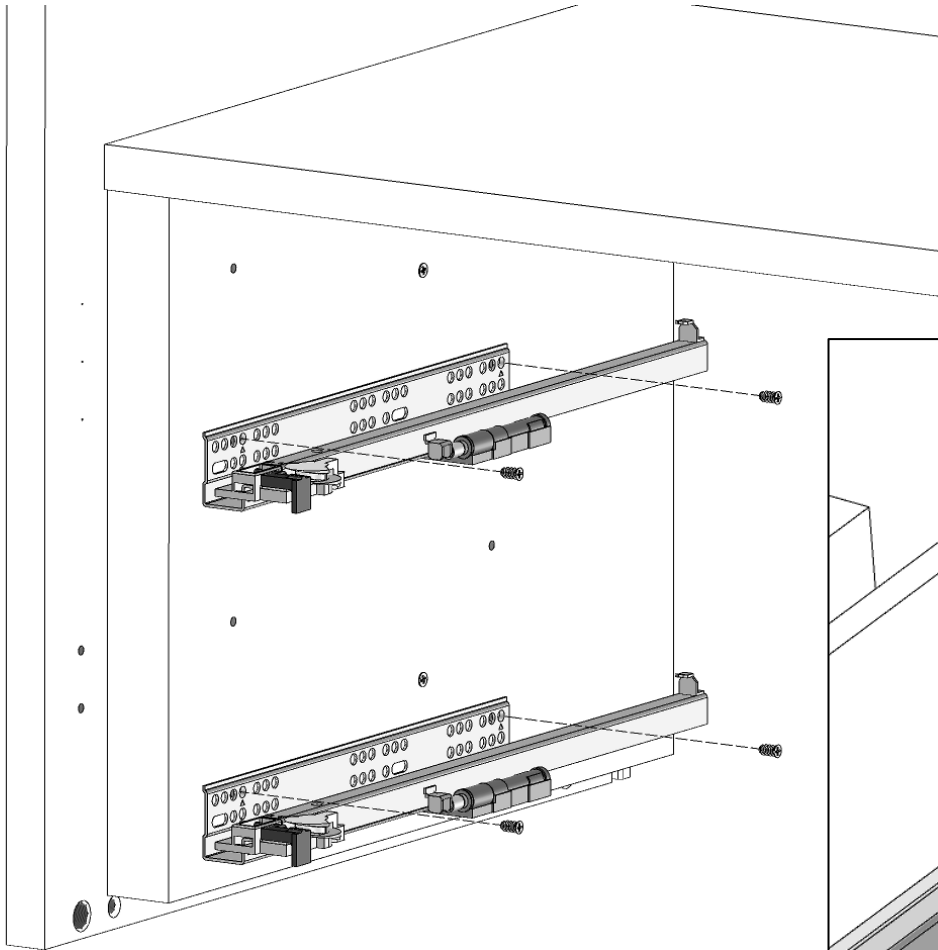

Ruotare la rotella nera verso il frontale del cassetto per aumentare l'aria tra il frontale e il fianco.

Questa operazione si effettua senza l'utilizzo di alcun utensile.

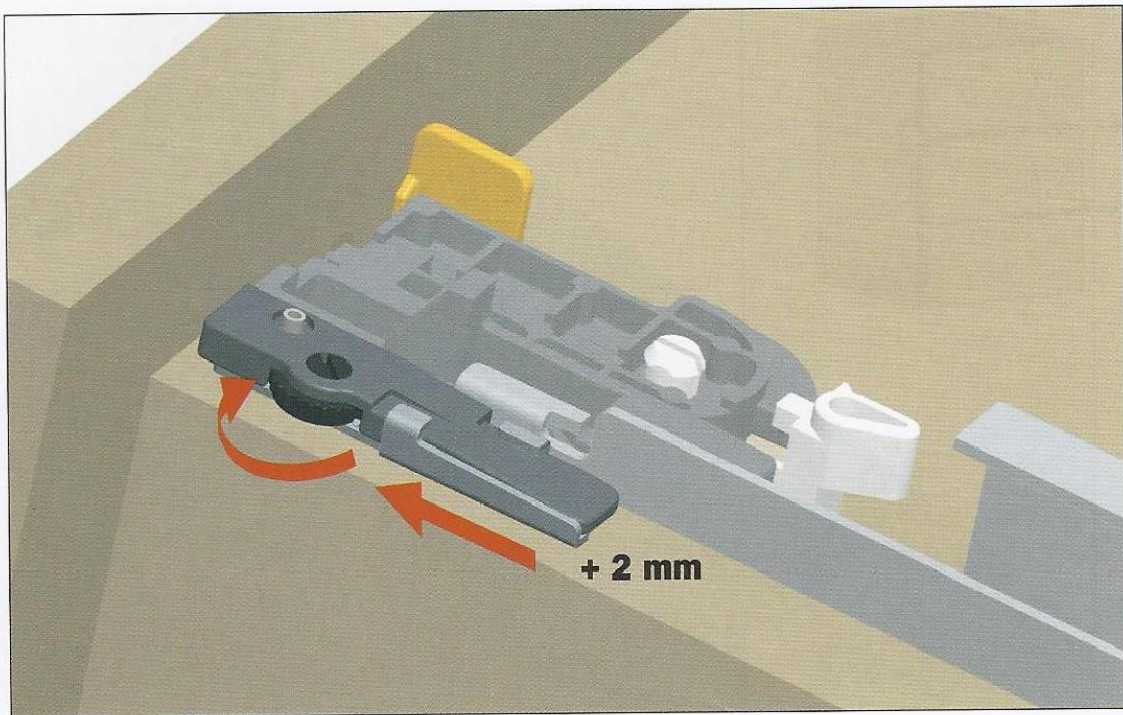
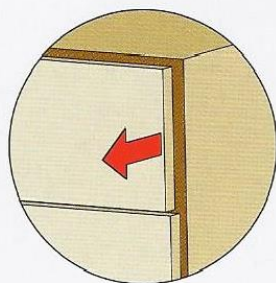
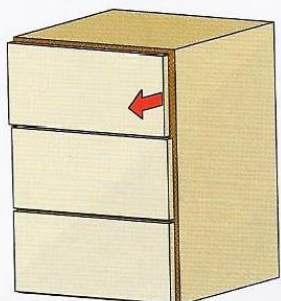

Ruotare la rotella nera verso il retro del cassetto per diminuire l'aria tra il frontale e il fianco.

Questa operazione si effettua senza l'utilizzo di alcun utensile.

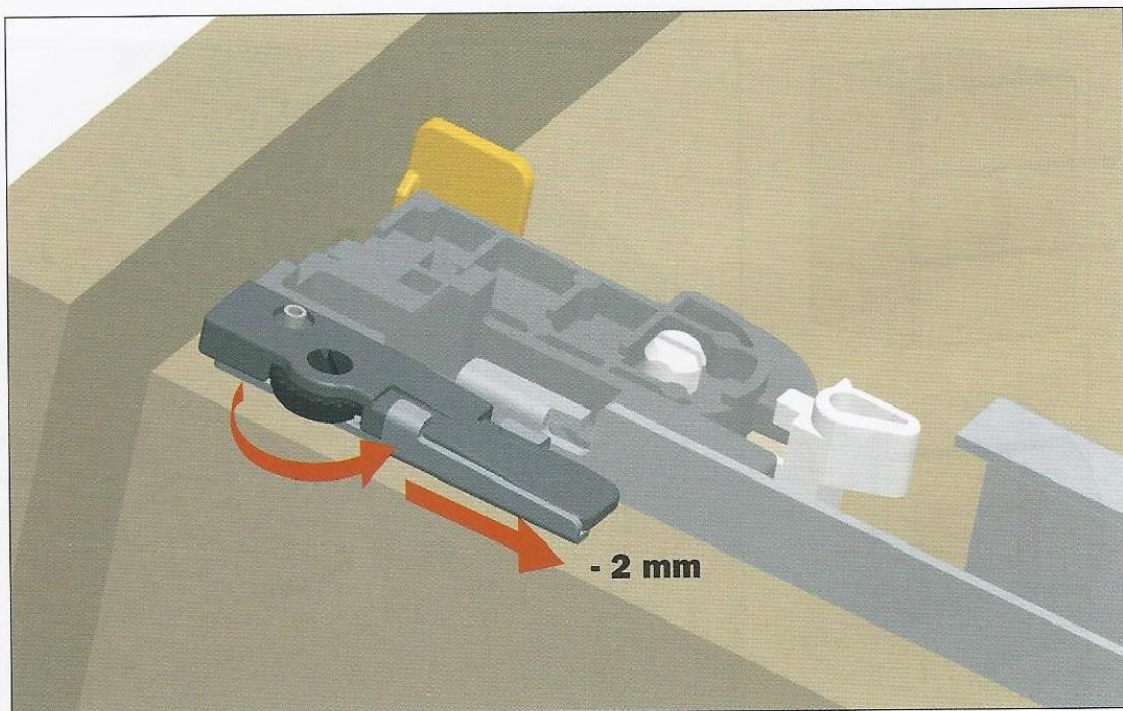
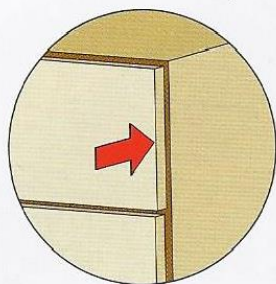
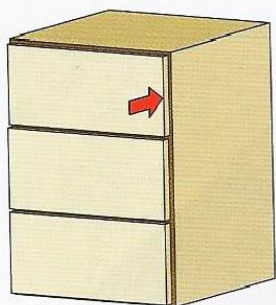



Posizione iniziale della leva per la regolazione verticale.

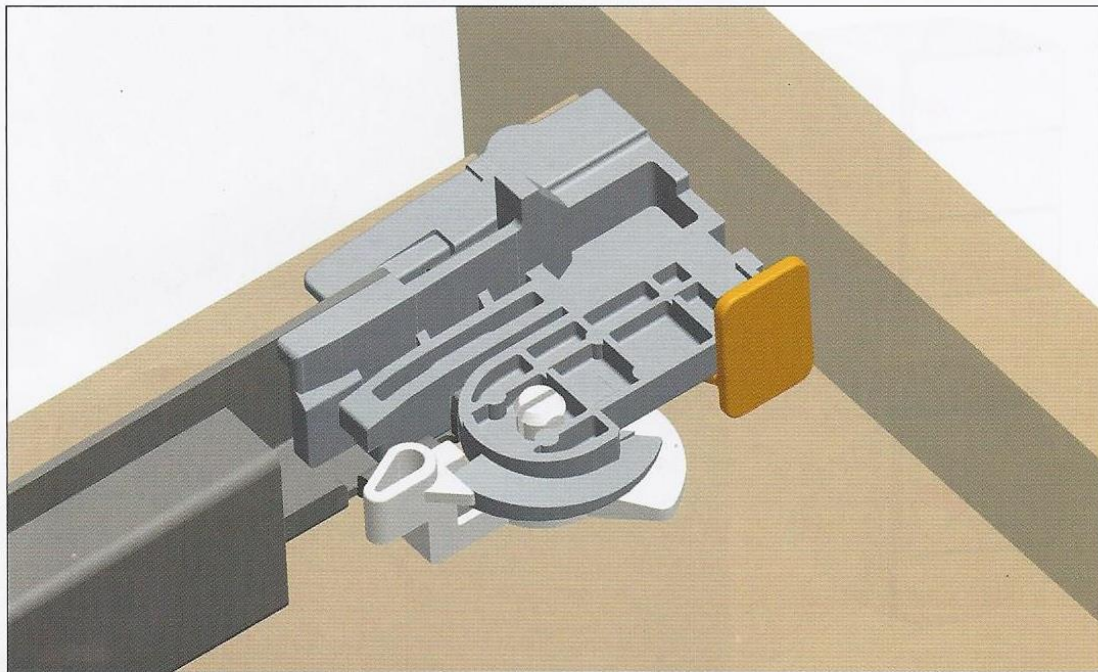
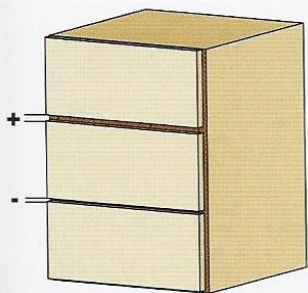

Ruotare la leva verso il frontale del cassetto per ottenere la regolazione verticale.

Questa operazione si effettua senza l'utilizzo di alcun utensile.

