

Schemi montaggio *Assembling diagrams*

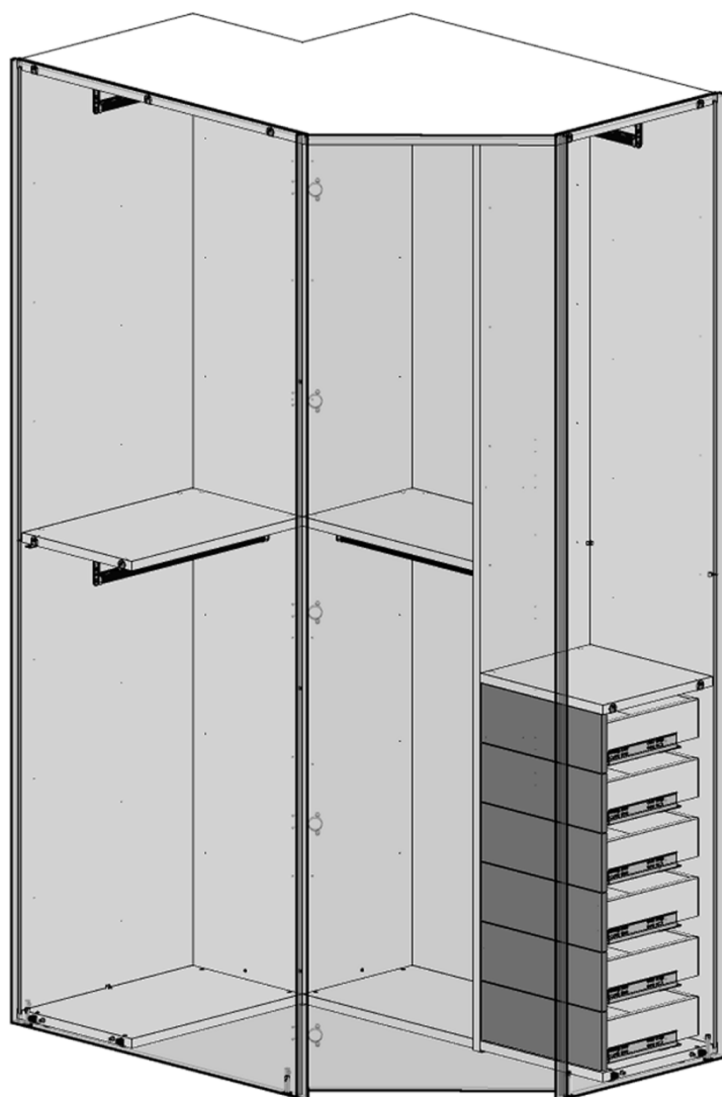

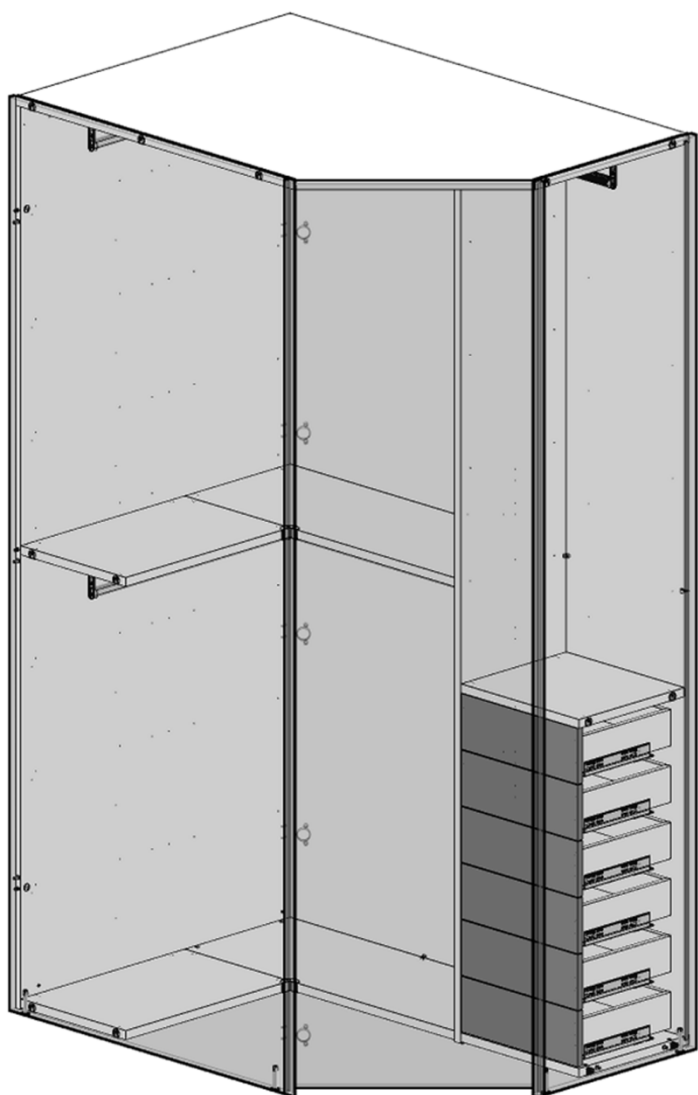



CABINA WIDE

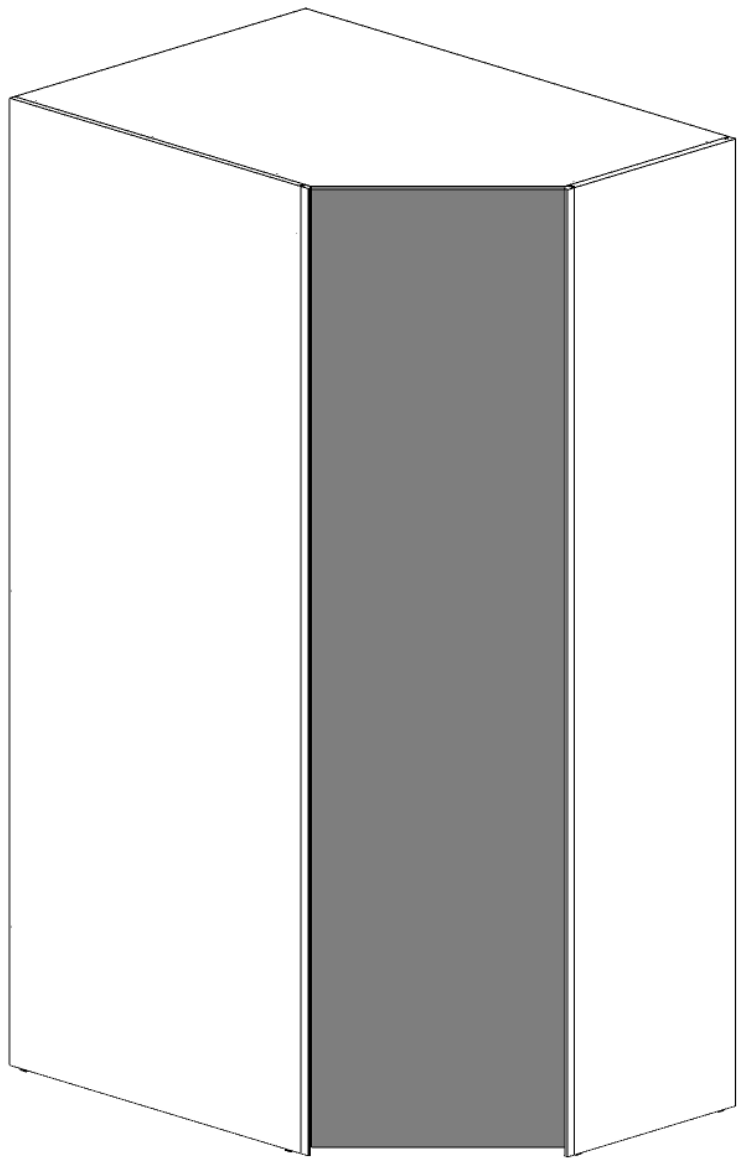

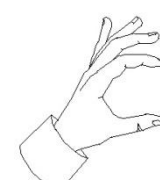
ed. 02/2016 - rev. 1



SCMNT014







080005837 - SFR_Sac.Fr.Strt.Wide				
200000666	A		n°8	
200000653	B		n°3	
200002161	C		n°1	



080005145 - SFR_Sac.Fr.Pied.Base.Mod.Std				
200001980	G		n°4	

080005770 - SFR_Sac.Fr.TAB a "T" Ripiani				
200000683	H		n°1	
200000938	I		n°2	

080005160 - SFR_Sac.Fr.Allinea.Rip.Cabina				
200002138	E		n°1	
200000942	F		n°2	

REGGIRIPIANO				
	L		n°21	

080005160 - SFR_Sac.Fr.Allinea.Rip.Cabina				
200002138	E		n°1	
200000942	F		n°2	

080005072 - SFR_Sac.Fr.Batt.Ante Alul.Cab				
200001381	M		n°1	
200000945	N		n°2	

080005145 - SFR_Sac.Fr.Pied.Base.Mod.Std				
200001980	G		n°4	

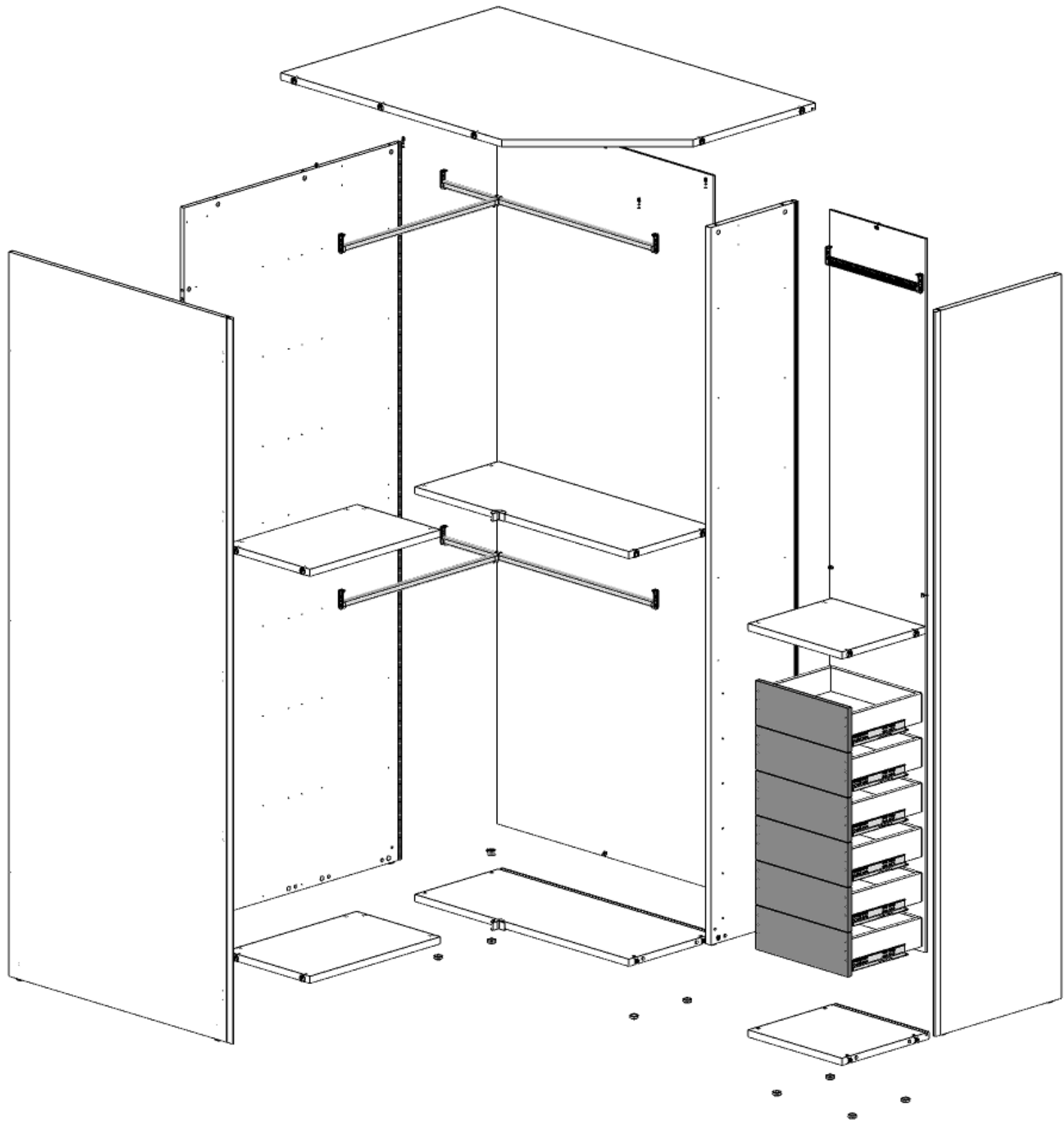

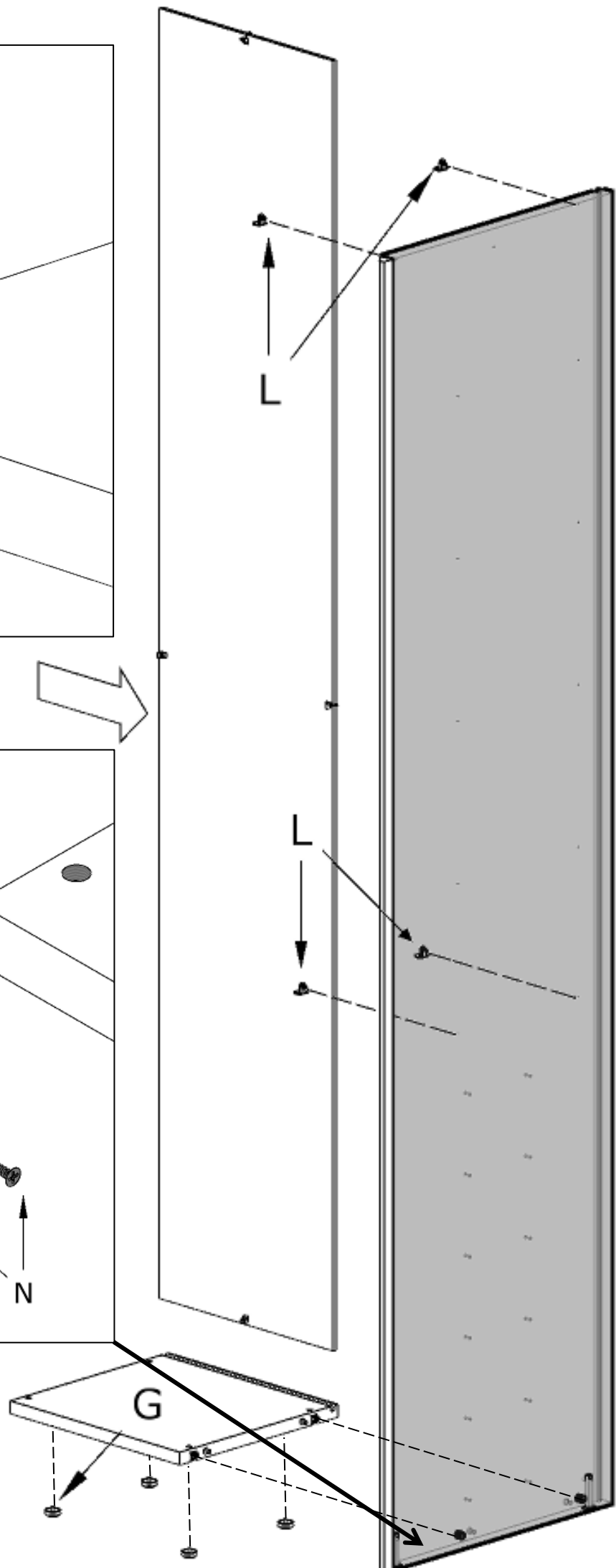
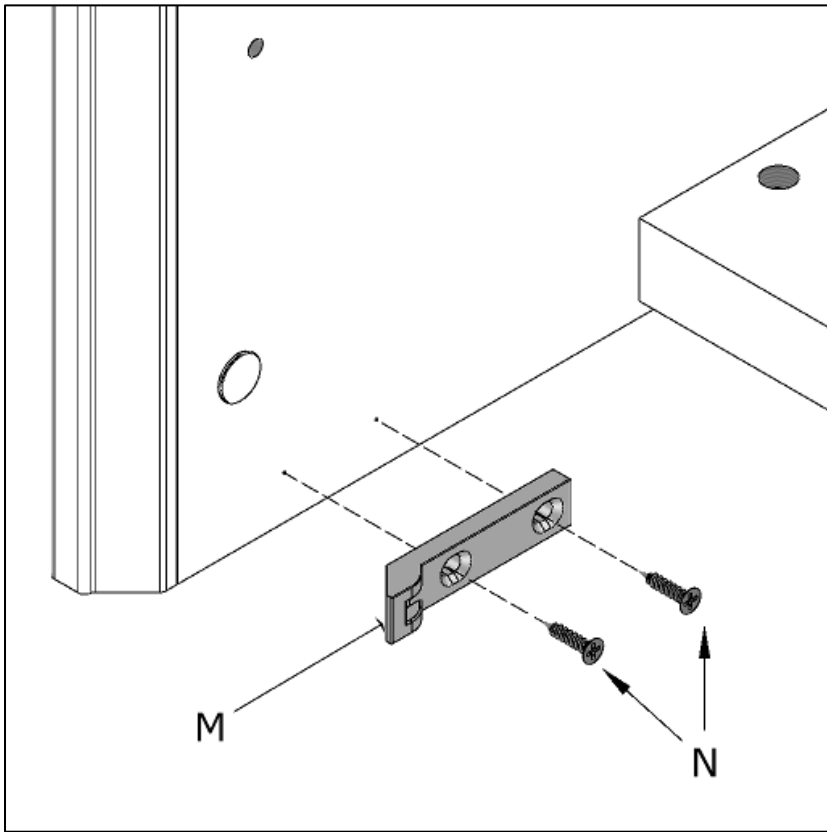
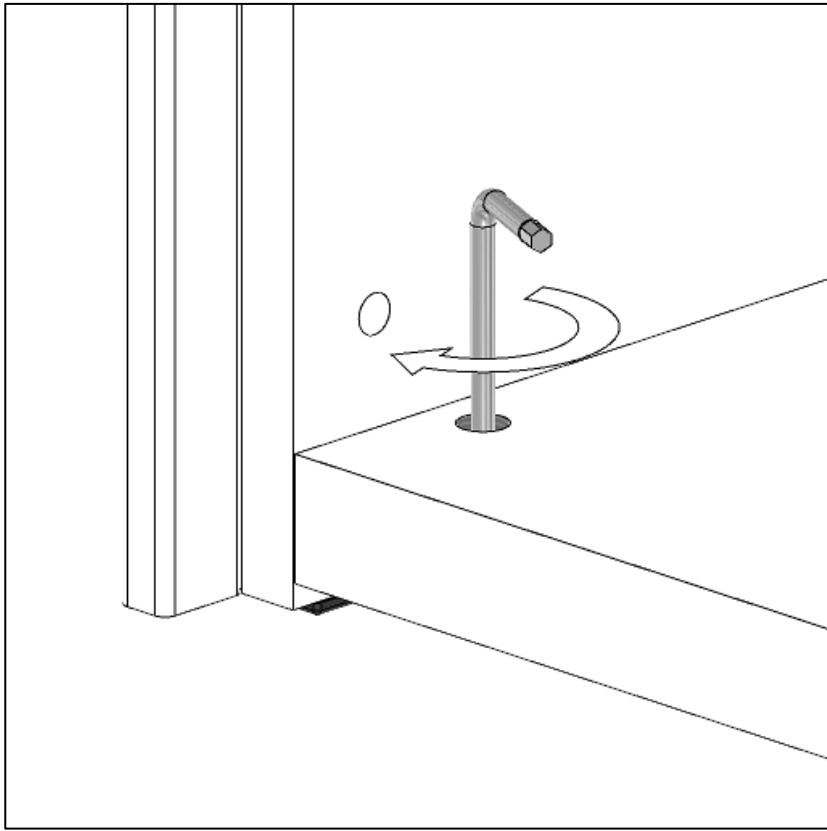

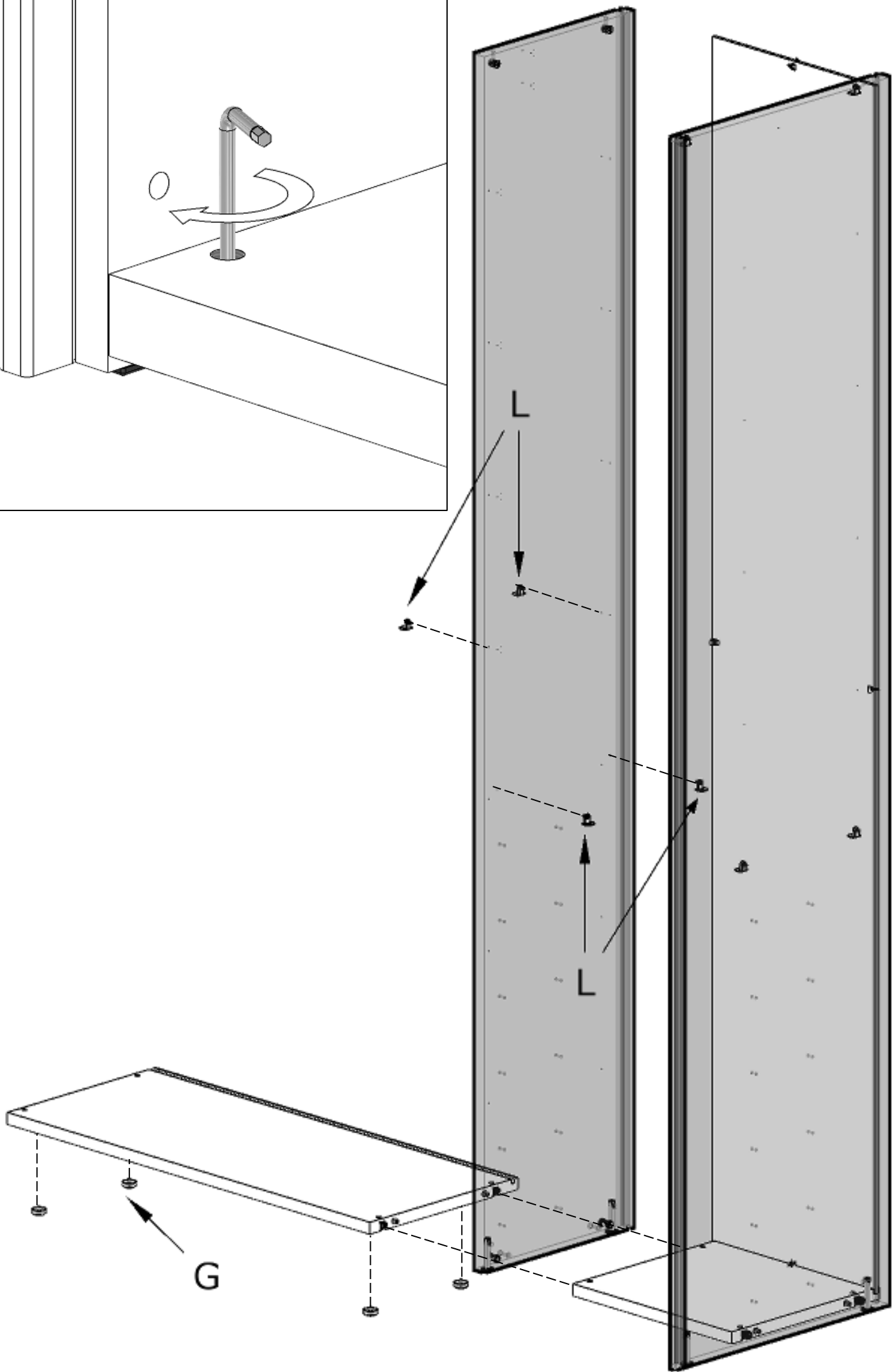
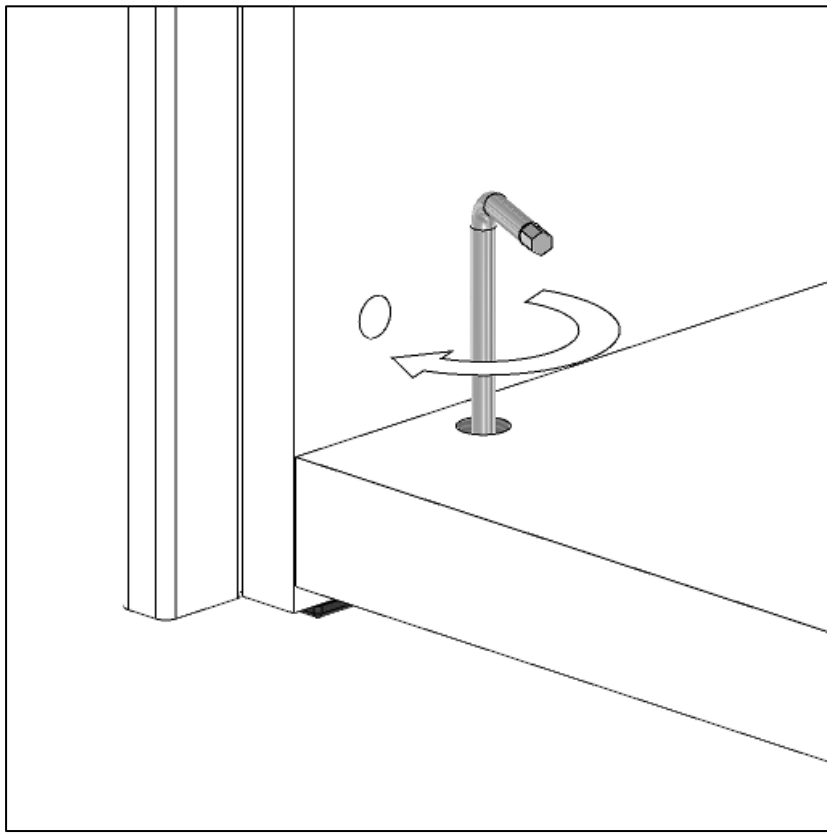

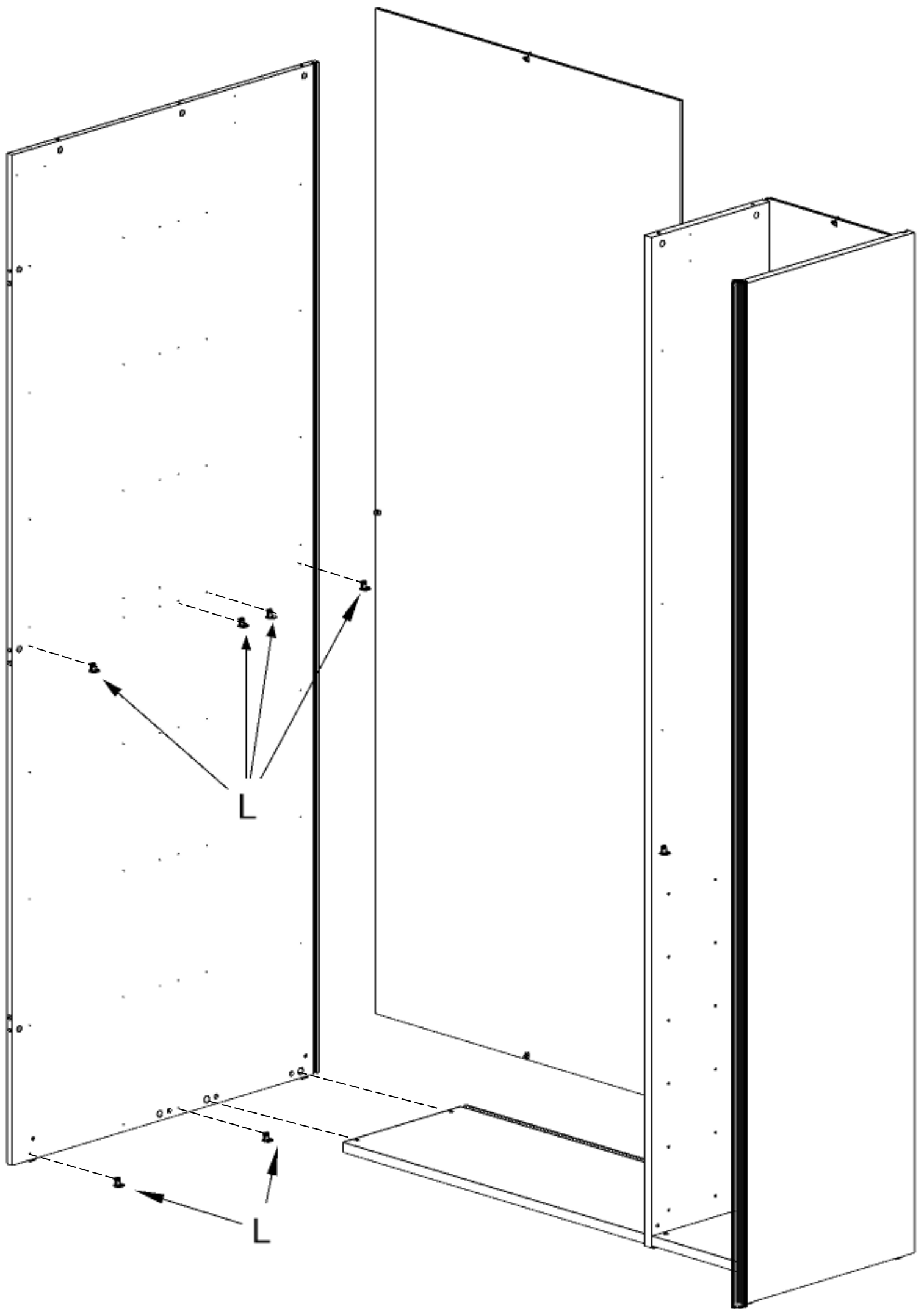

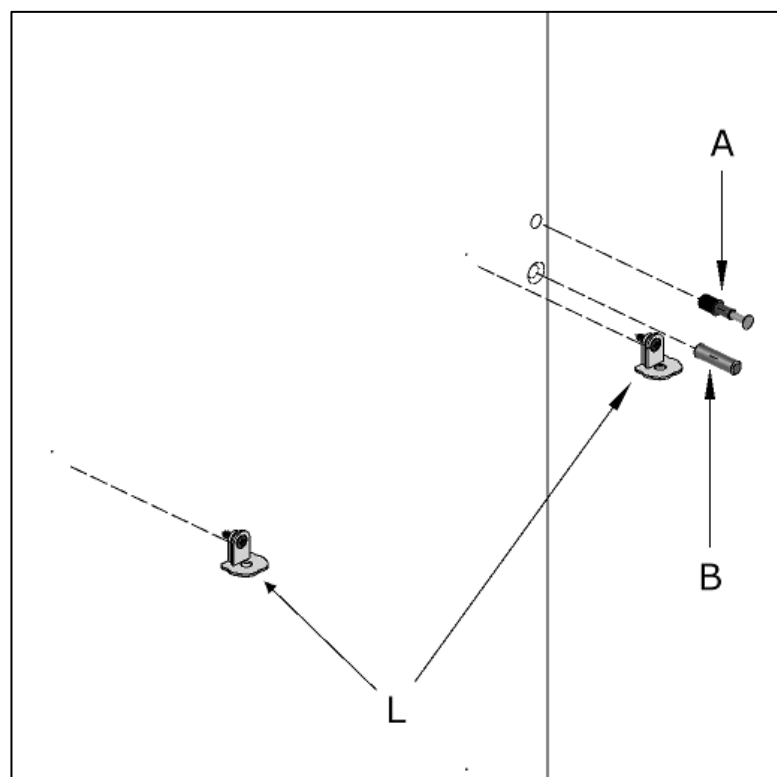
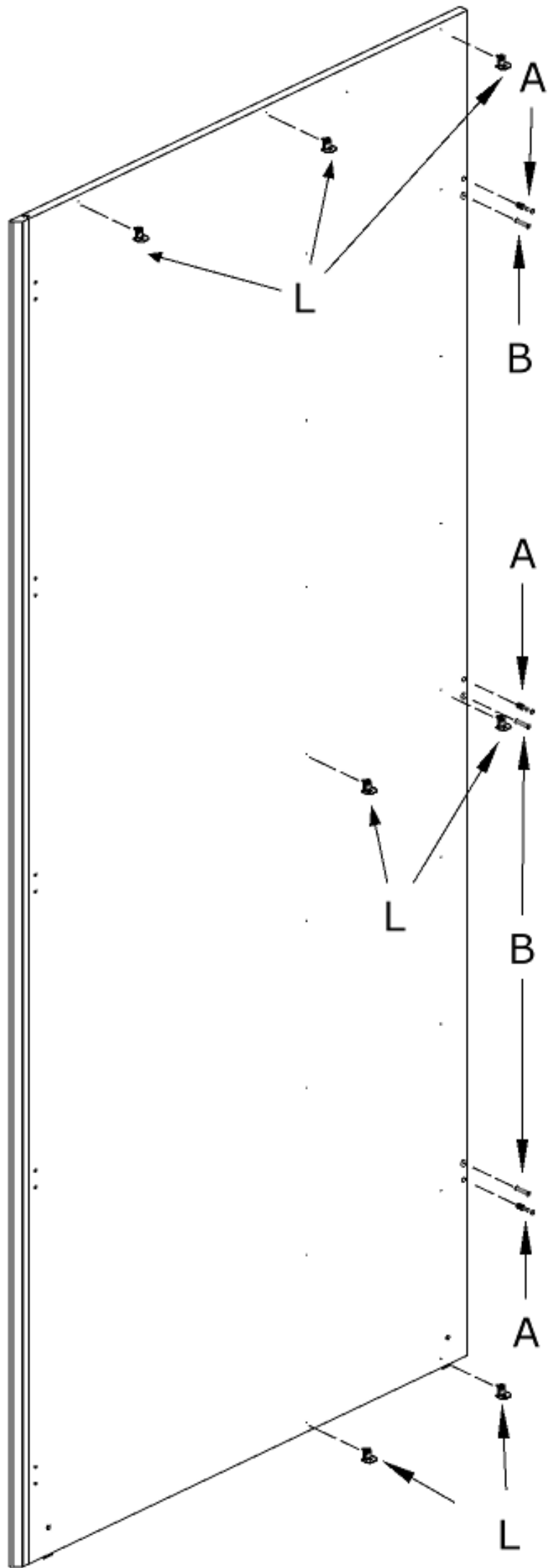

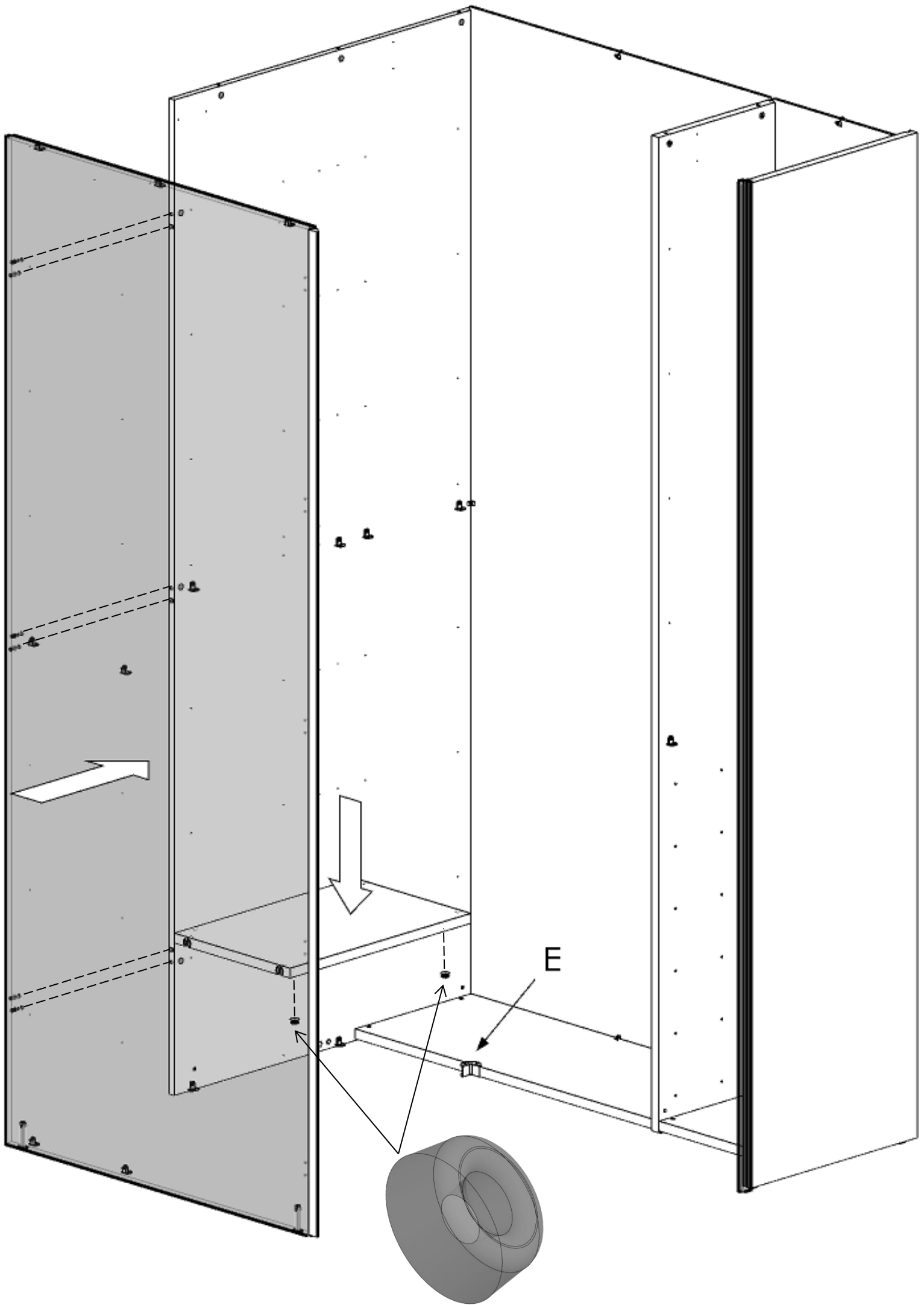

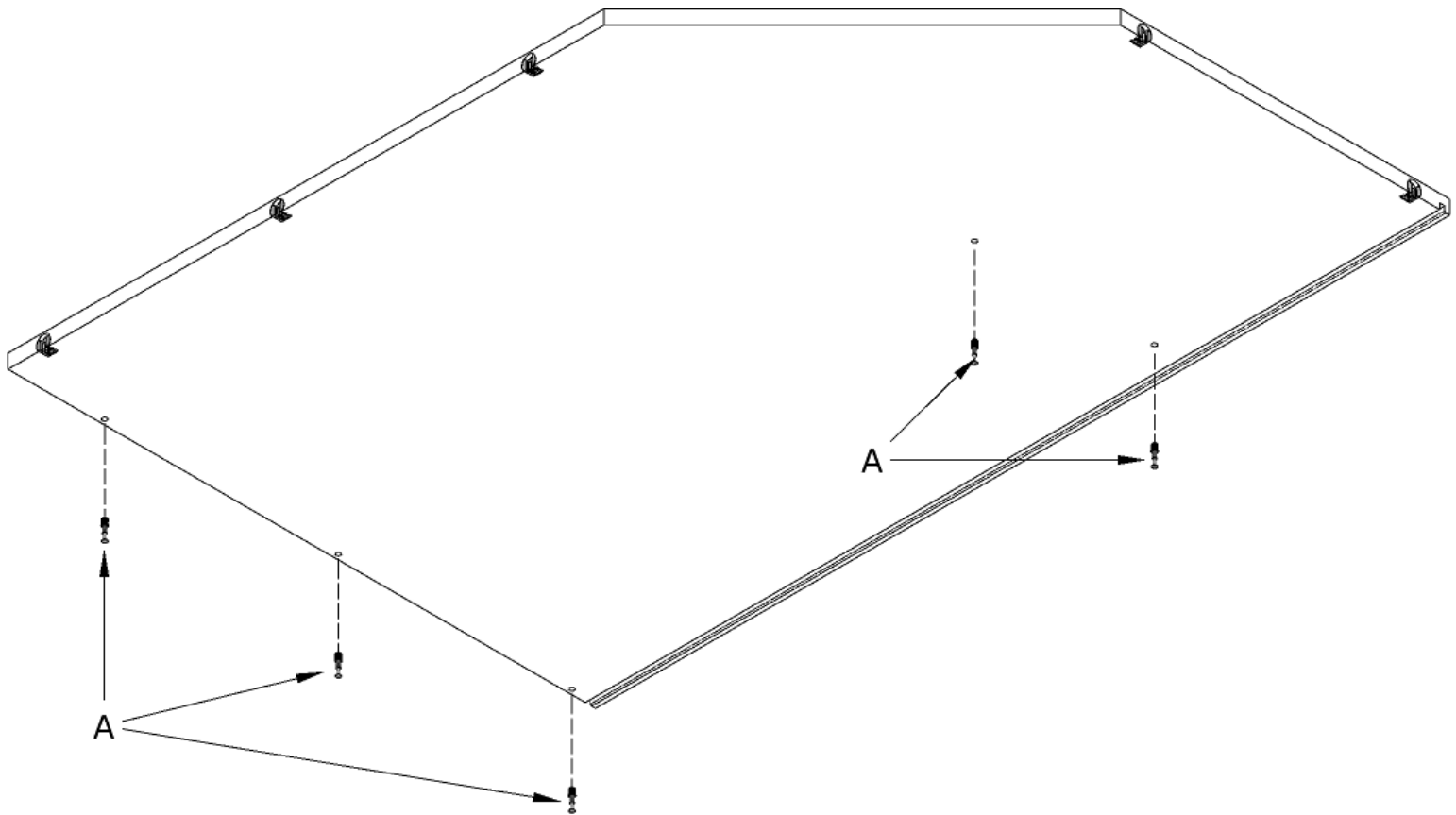
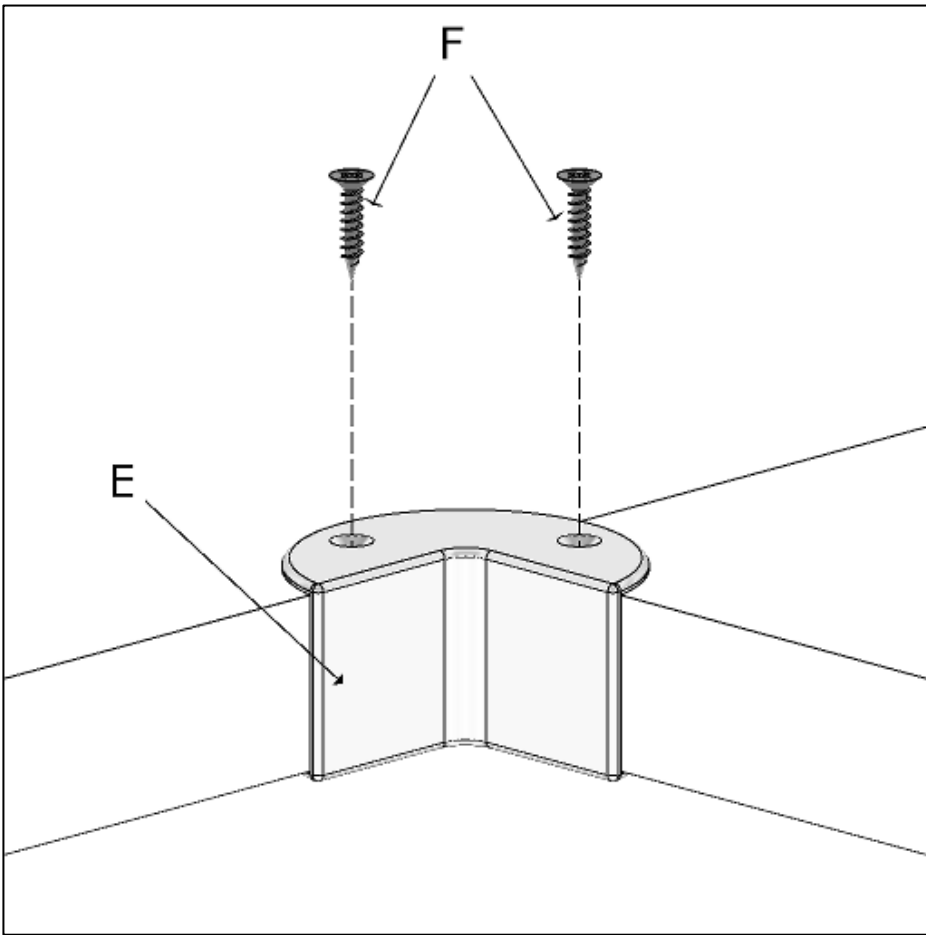

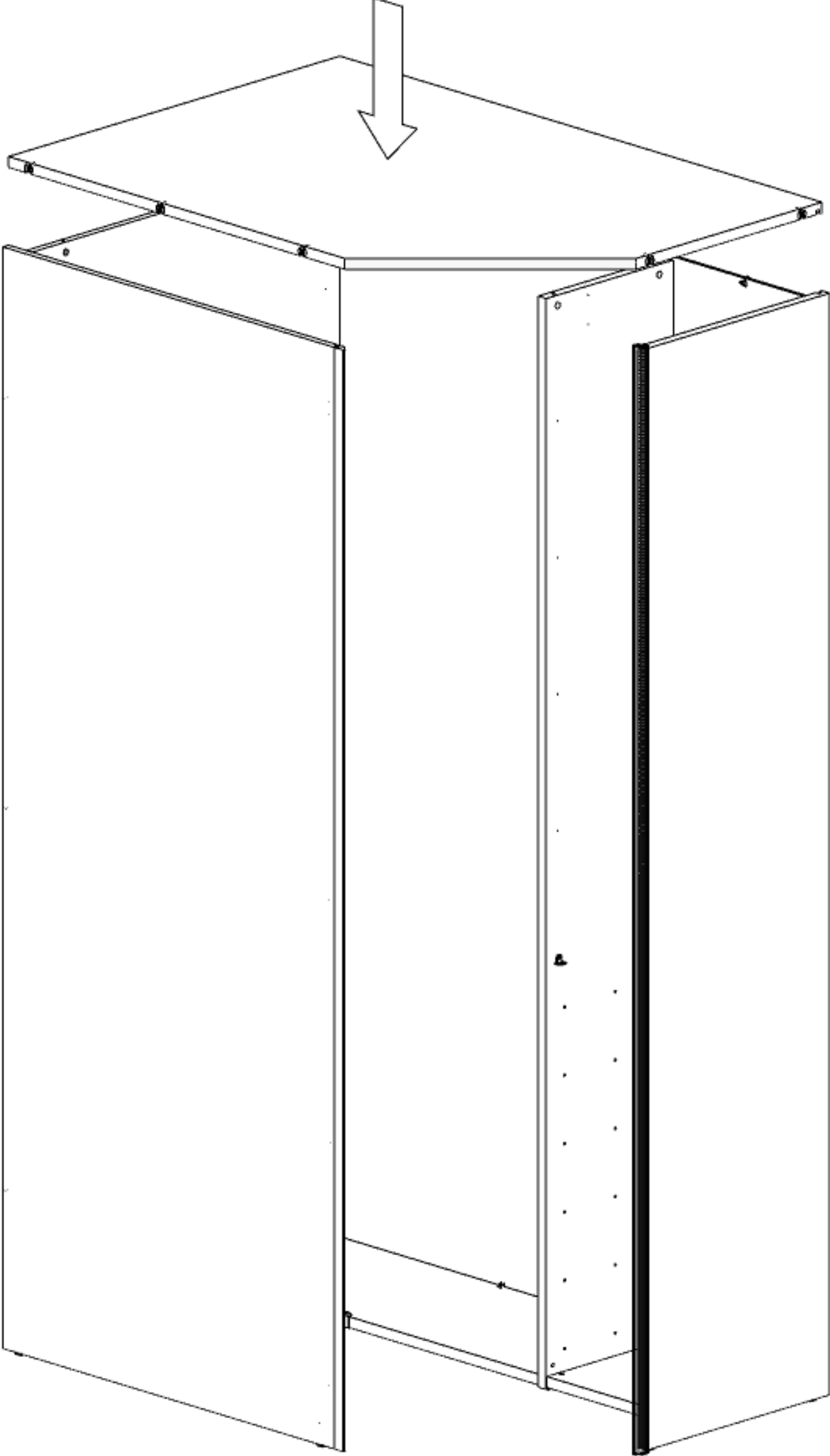

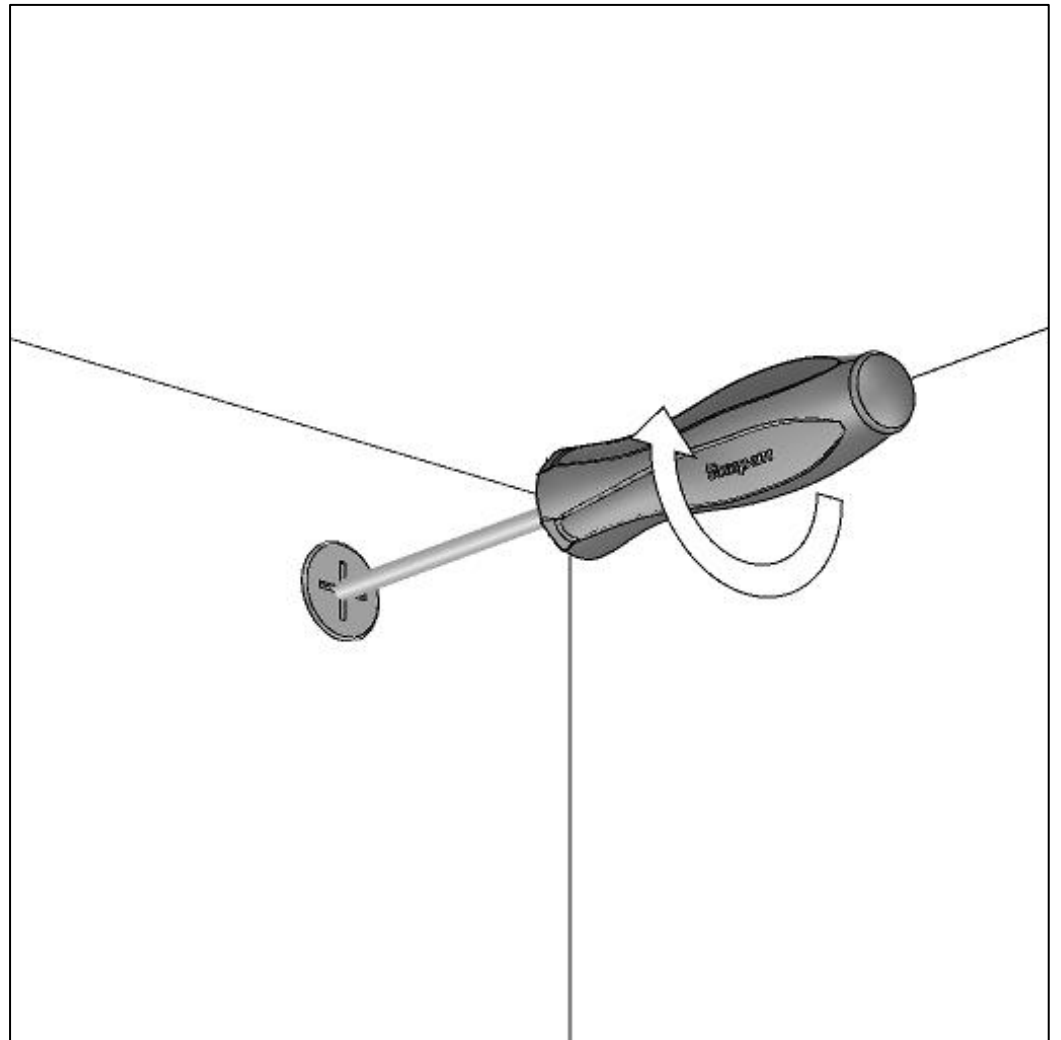
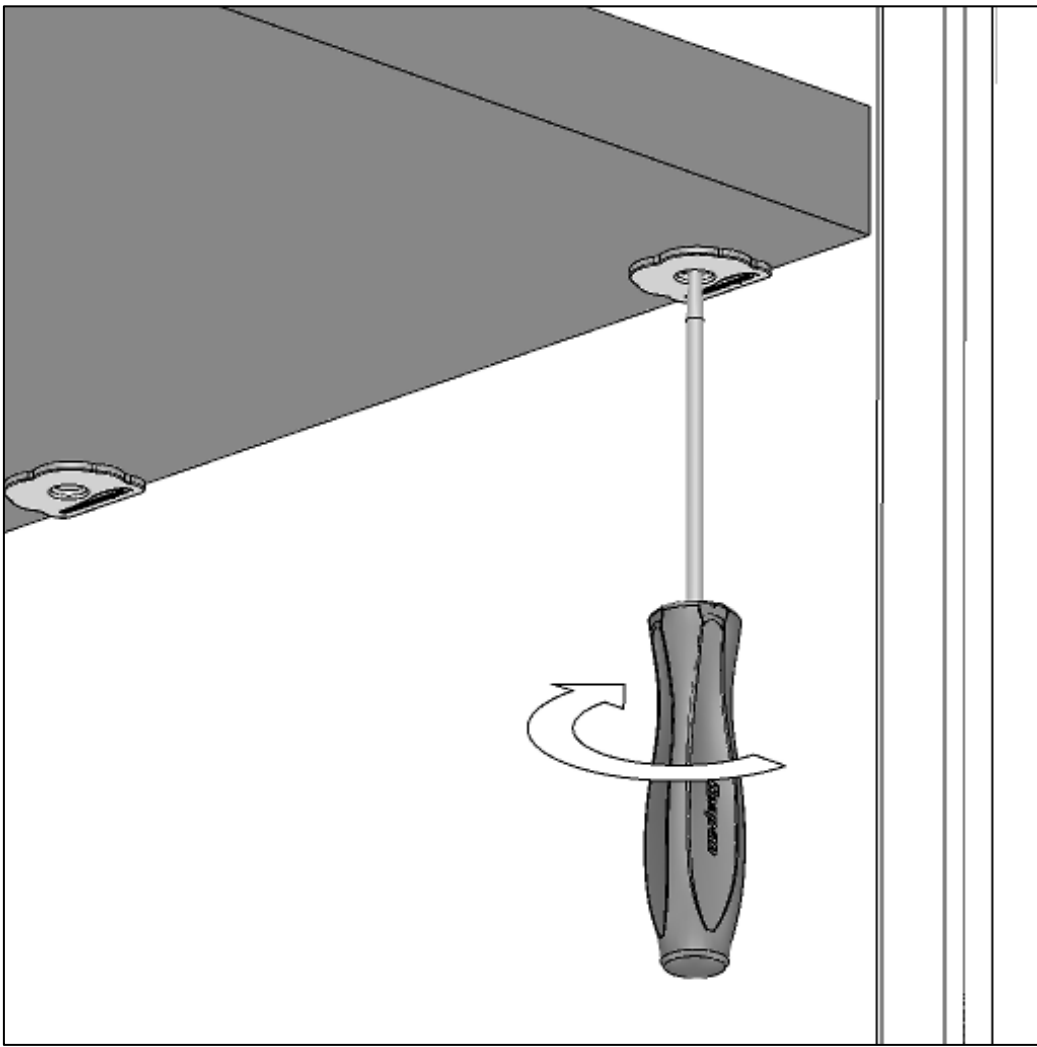

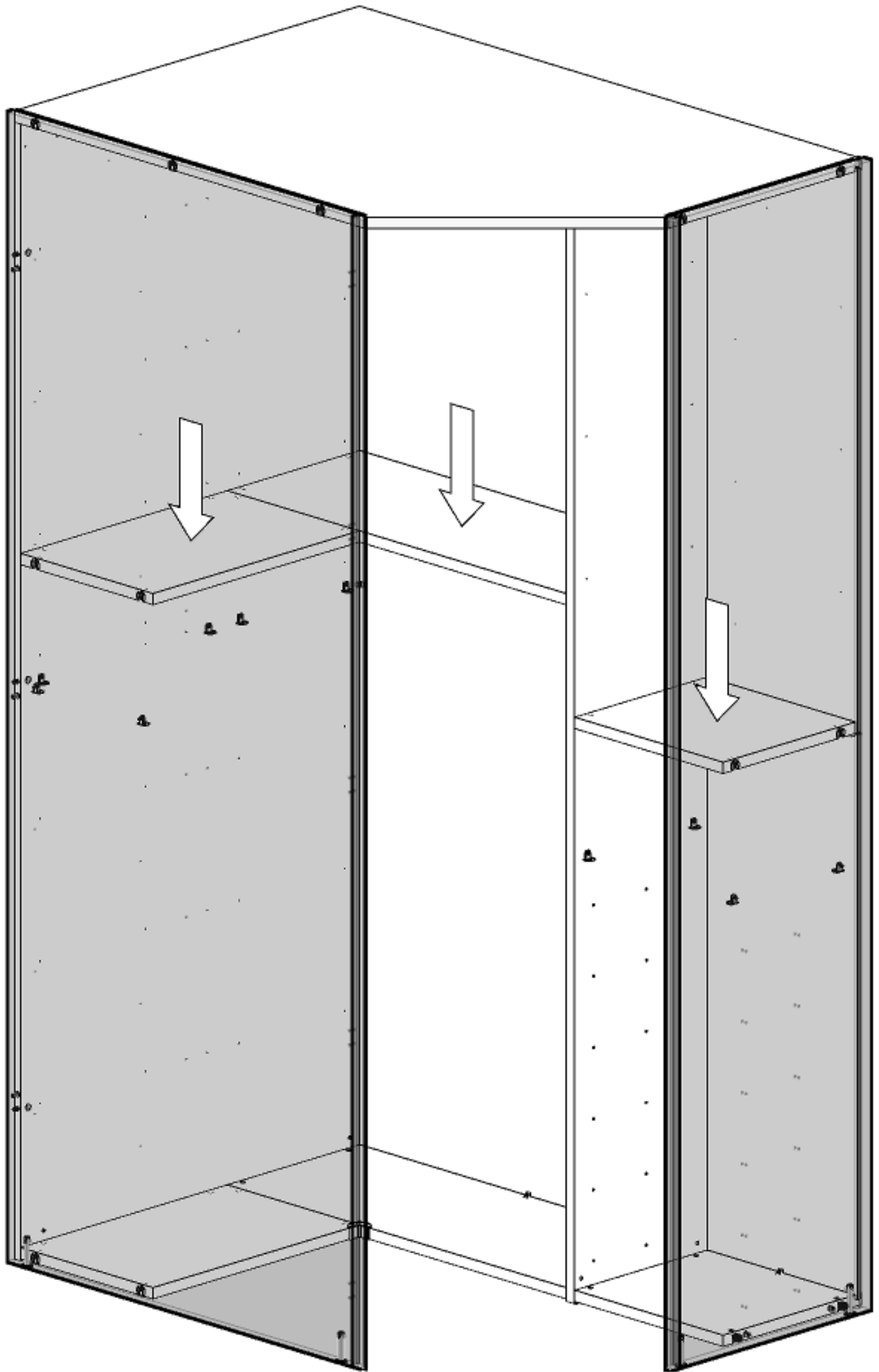

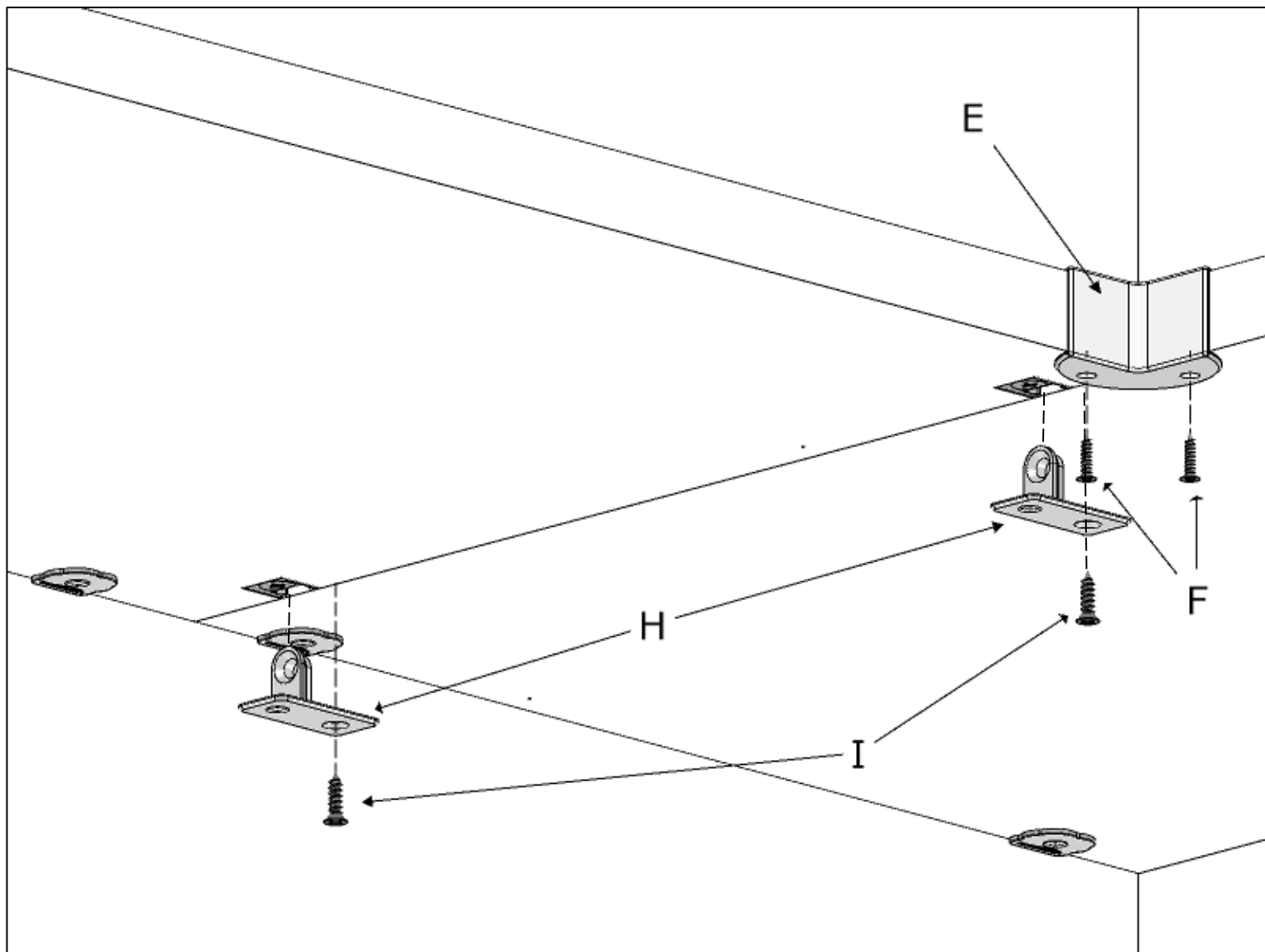
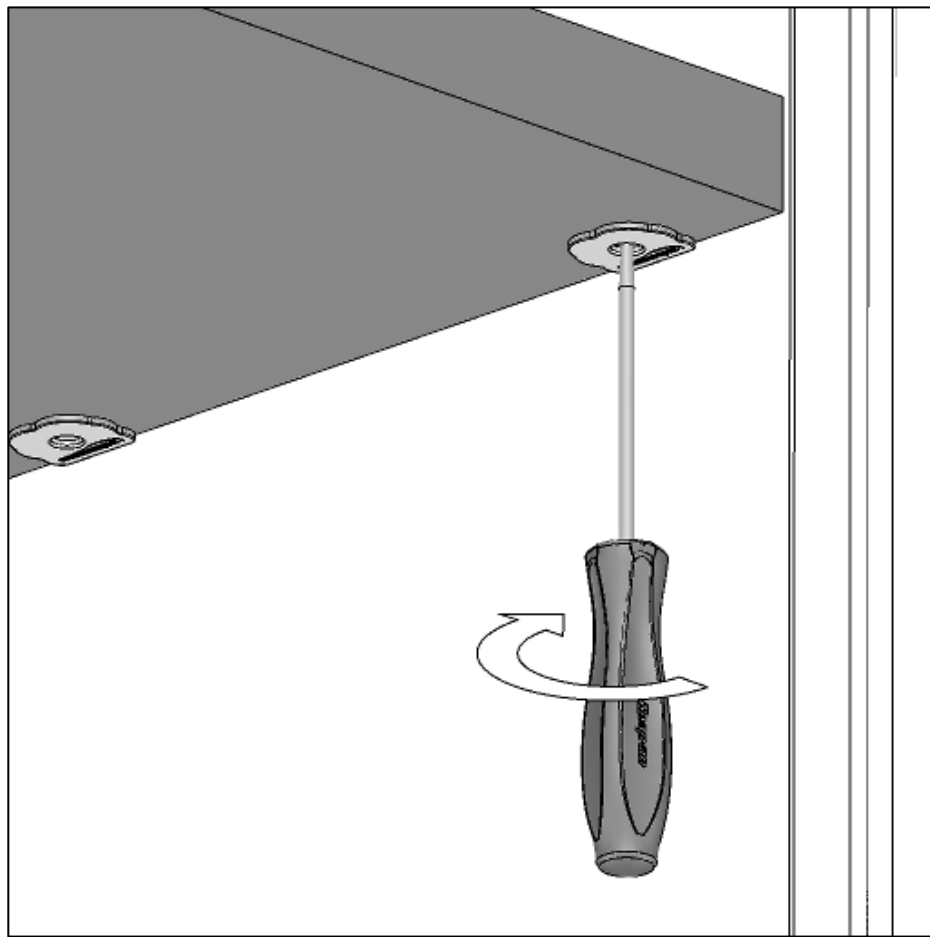

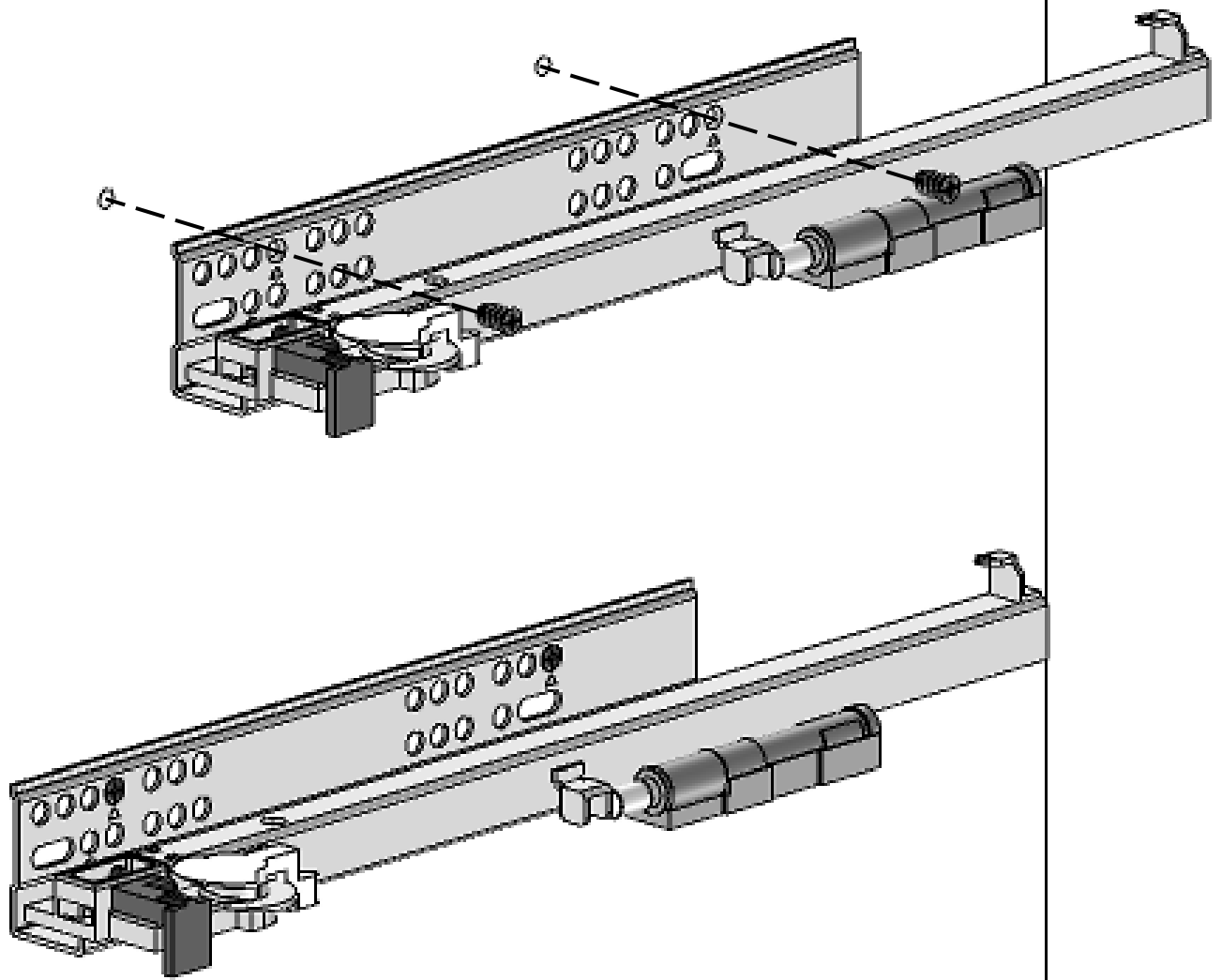

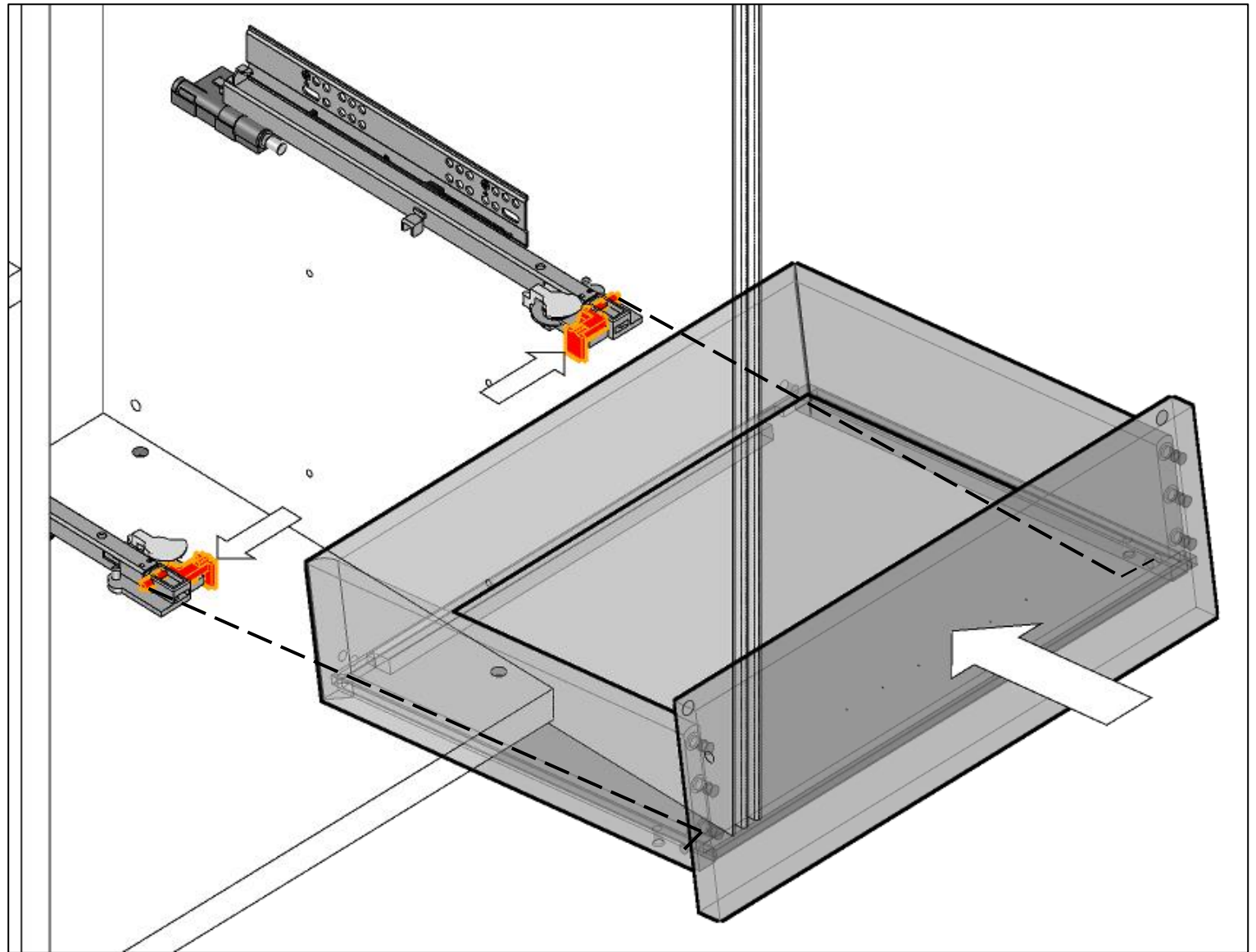

Posizione iniziale della leva per la regolazione verticale.

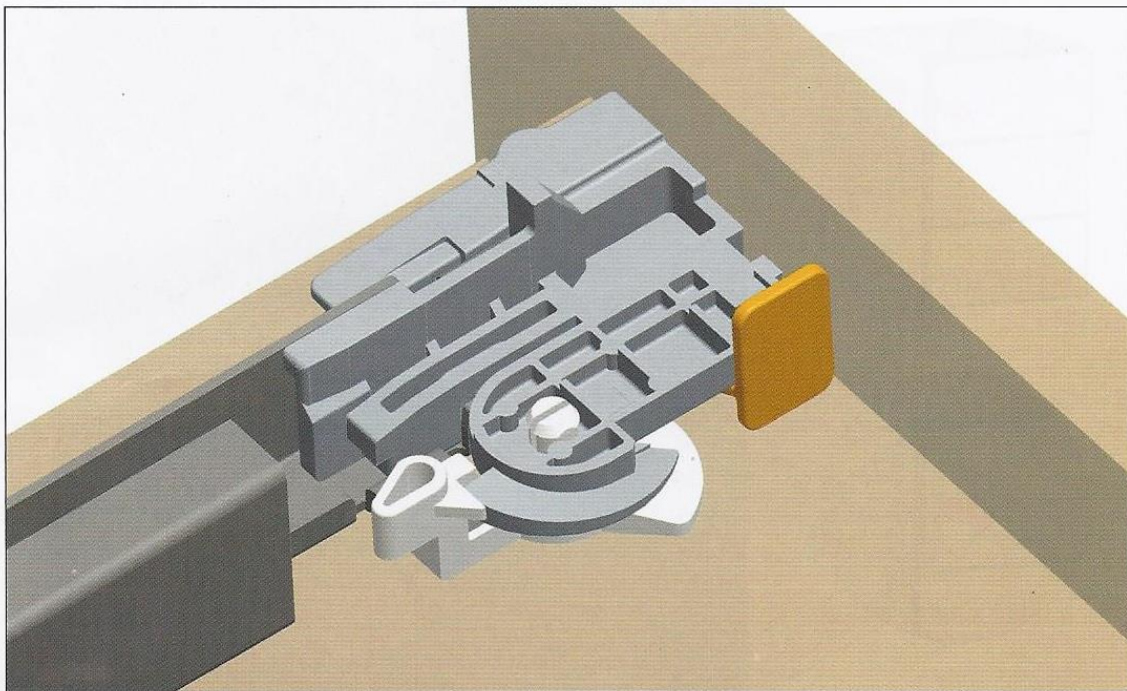
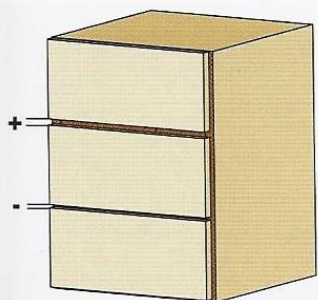

Ruotare la leva verso il frontale del cassetto per ottenere la regolazione verticale.

Questa operazione si effettua senza l'utilizzo di alcun utensile.

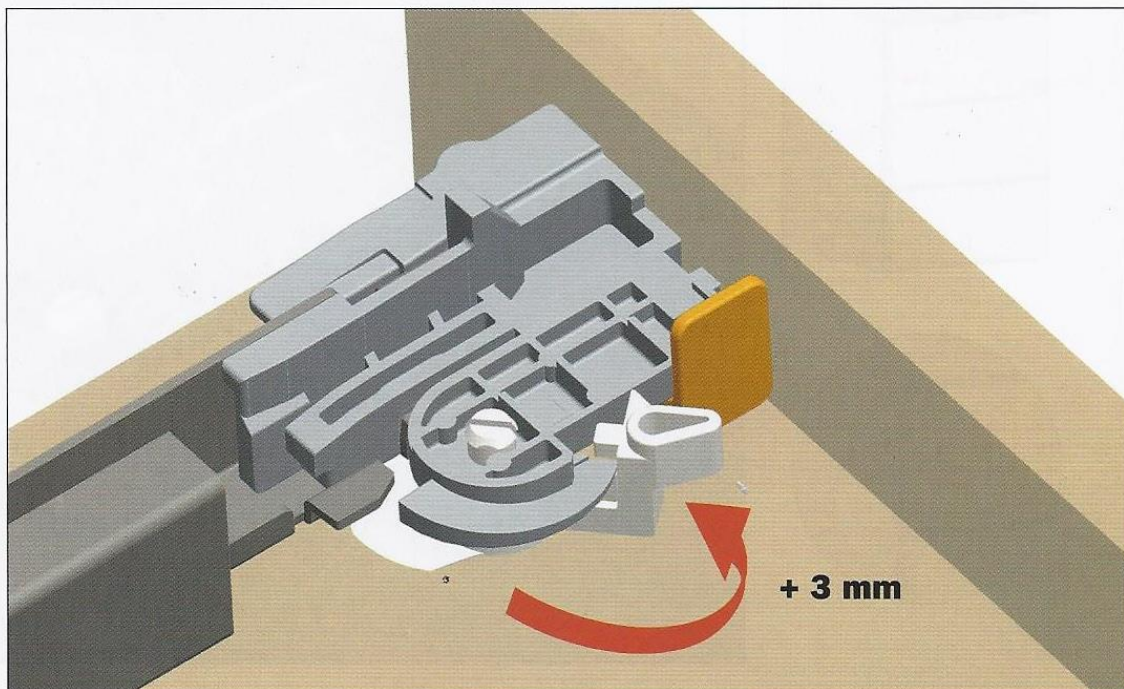
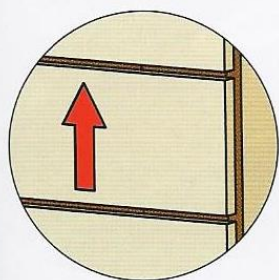
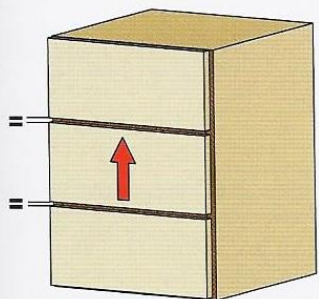

Ruotare la rotella nera verso il frontale del cassetto per aumentare l'aria tra il frontale e il fianco.

Questa operazione si effettua senza l'utilizzo di alcun utensile.

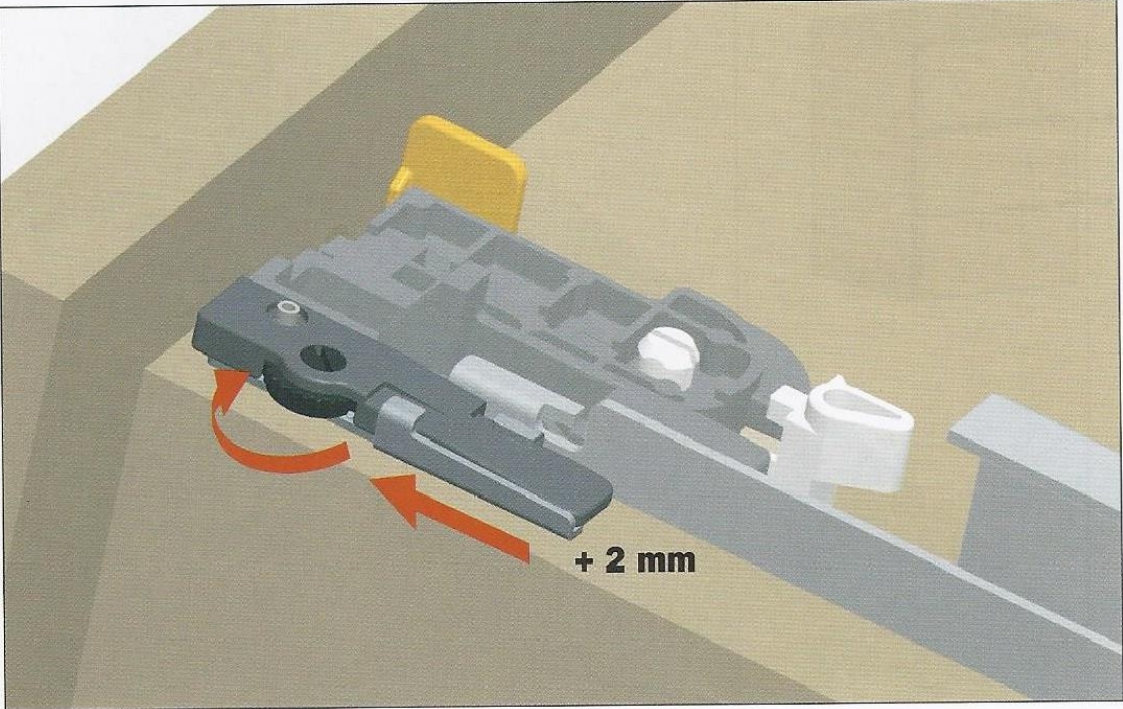
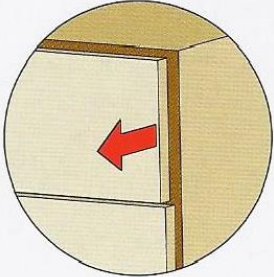
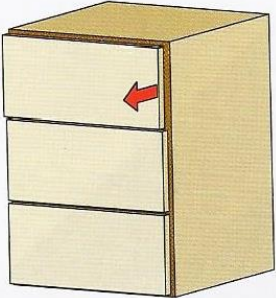

Ruotare la rotella nera verso il retro del cassetto per diminuire l'aria tra il frontale e il fianco.

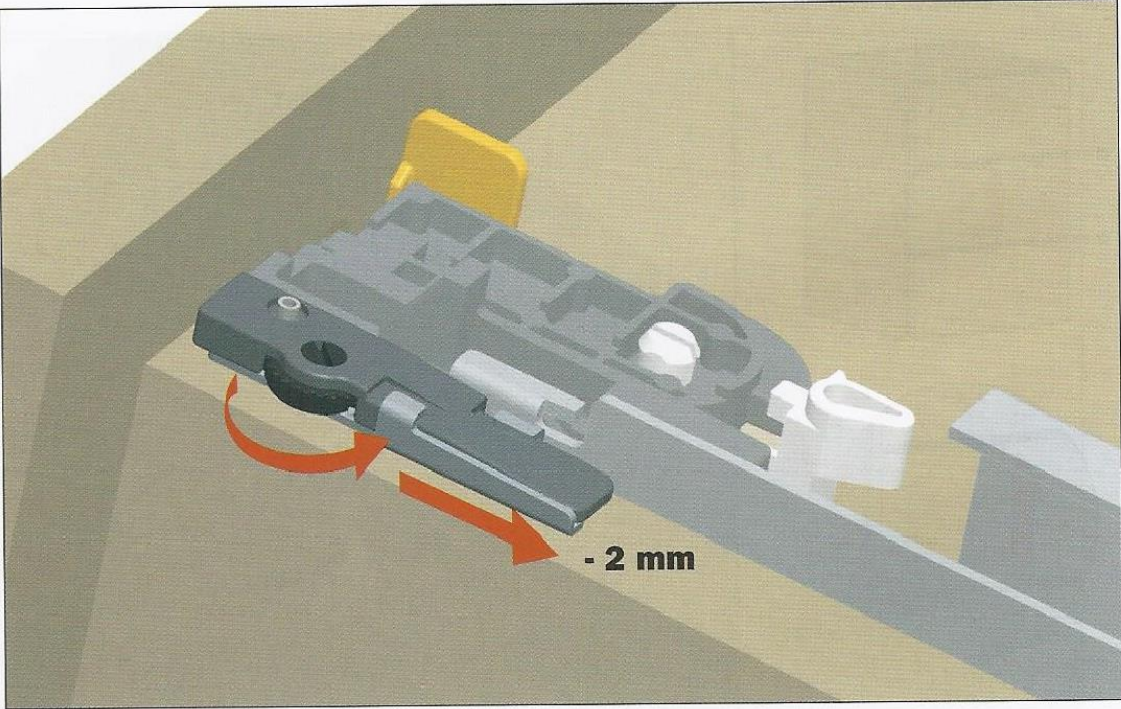
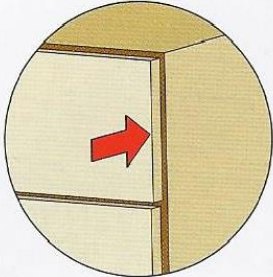
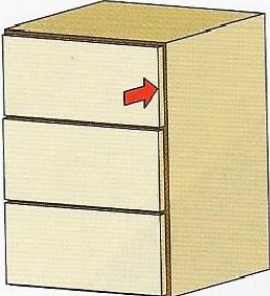

Questa operazione si effettua senza l'utilizzo di alcun utensile.

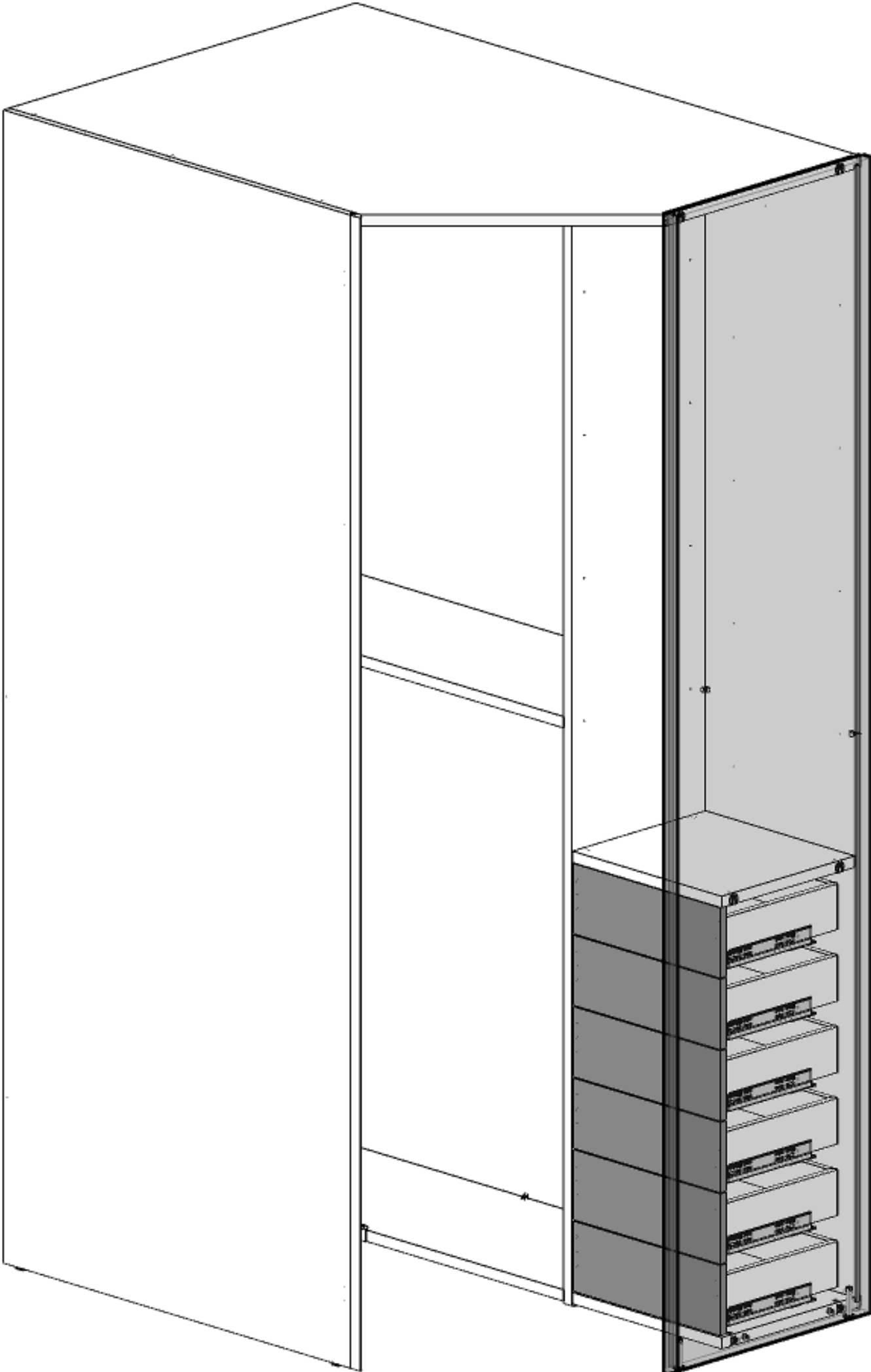

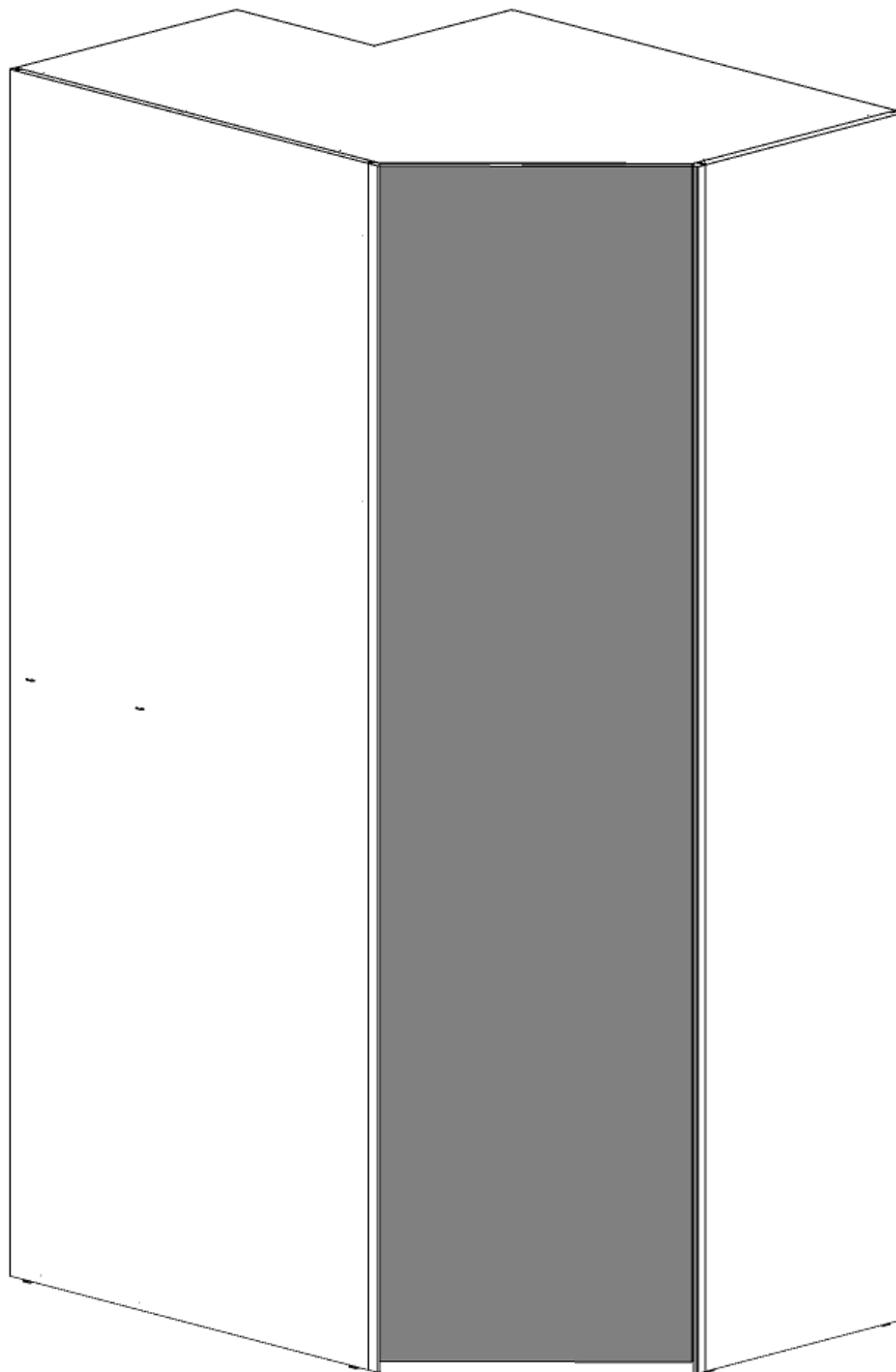



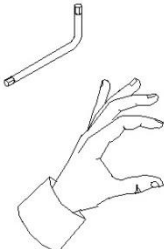

080005838 - SFR_Sac.Fr.Strt.Wide Cut

20000666	A		n°6	
20000996	B		n°4	
200002161	C		n°1	

080005145 - SFR_Sac.Fr.Pied.Base.Mod.Std

200001980	G		n°4	
-----------	---	---	------------	---

REGGIRIPIANO

	L		n°21	
--	---	---	-------------	---



080005145 - SFR_Sac.Fr.Pied.Base.Mod.Std

200001980	G		n°4	
-----------	---	---	------------	---

080005145 - SFR_Sac.Fr.Pied.Base.Mod.Std

200001980	G		n°4	
-----------	---	---	------------	---

080005072 - SFR_Sac.Fr.Batt.Ante Alul.Cab

200001381	M		n°1	
200000945	N		n°2	

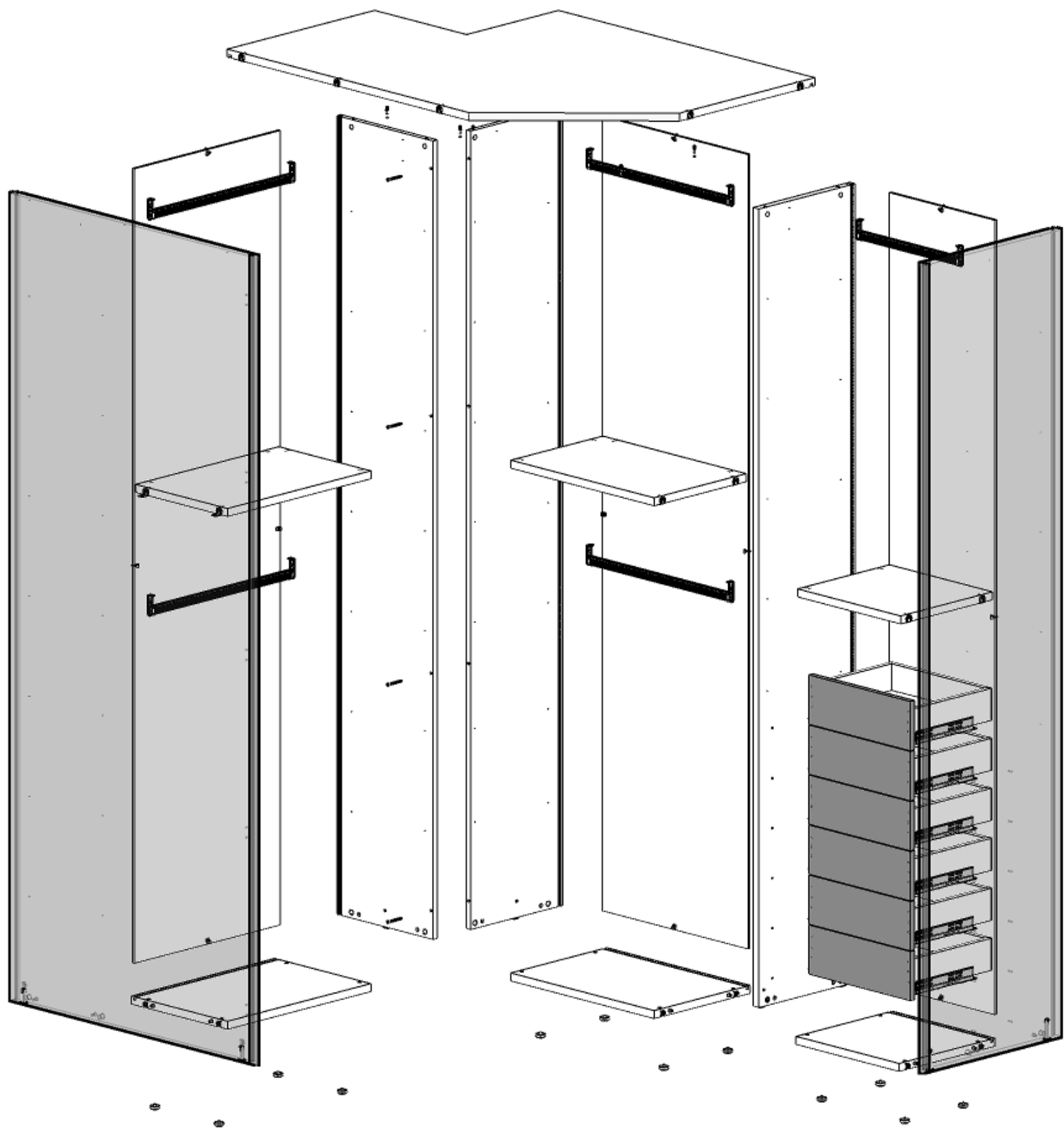

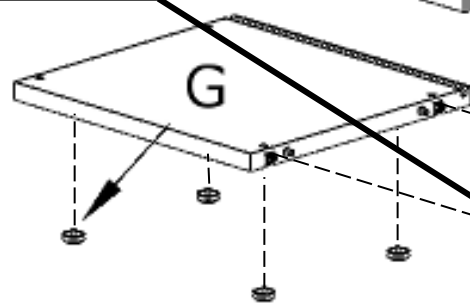
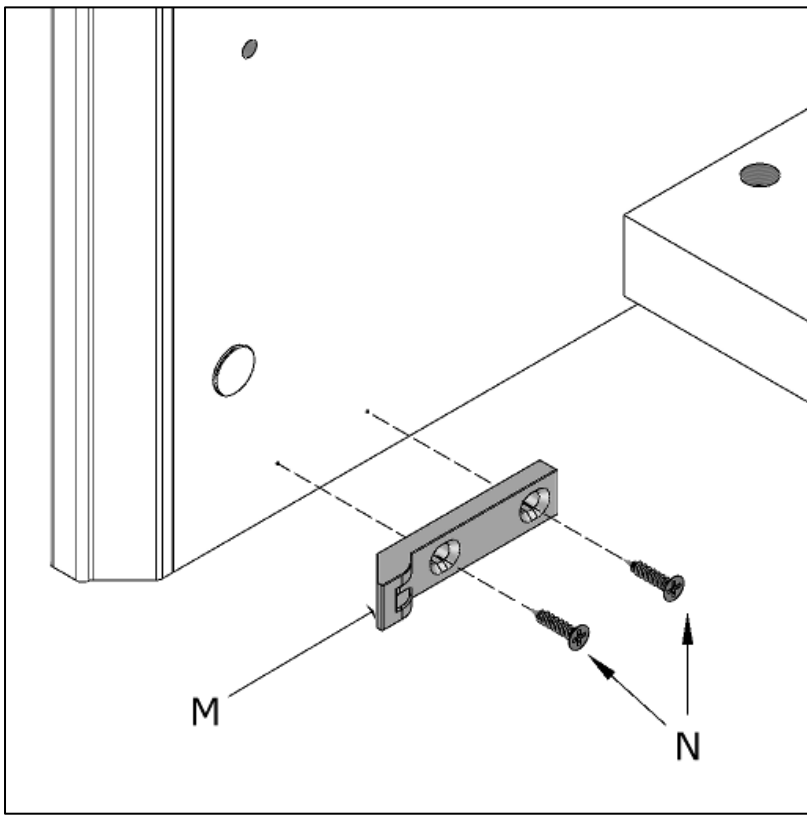
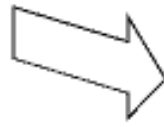
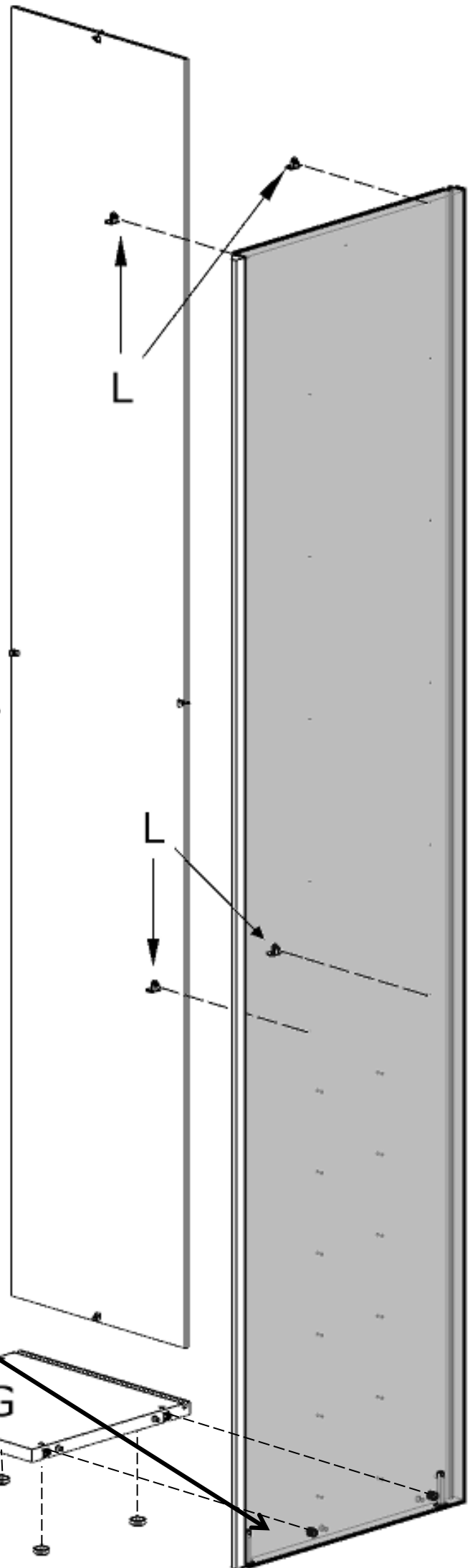
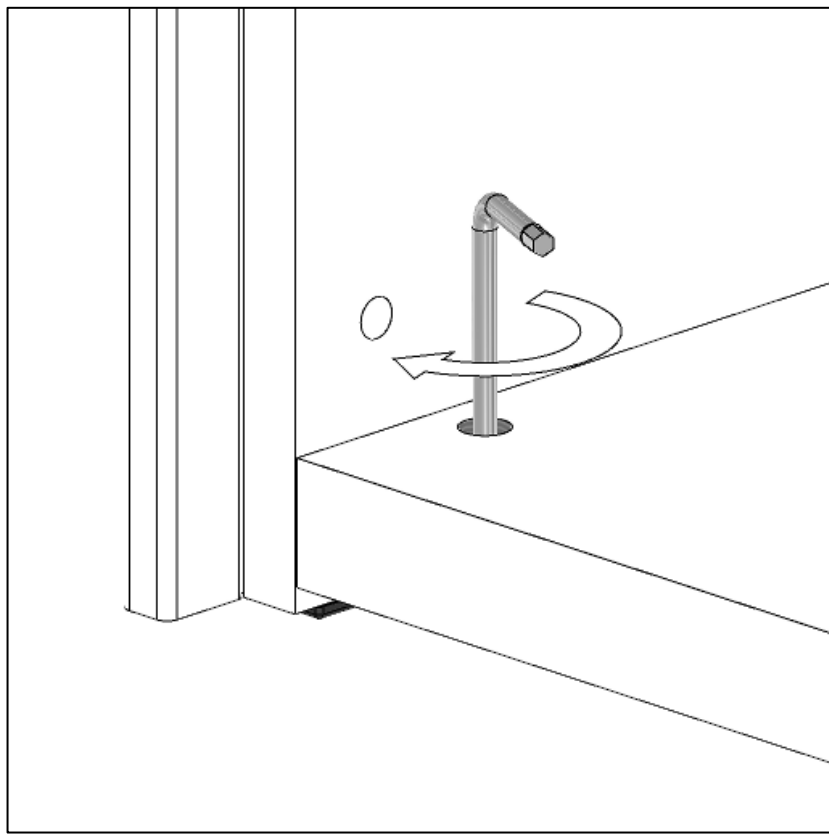

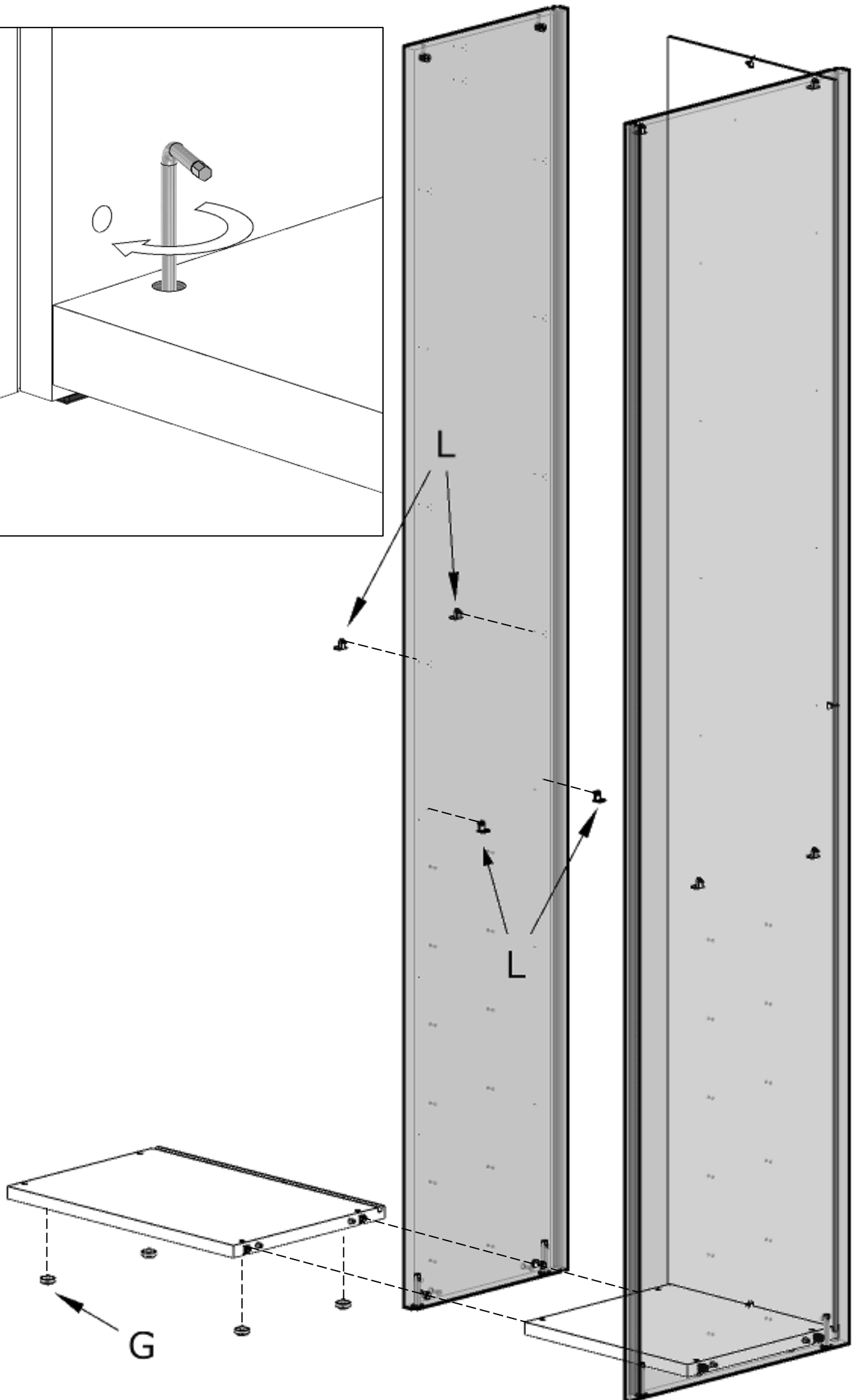
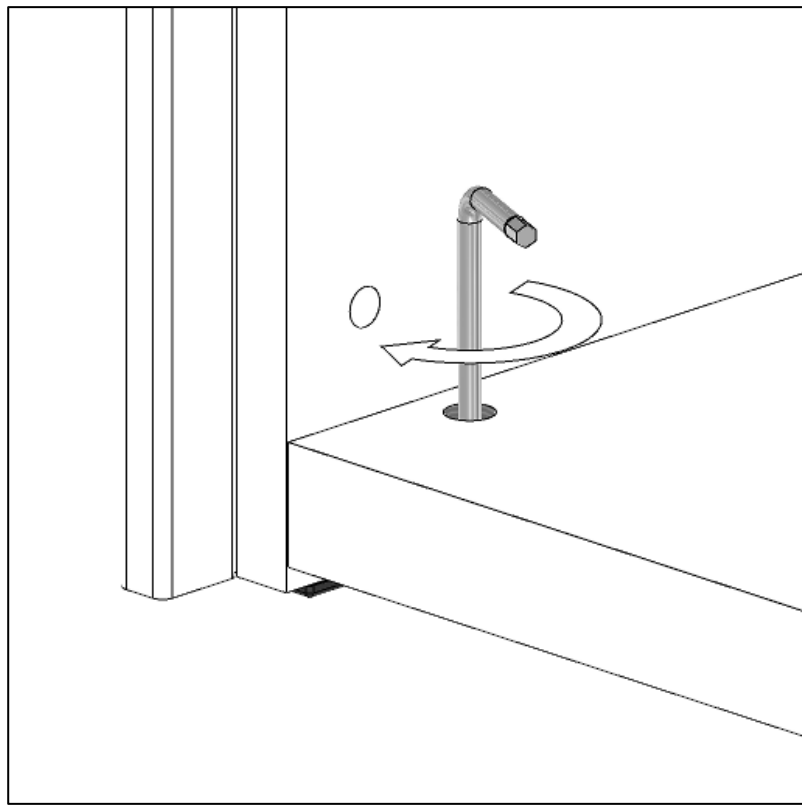

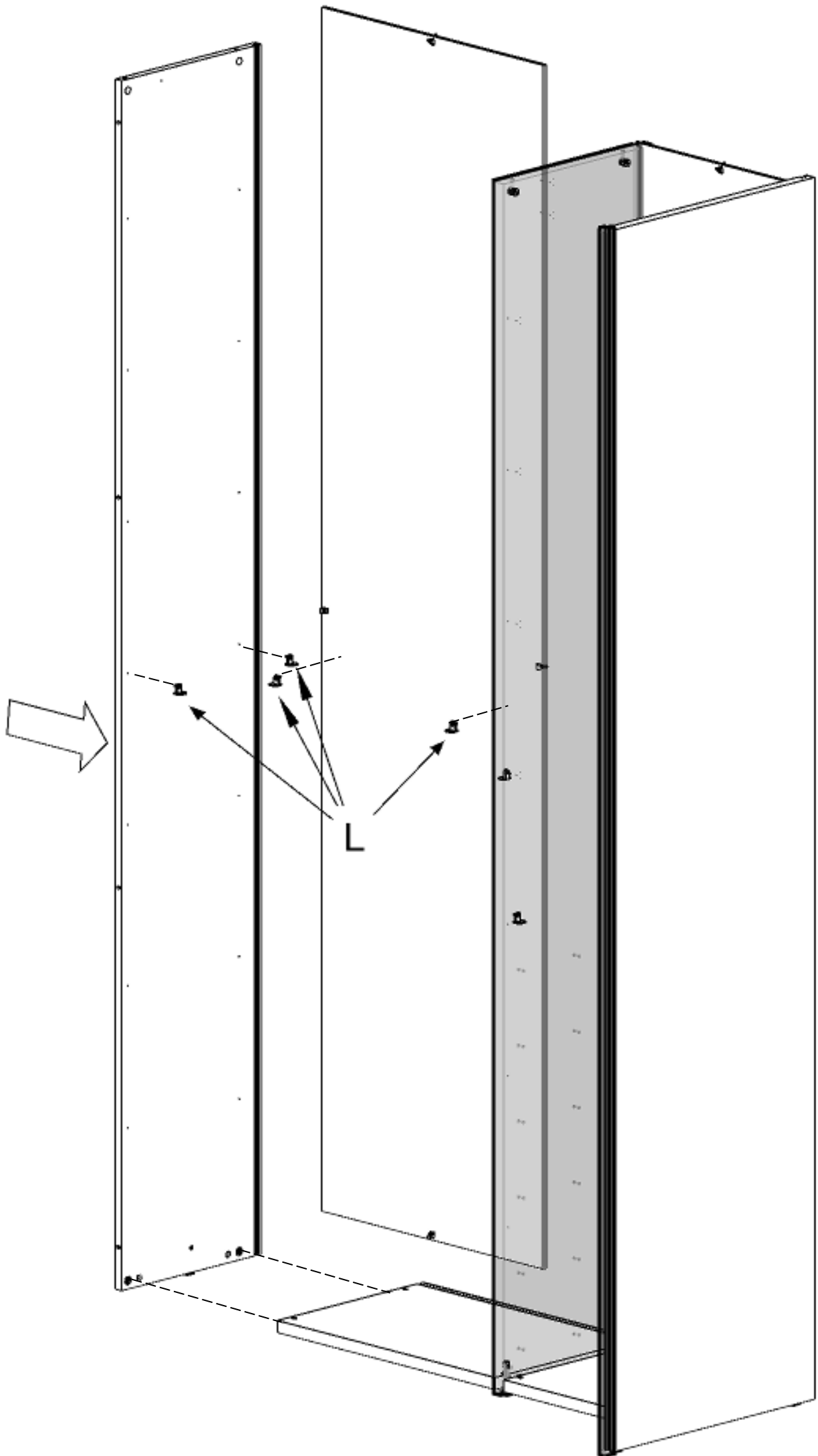

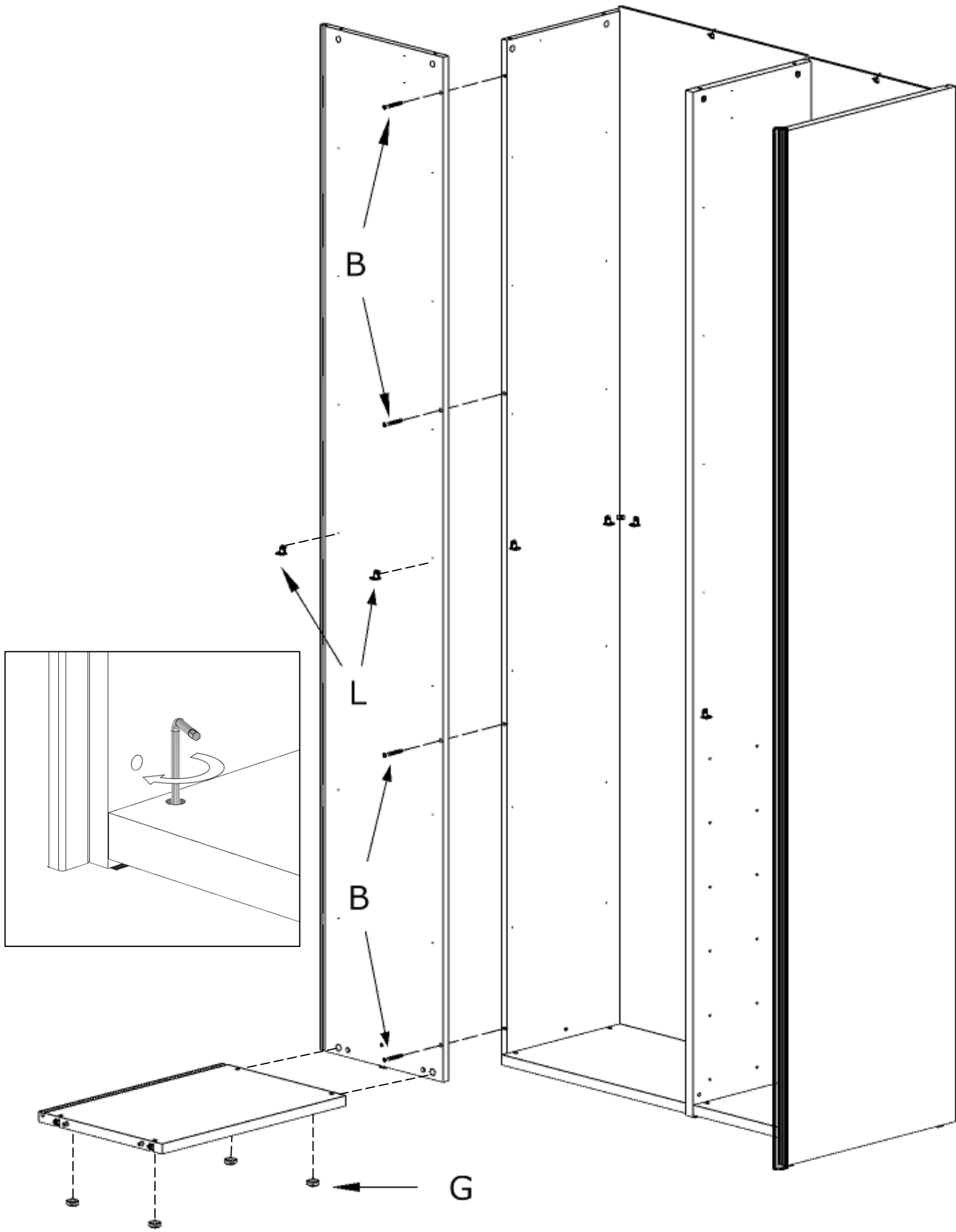

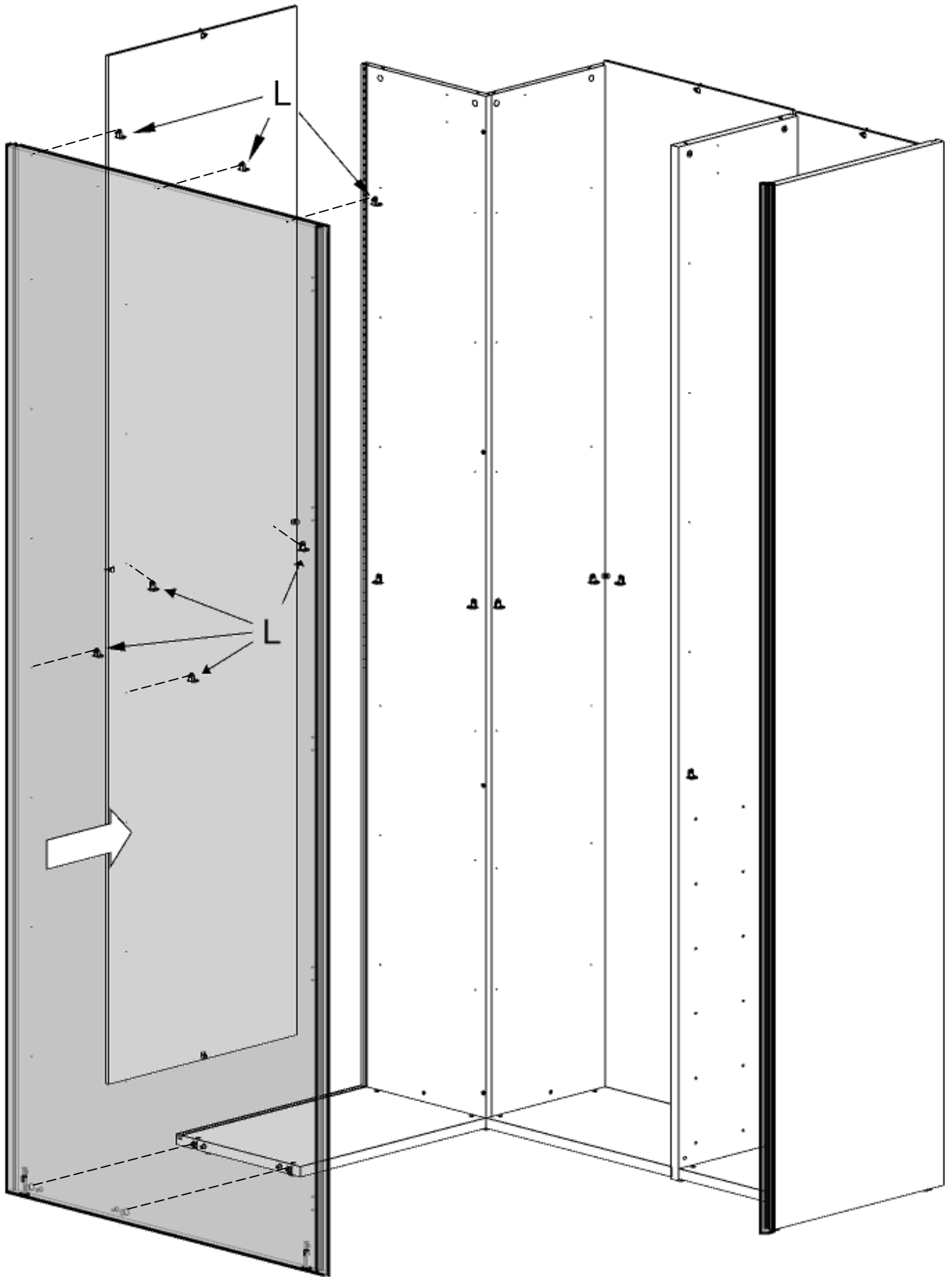

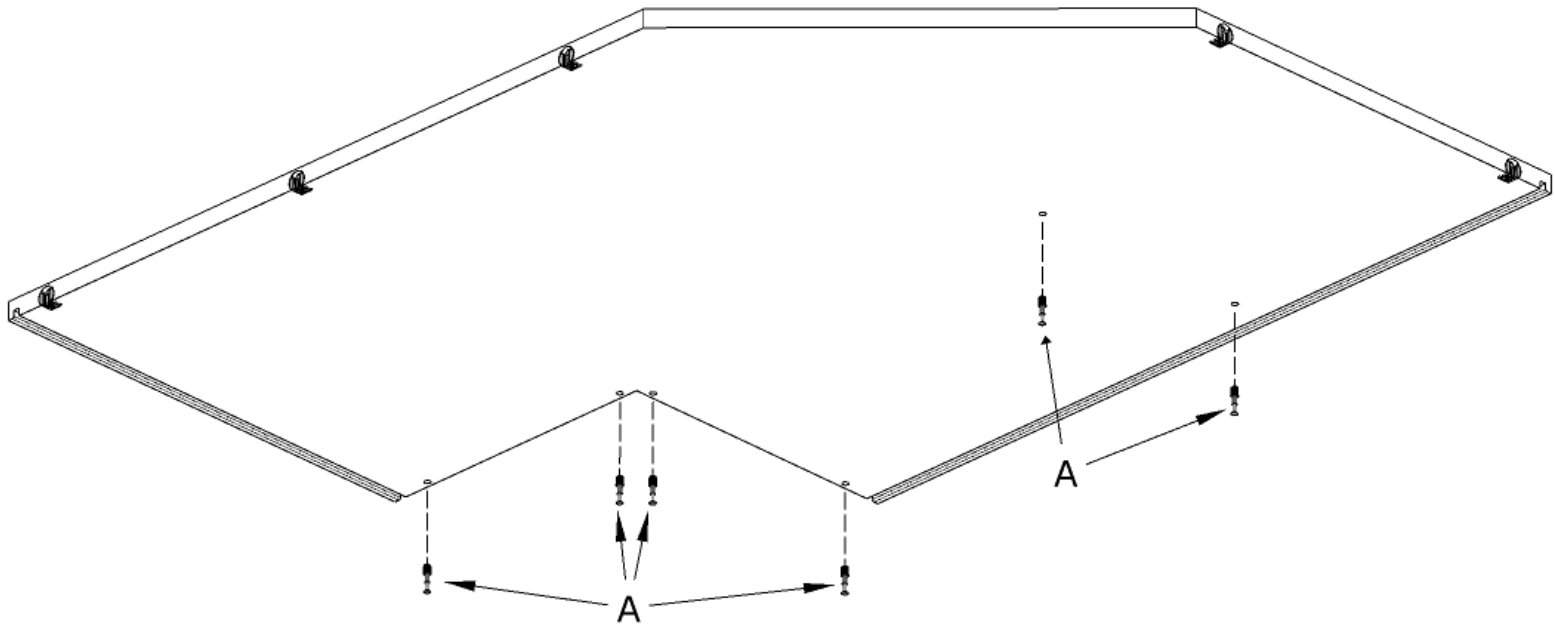
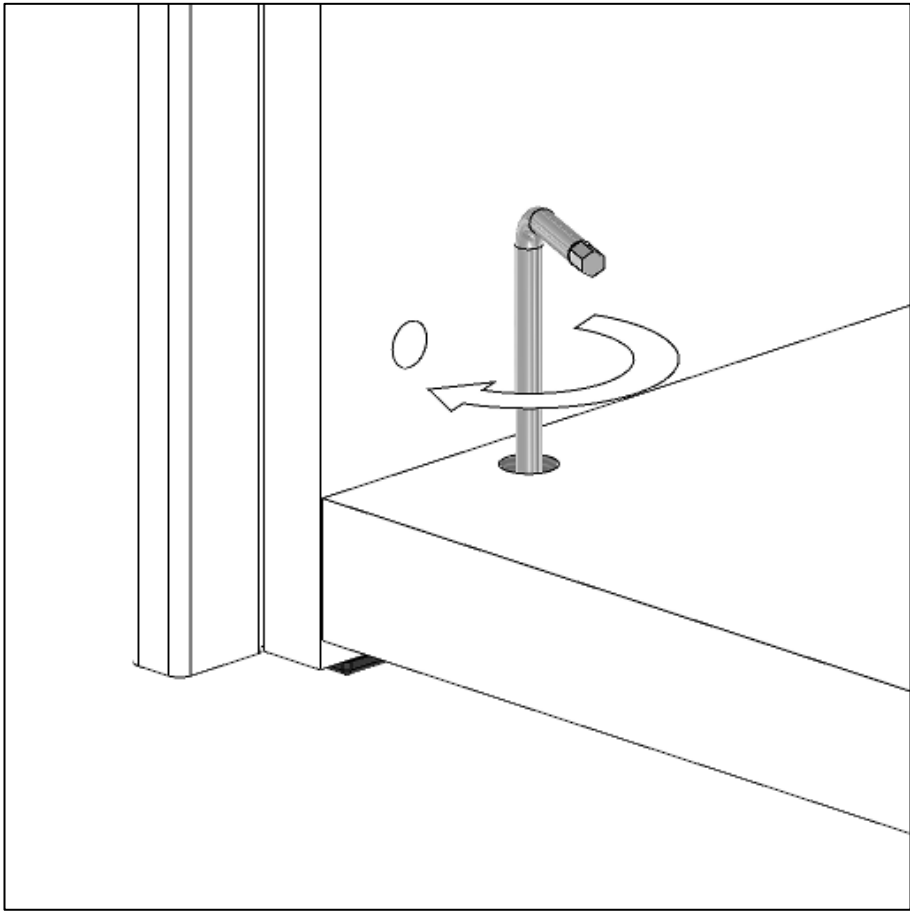

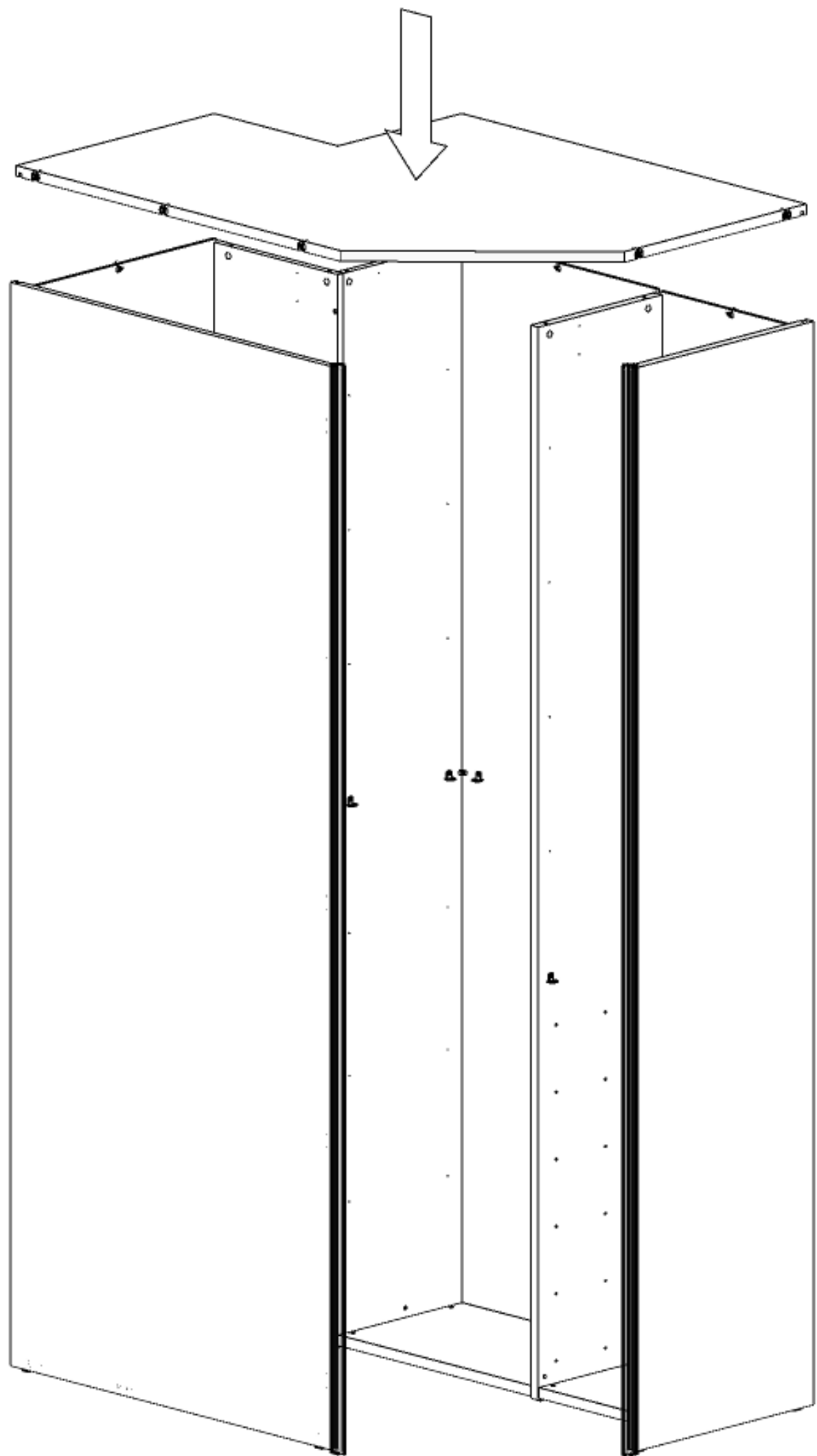

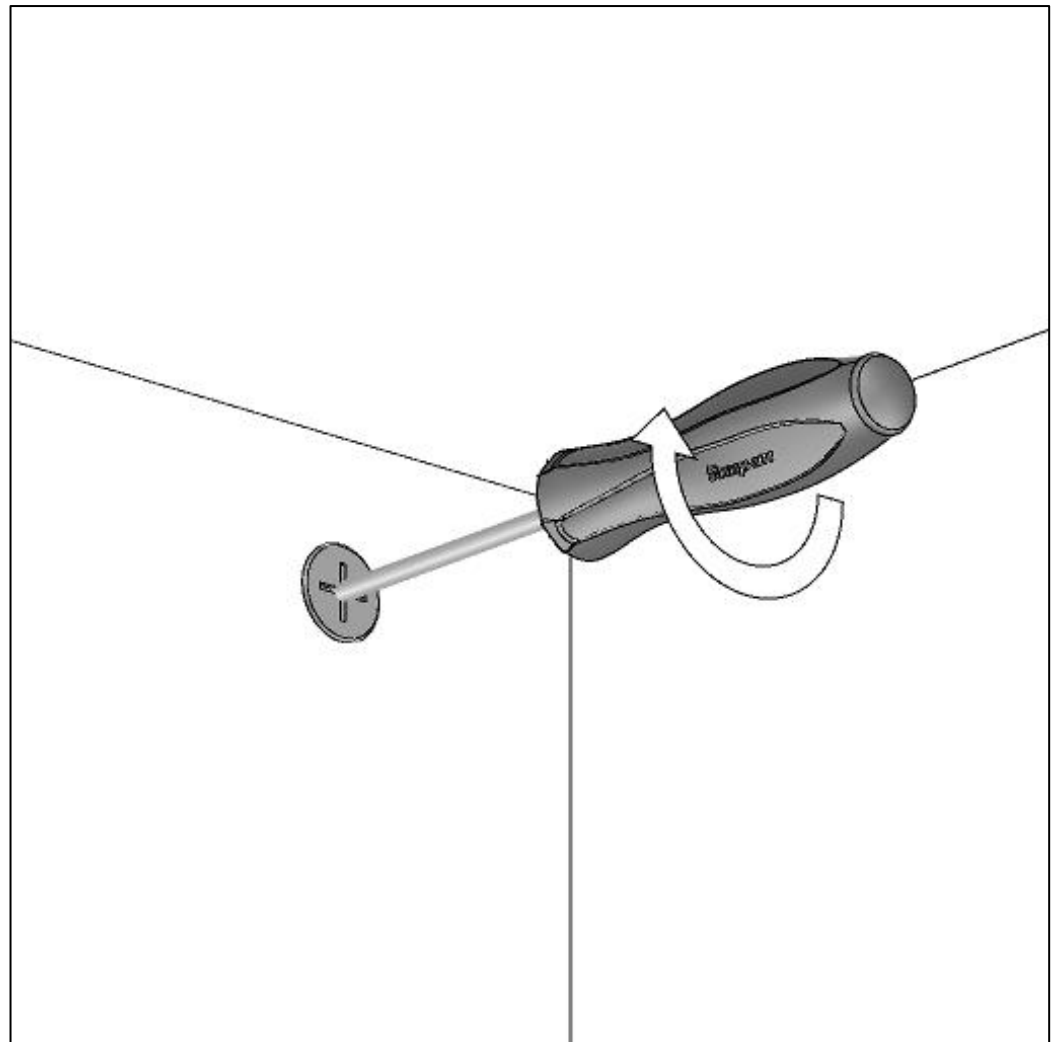
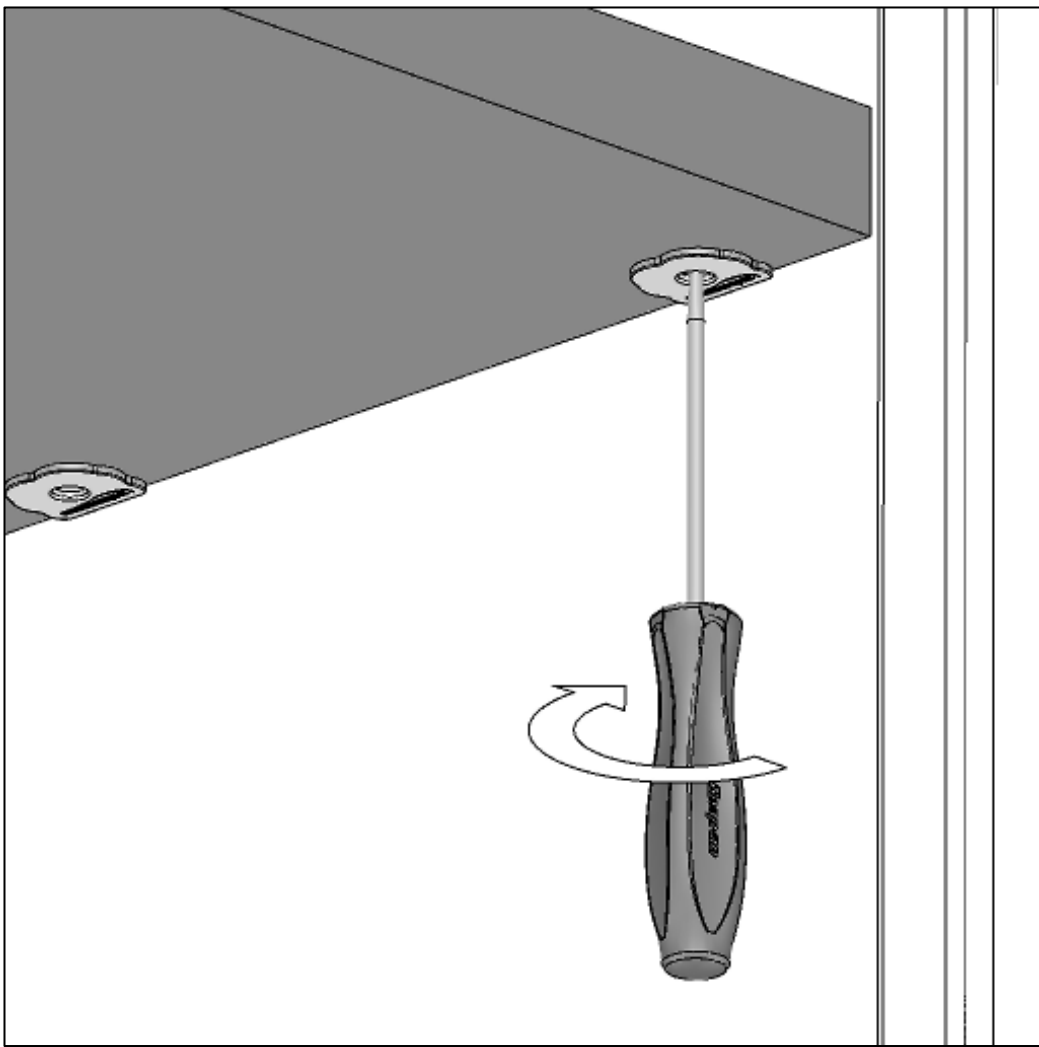

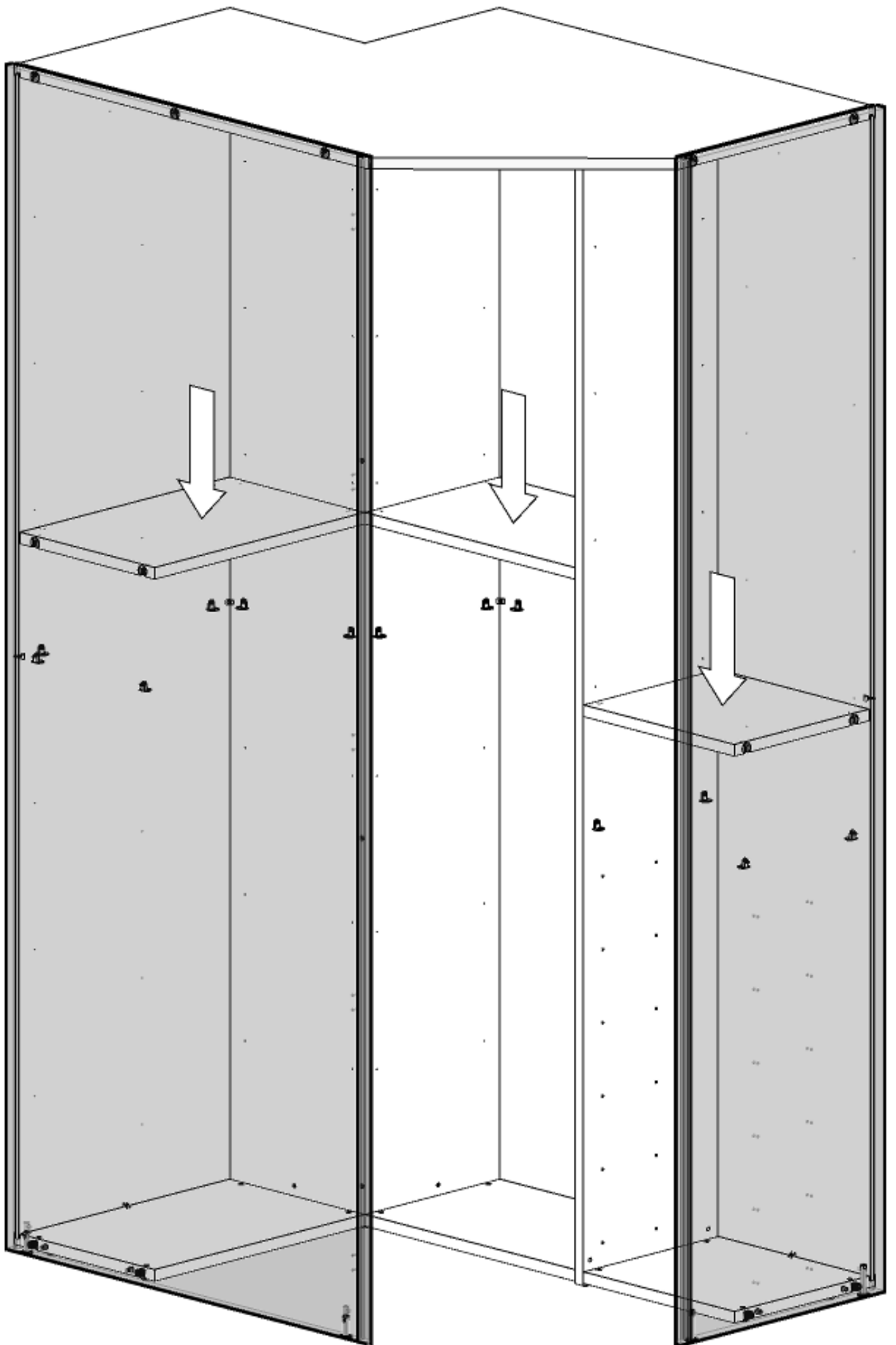

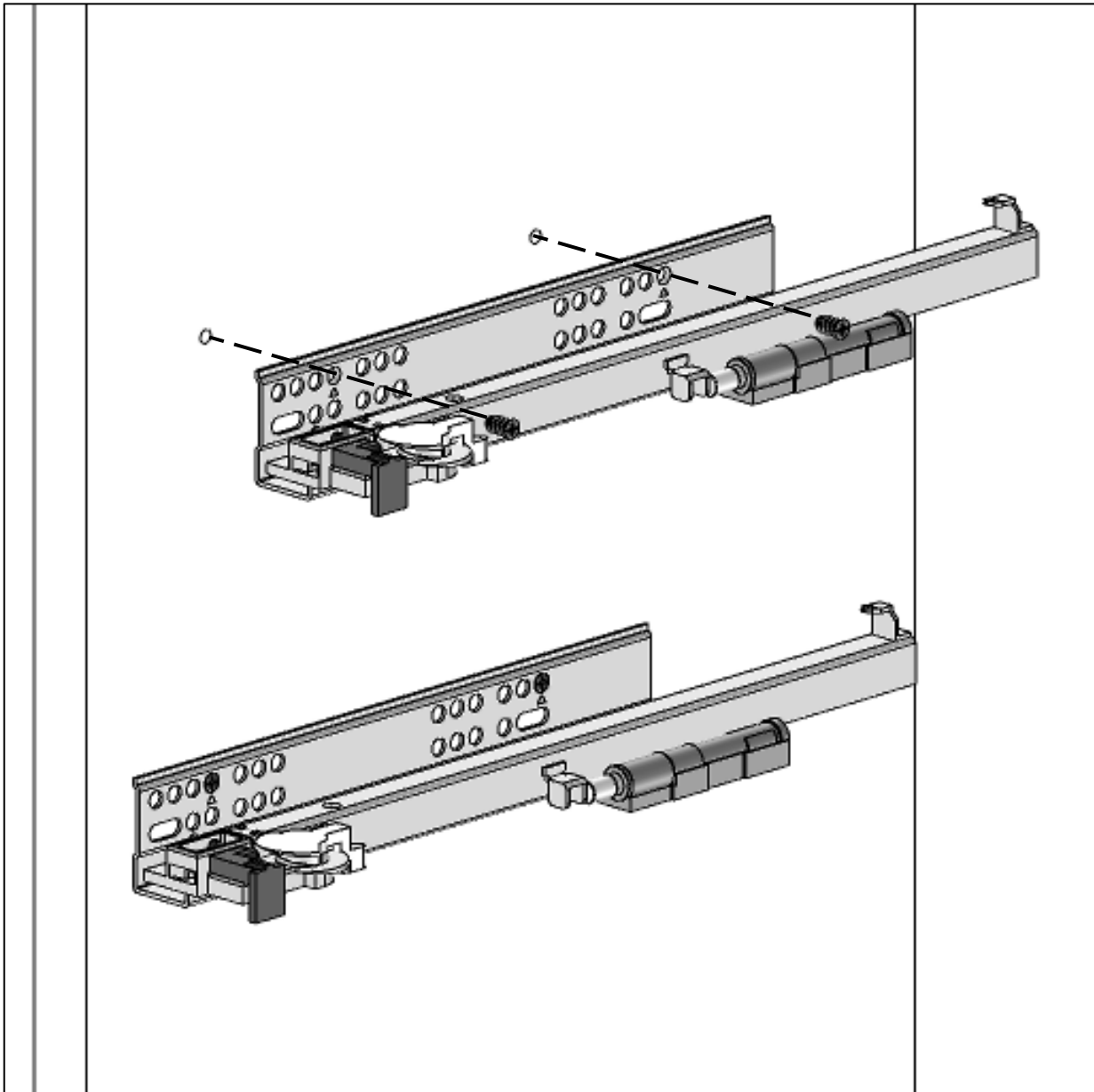
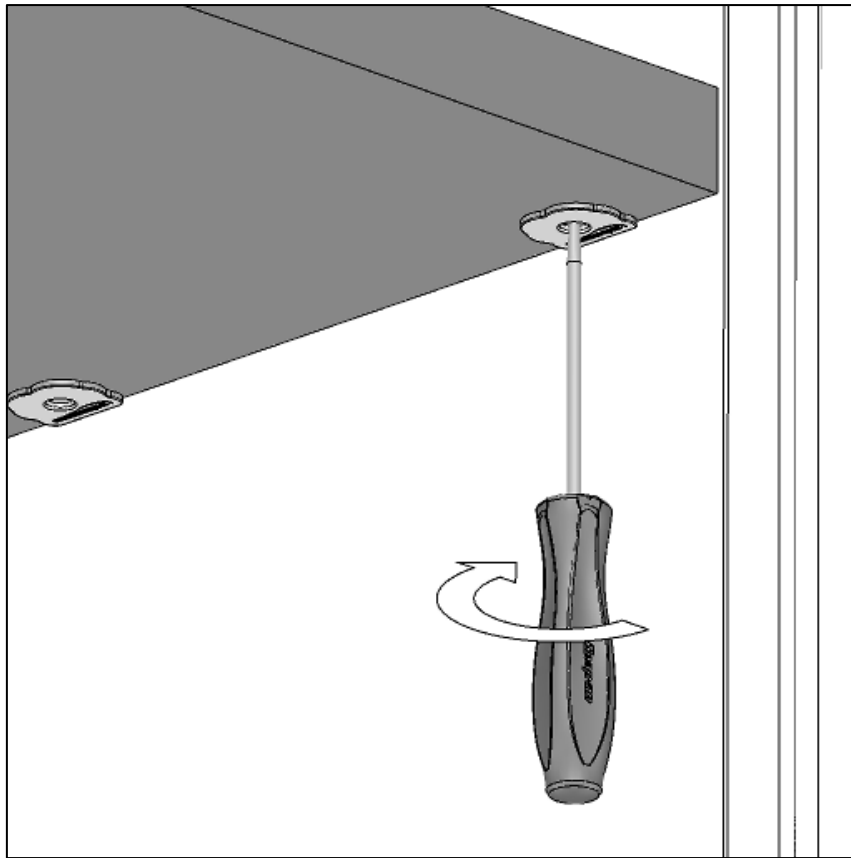

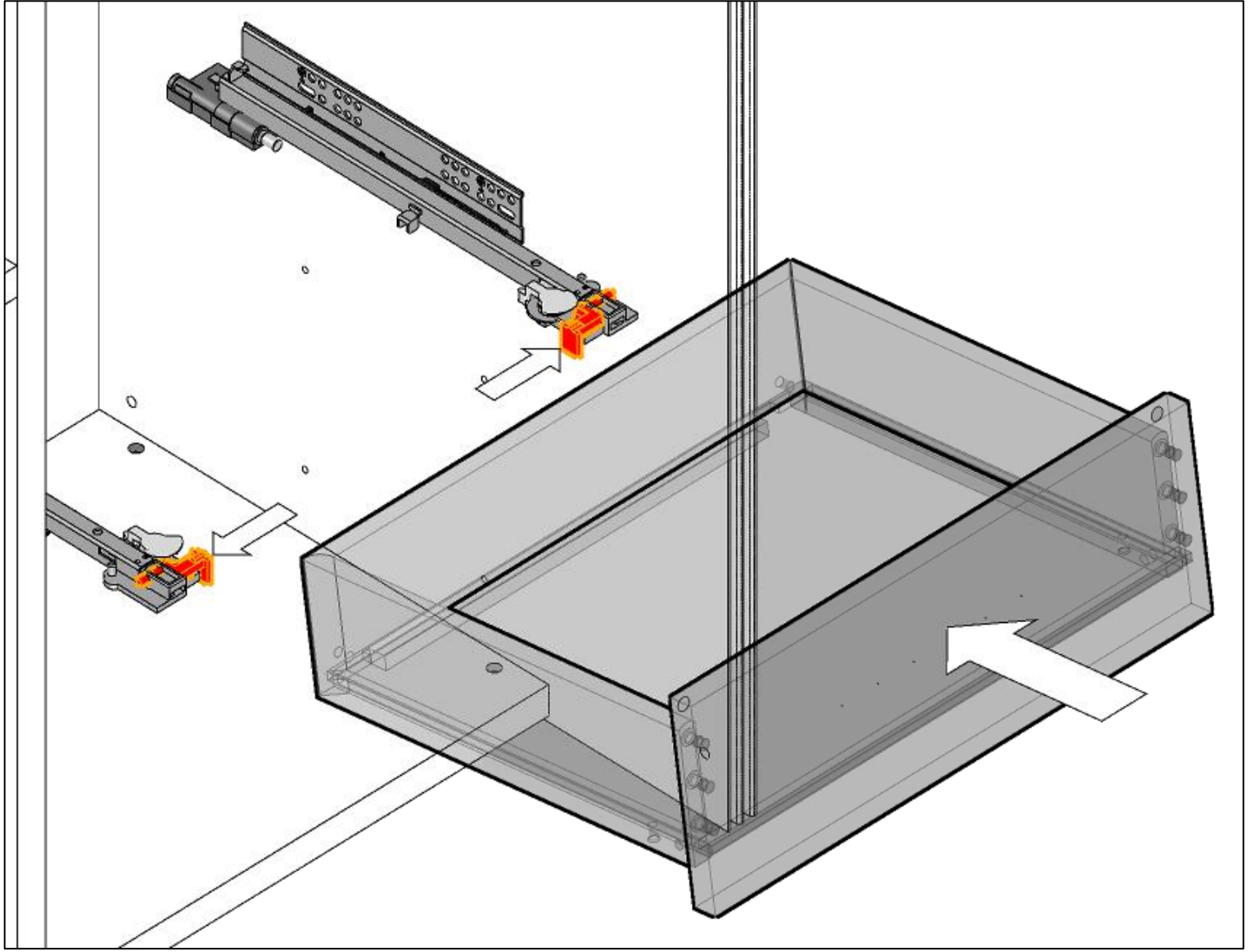

Posizione iniziale della leva per la regolazione verticale.

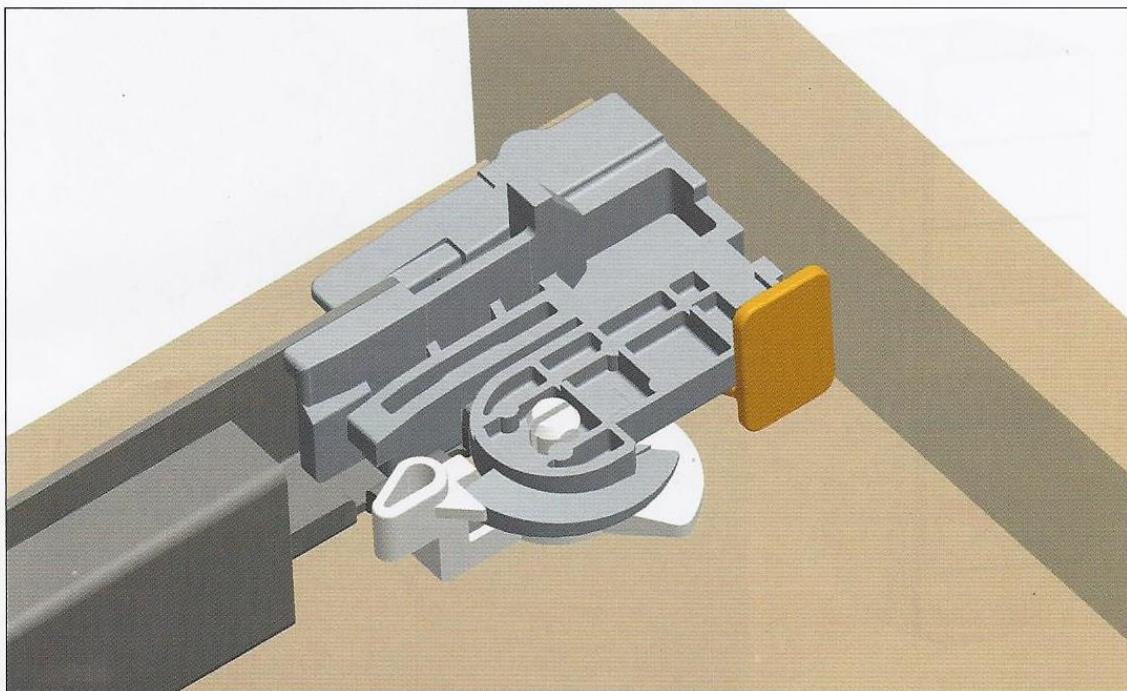
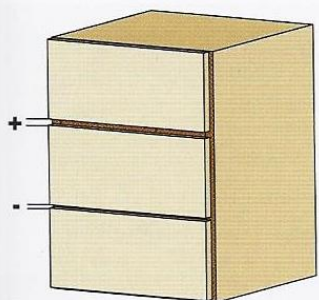

Ruotare la leva verso il frontale del cassetto per ottenere la regolazione verticale.

Questa operazione si effettua senza l'utilizzo di alcun utensile.

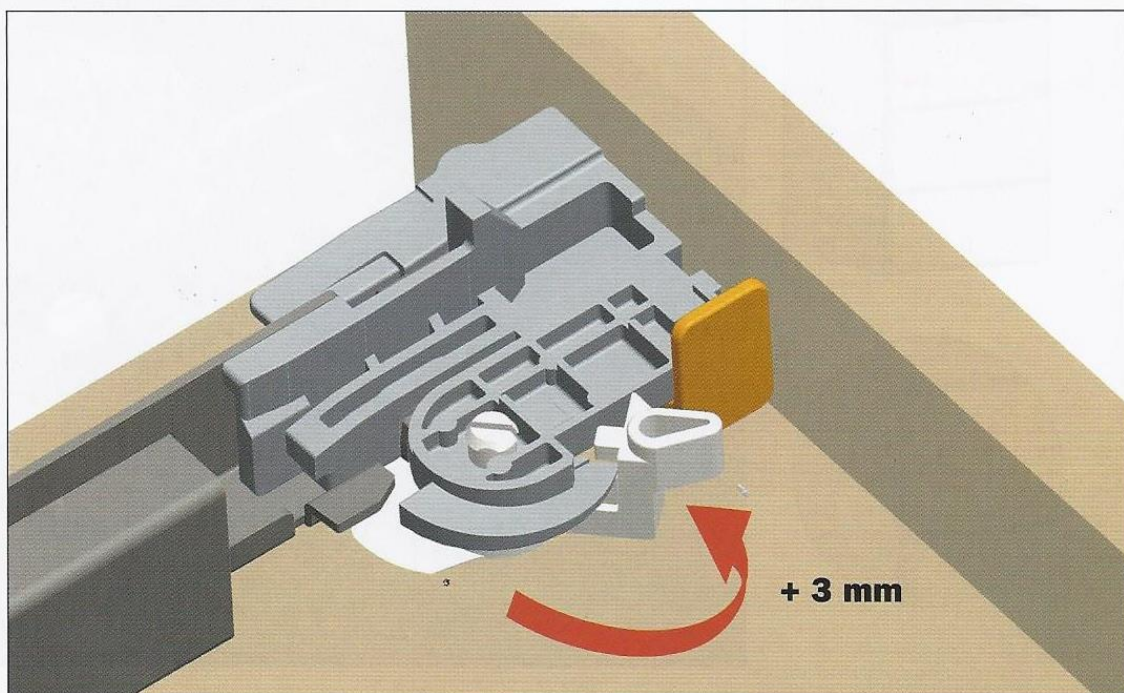
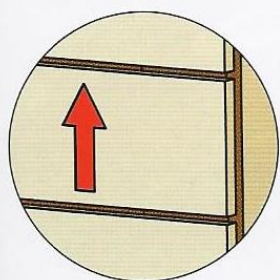
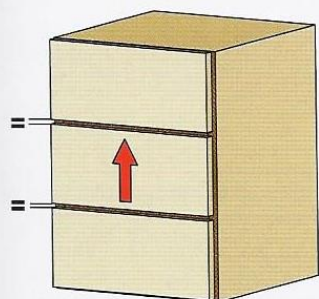

Ruotare la rotella nera verso il frontale del cassetto per aumentare l'aria tra il frontale e il fianco.

Questa operazione si effettua senza l'utilizzo di alcun utensile.

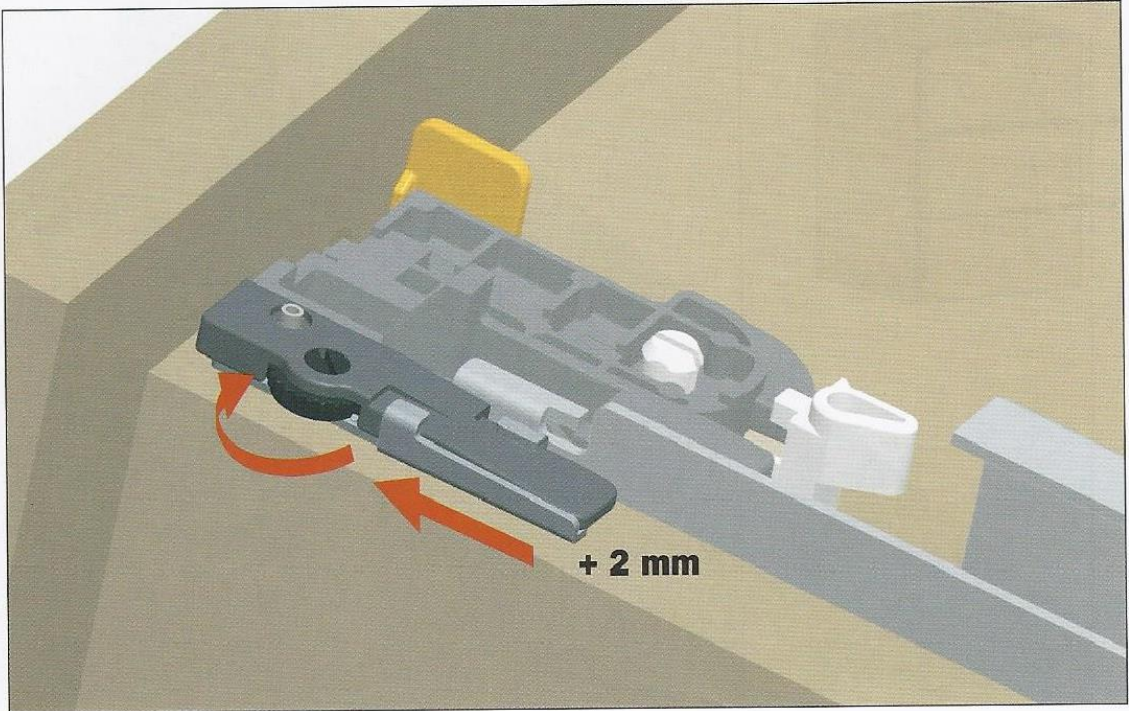
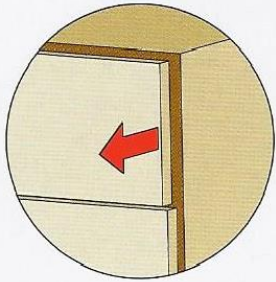
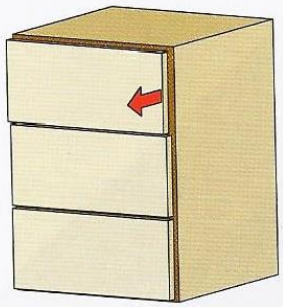

Ruotare la rotella nera verso il retro del cassetto per diminuire l'aria tra il frontale e il fianco.

Questa operazione si effettua senza l'utilizzo di alcun utensile.

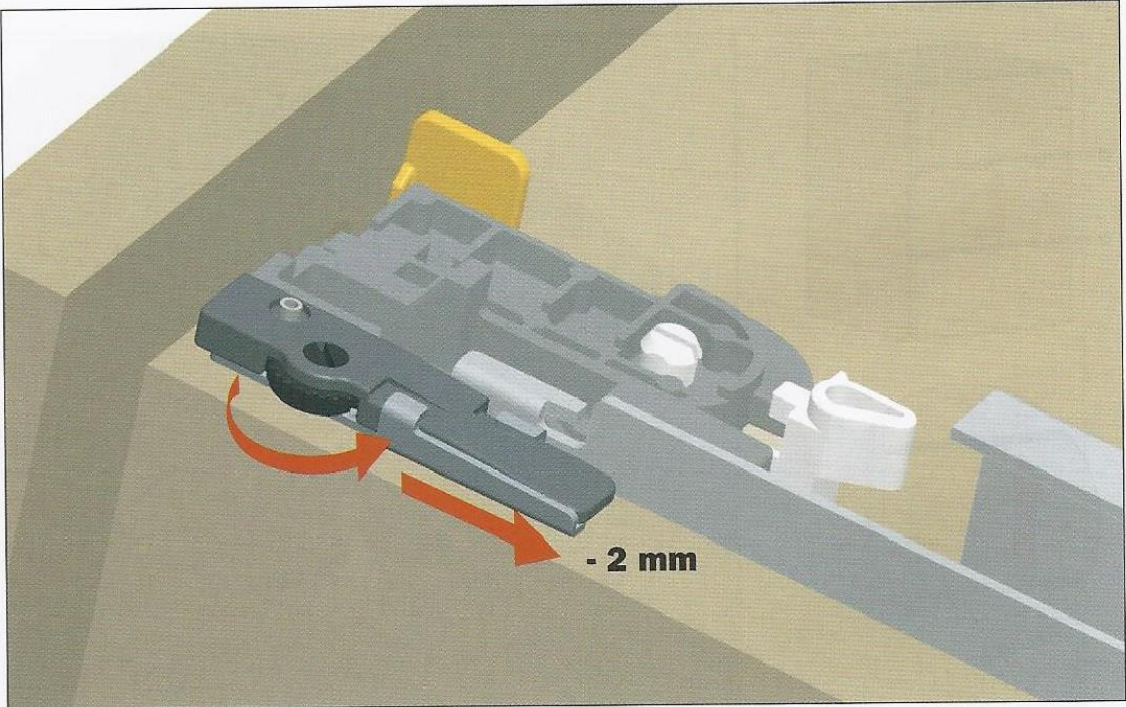
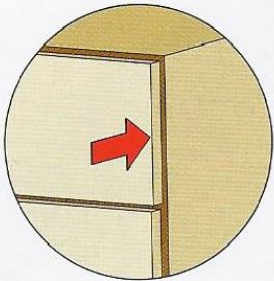
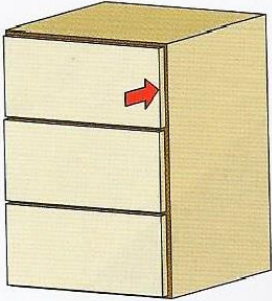

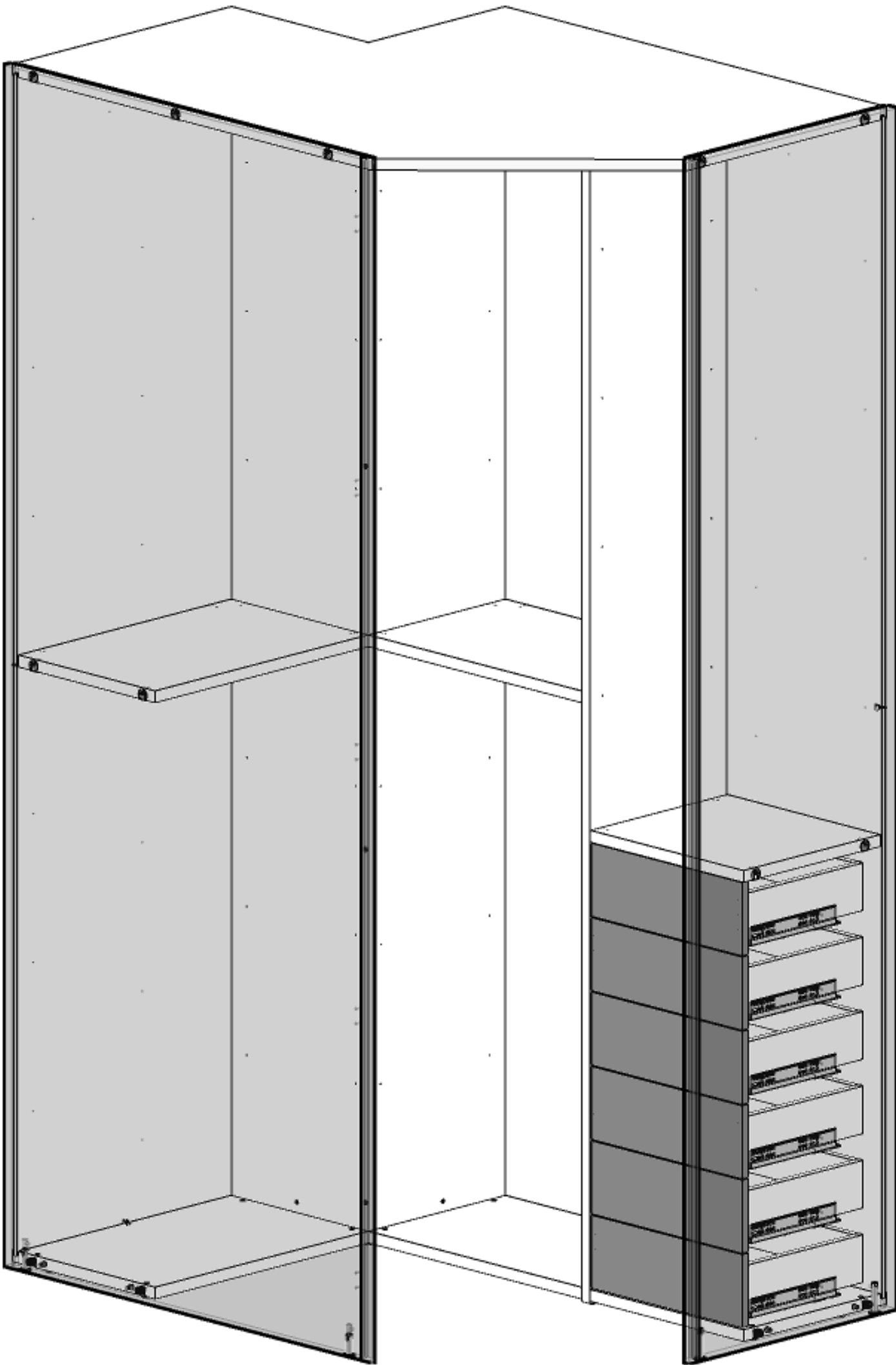

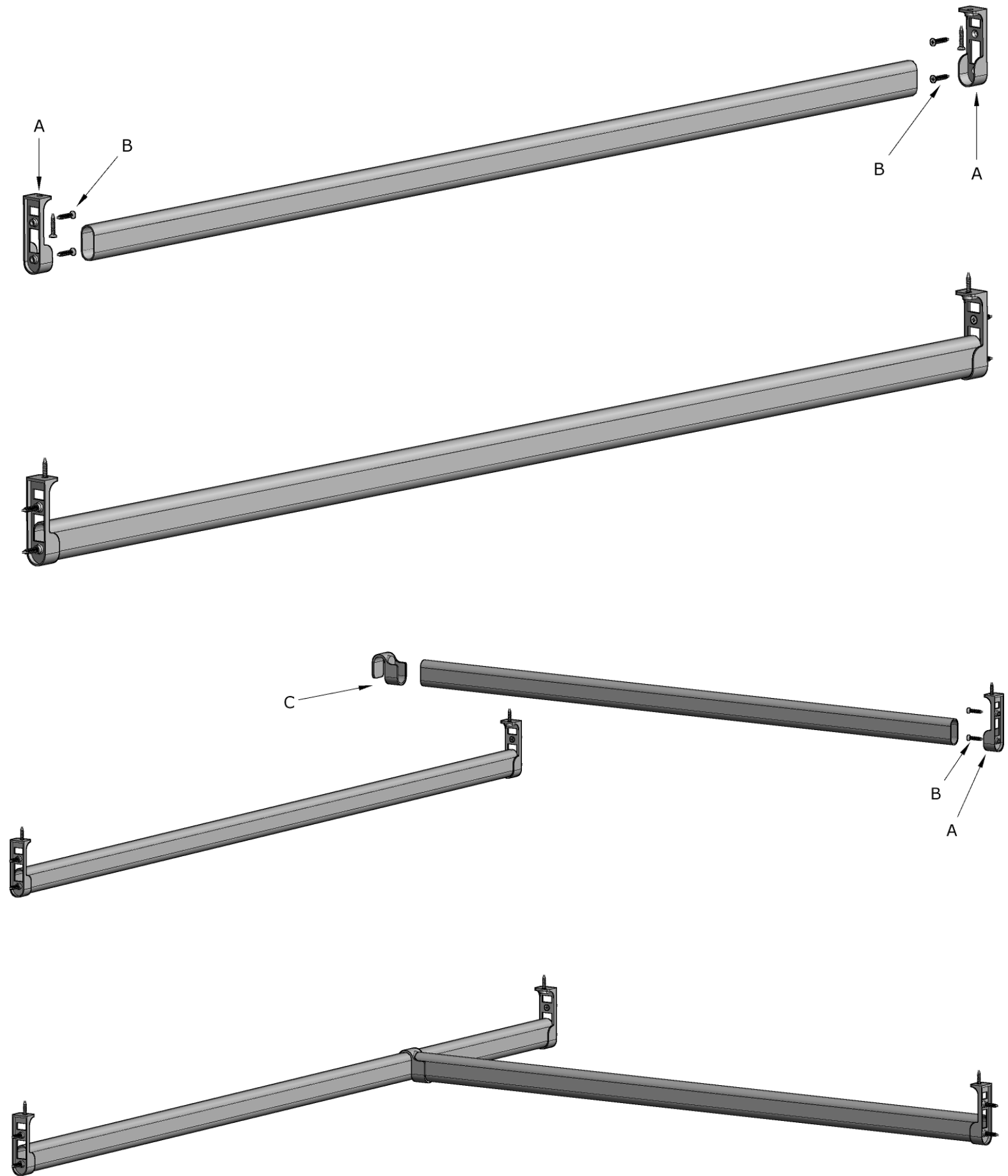

REGGITUBO

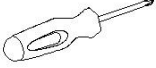

080005054 - SFR_Sac.Fr.Fissaggio Specchio

200001220	A		n°4	
200000935	B		n°13	

