

## Schemi montaggio *Assembling diagrams*

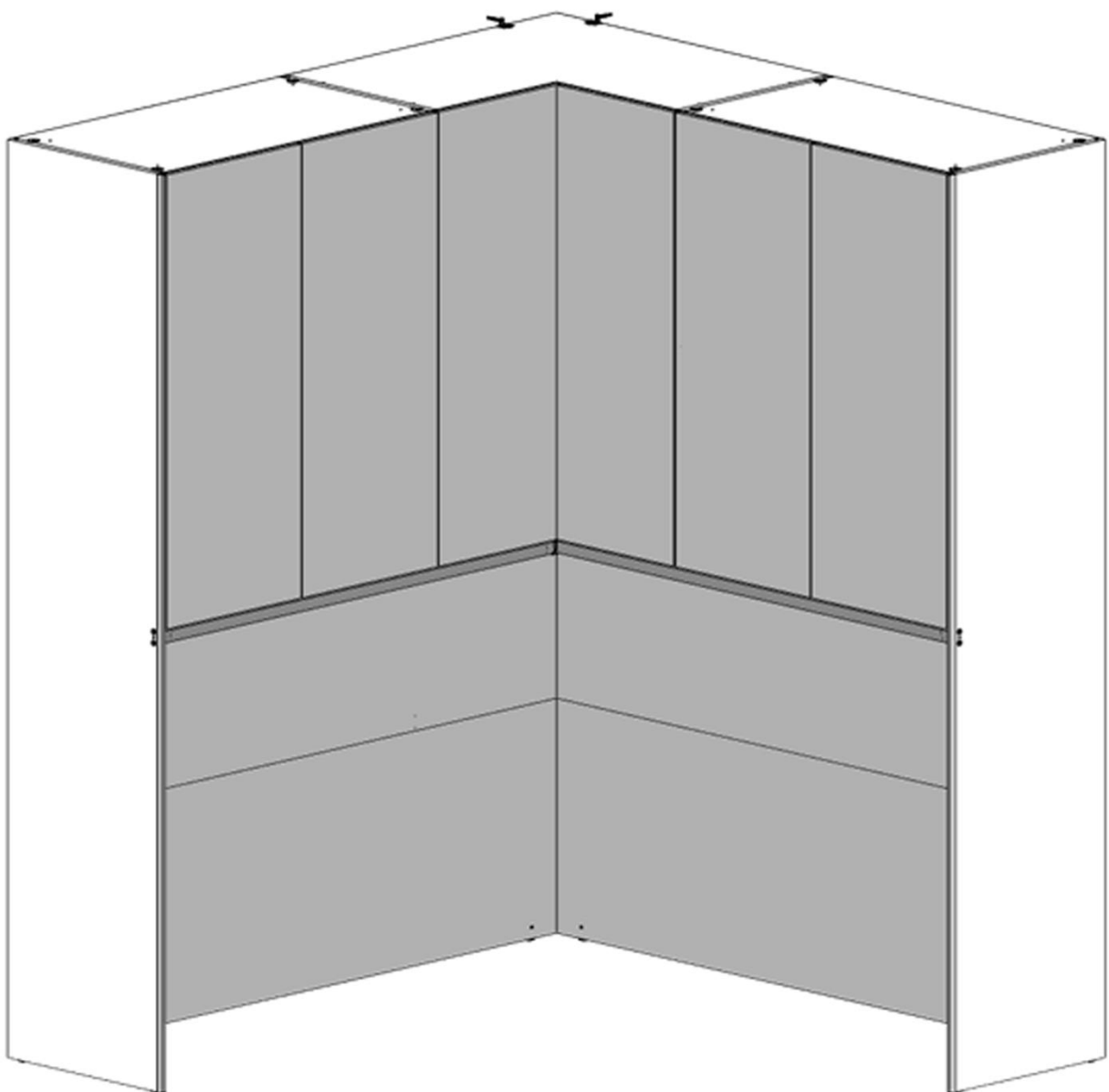

## PONTI ANGOLARI

ed. 02/2016 - rev. 2

SCMNT030

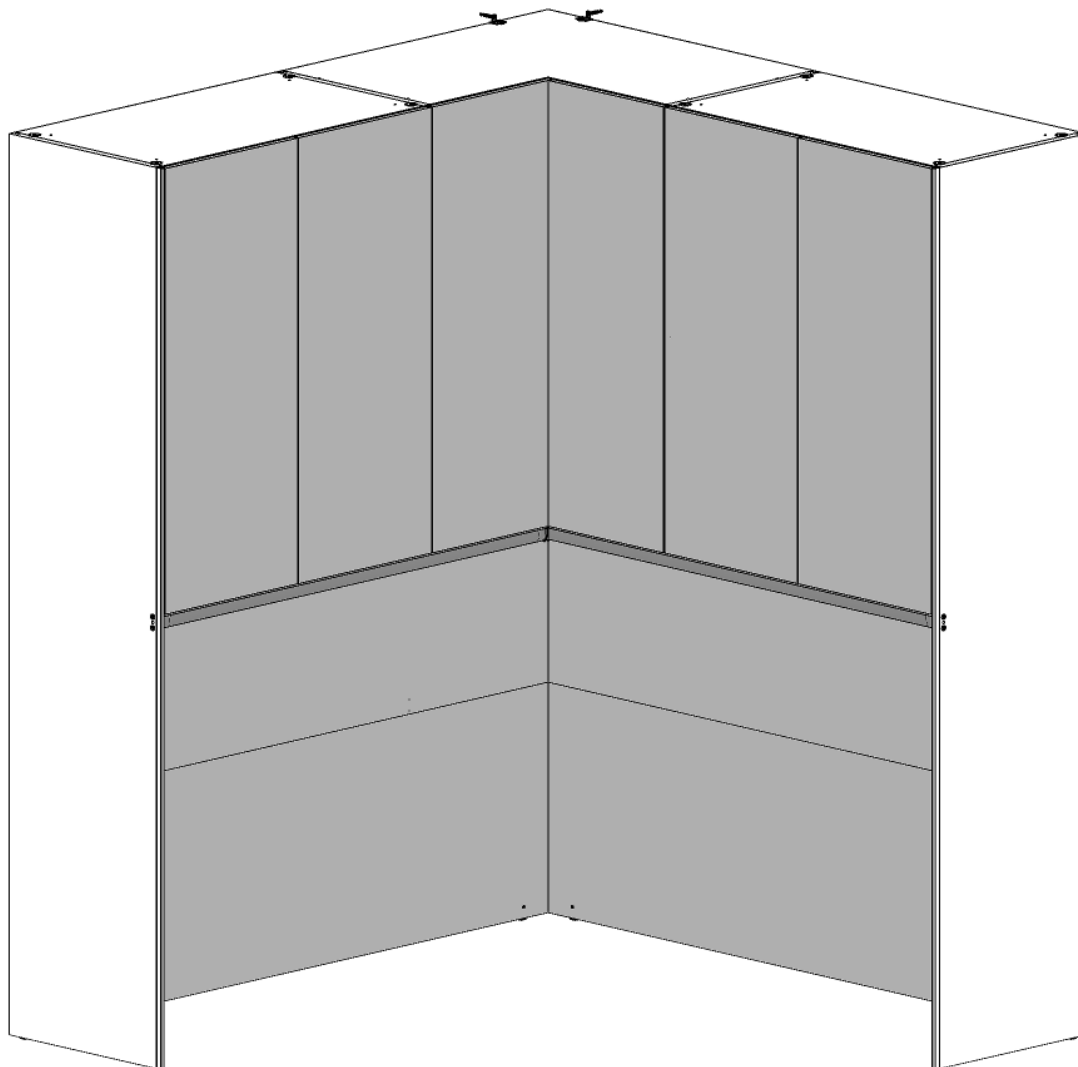

**080005179 - SFR\_Sac.Fr.Strt.Pnt.Angolo 2**

200000663	A		<b>n°10</b>	  
200000666	B		<b>n°17</b>	
200000653	C		<b>n°10</b>	
200000906	D		<b>n°6</b>	
200002161	E		<b>n°1</b>	
200003032	F		<b>n°2</b>	
200000667	G		<b>n°8</b>	
200000997	H		<b>n°2</b>	

**080005116 - SFR\_Sac.Fr.Ancorag.Mod.aParete**

200001912	I		<b>n°1</b>	 
200000950	J		<b>n°6</b>	
200000728	K		<b>n°1</b>	
200000959	L		<b>n°1</b>	
200000961	M		<b>n°1</b>	

**080005116 - SFR\_Sac.Fr.Ancorag.Mod.aParete**

200001912	I		<b>n°1</b>	 
200000950	J		<b>n°6</b>	
200000728	K		<b>n°1</b>	
200000959	L		<b>n°1</b>	
200000961	M		<b>n°1</b>	

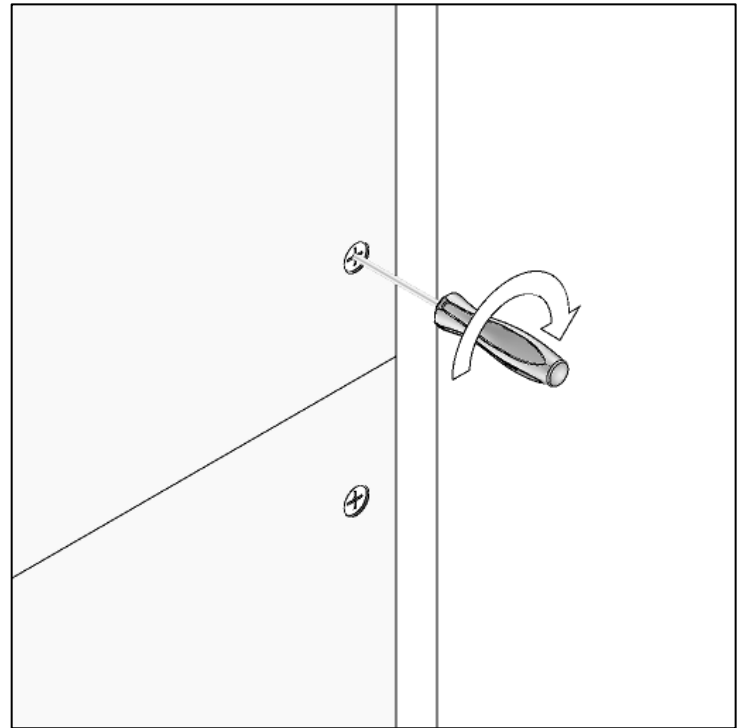
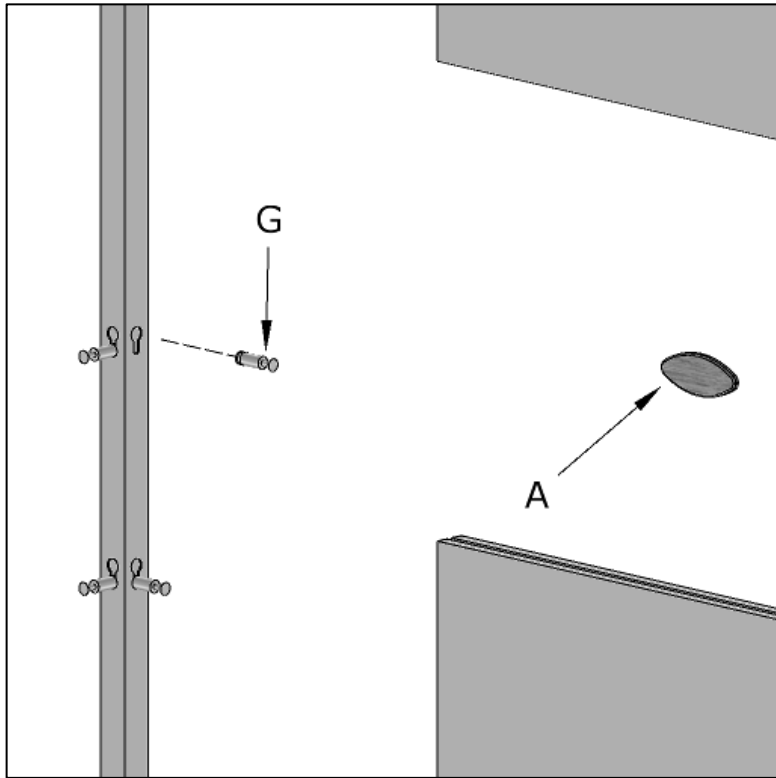
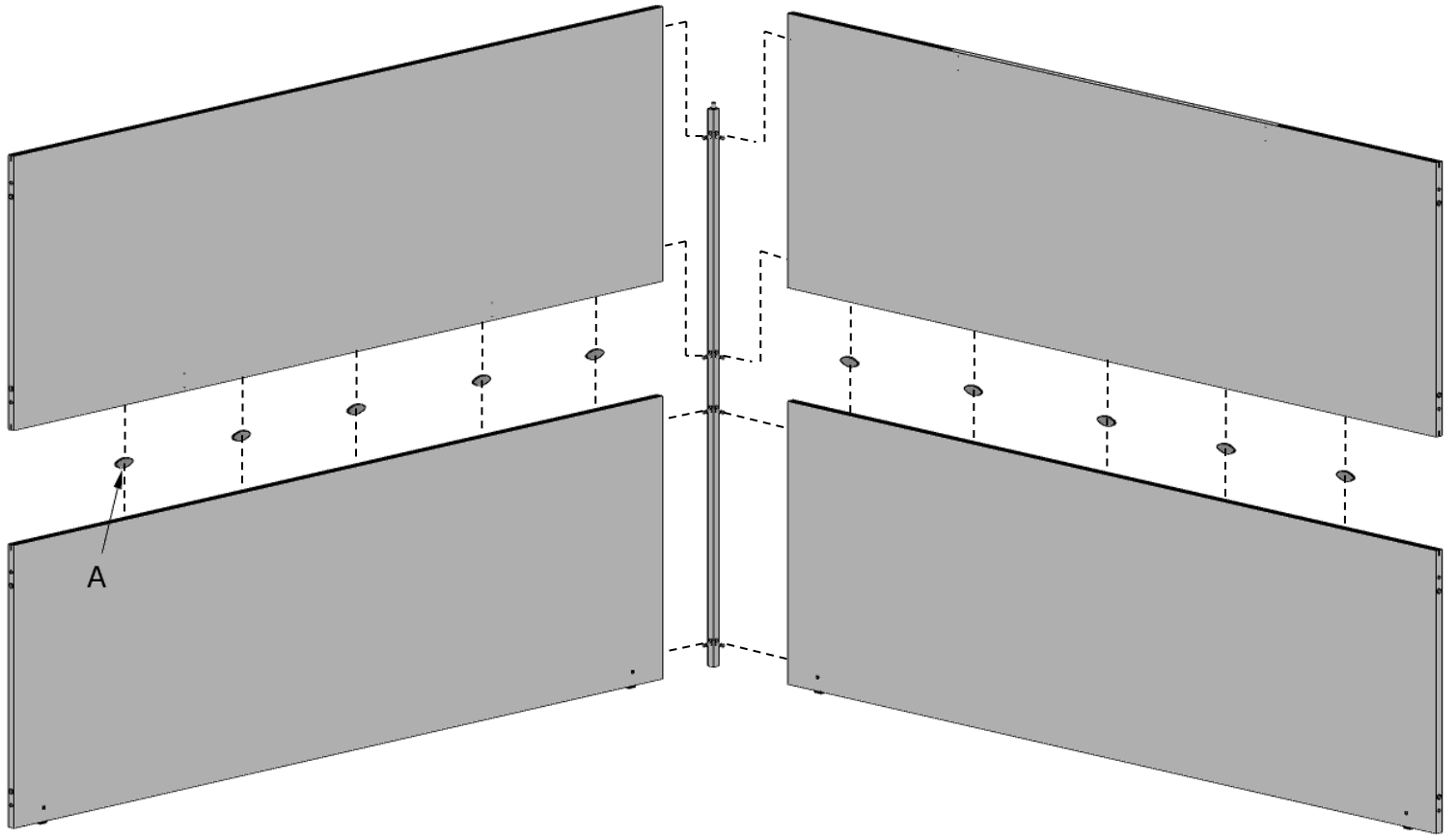



Ø7

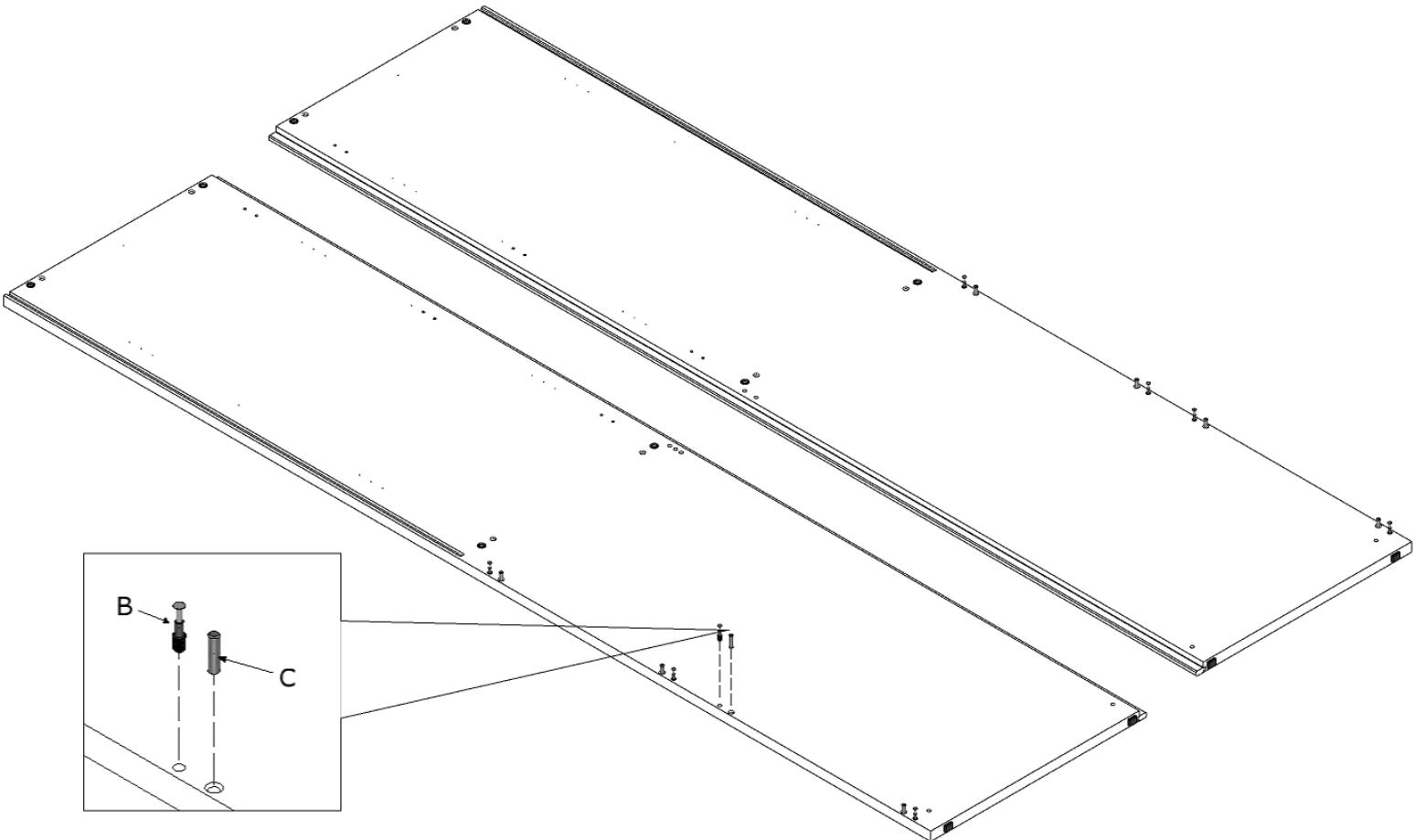
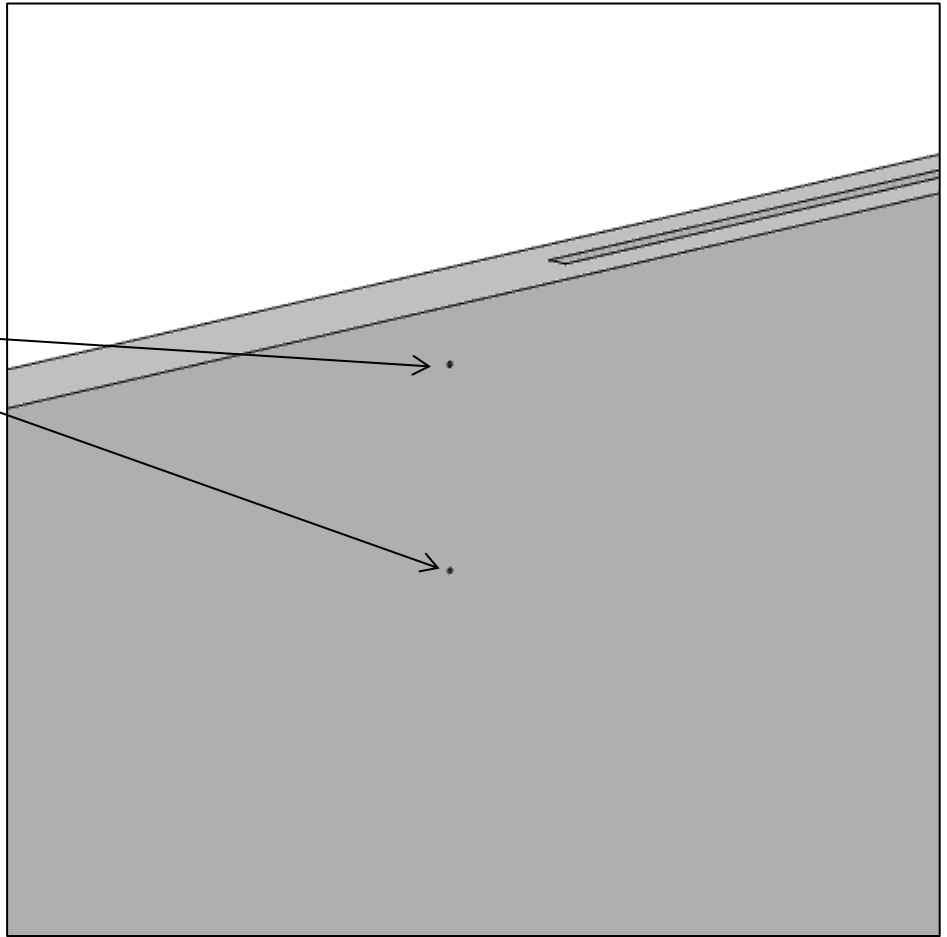
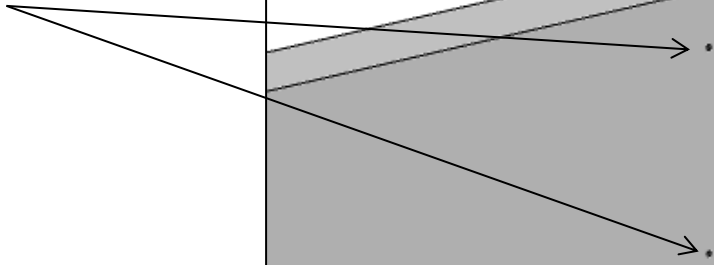

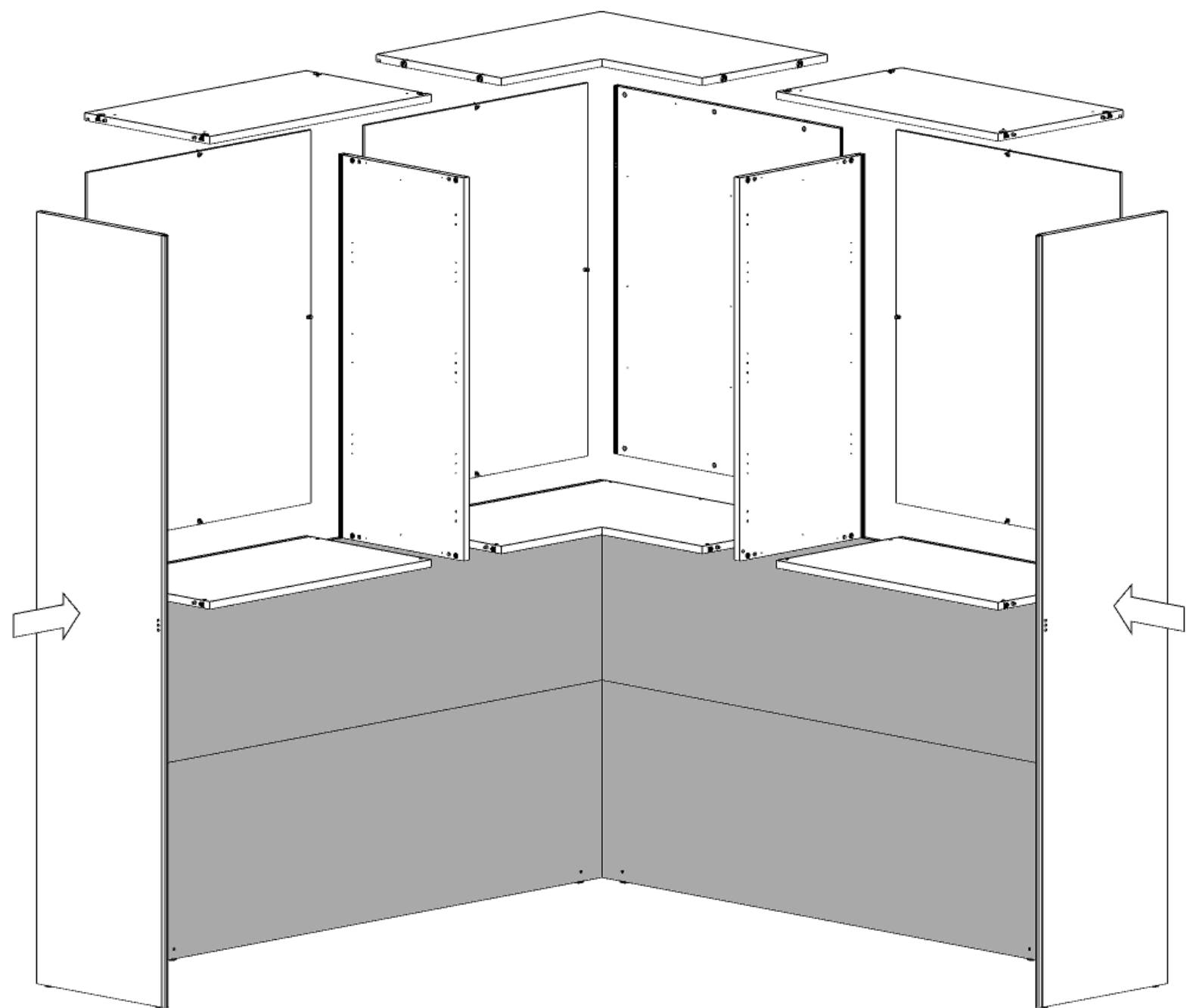

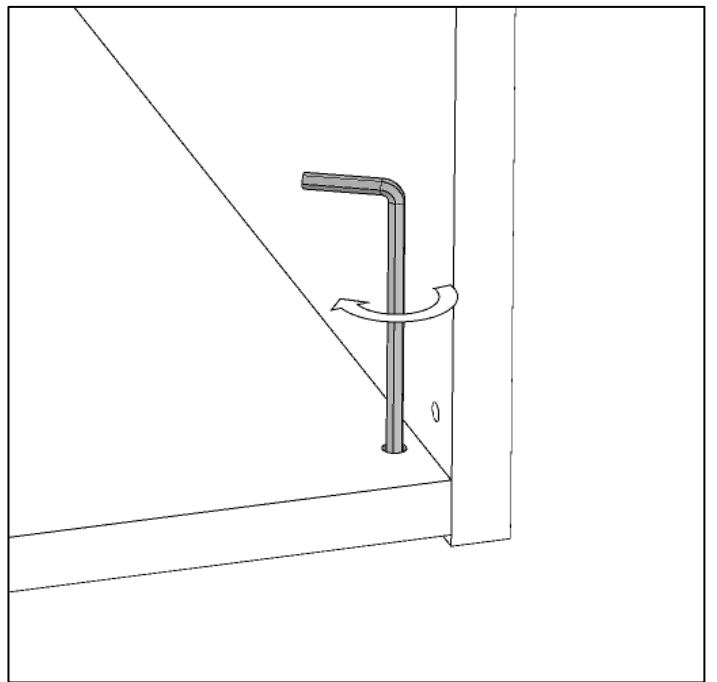
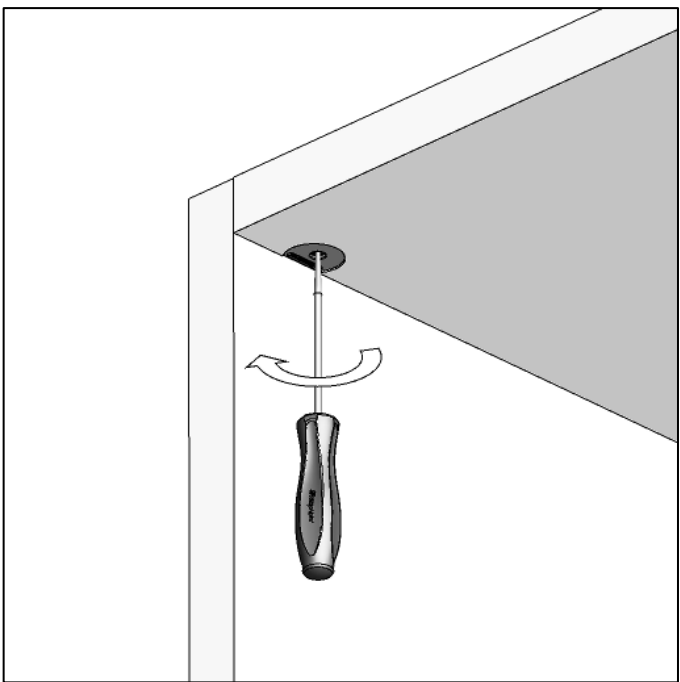
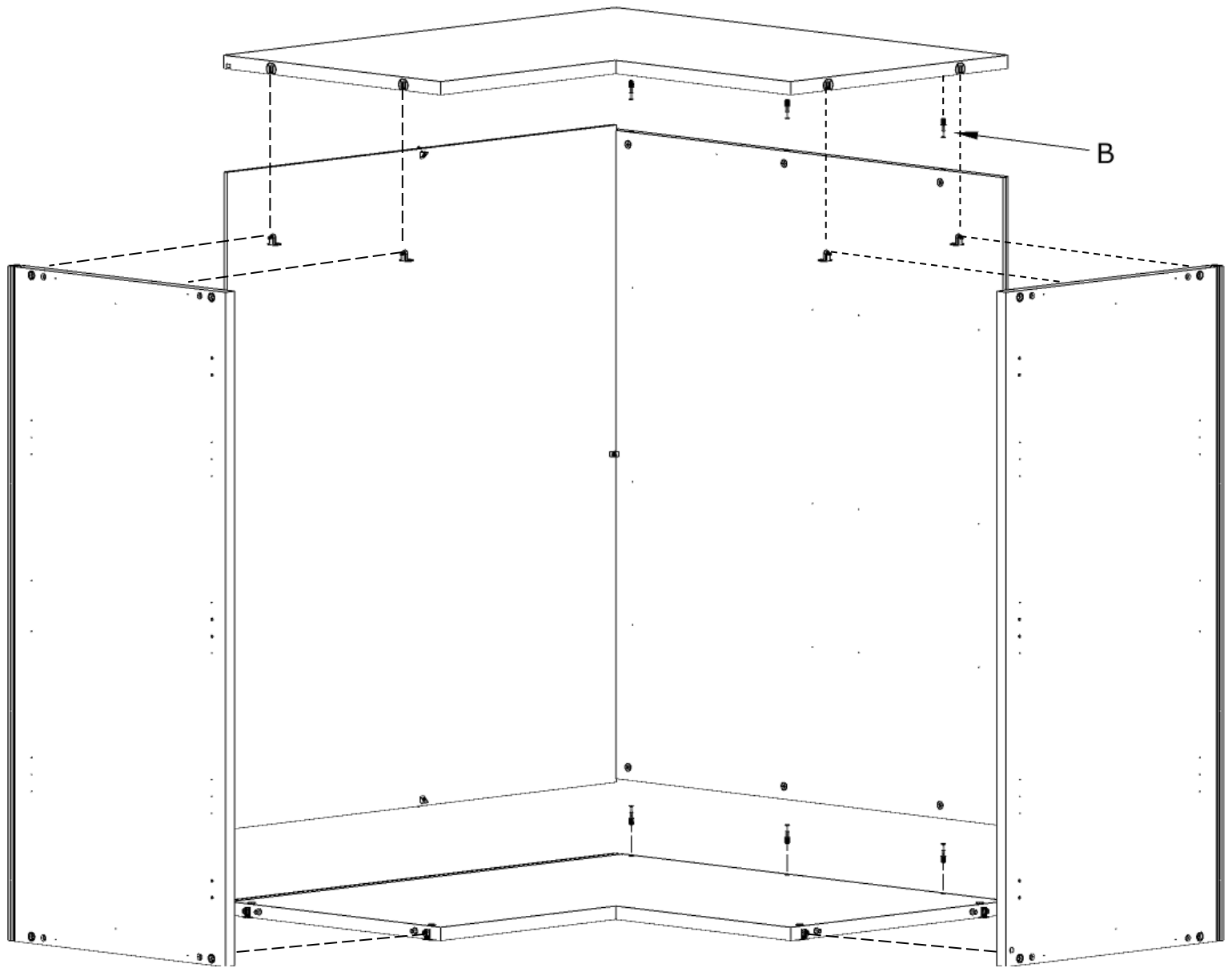



**ATTENZIONE!**  
**L'ANGOLO DEVE**  
**ESSERE ANCORATO**  
**OBBLIGATORIAMENTE**  
**SU ENTRAMBI I LATI**

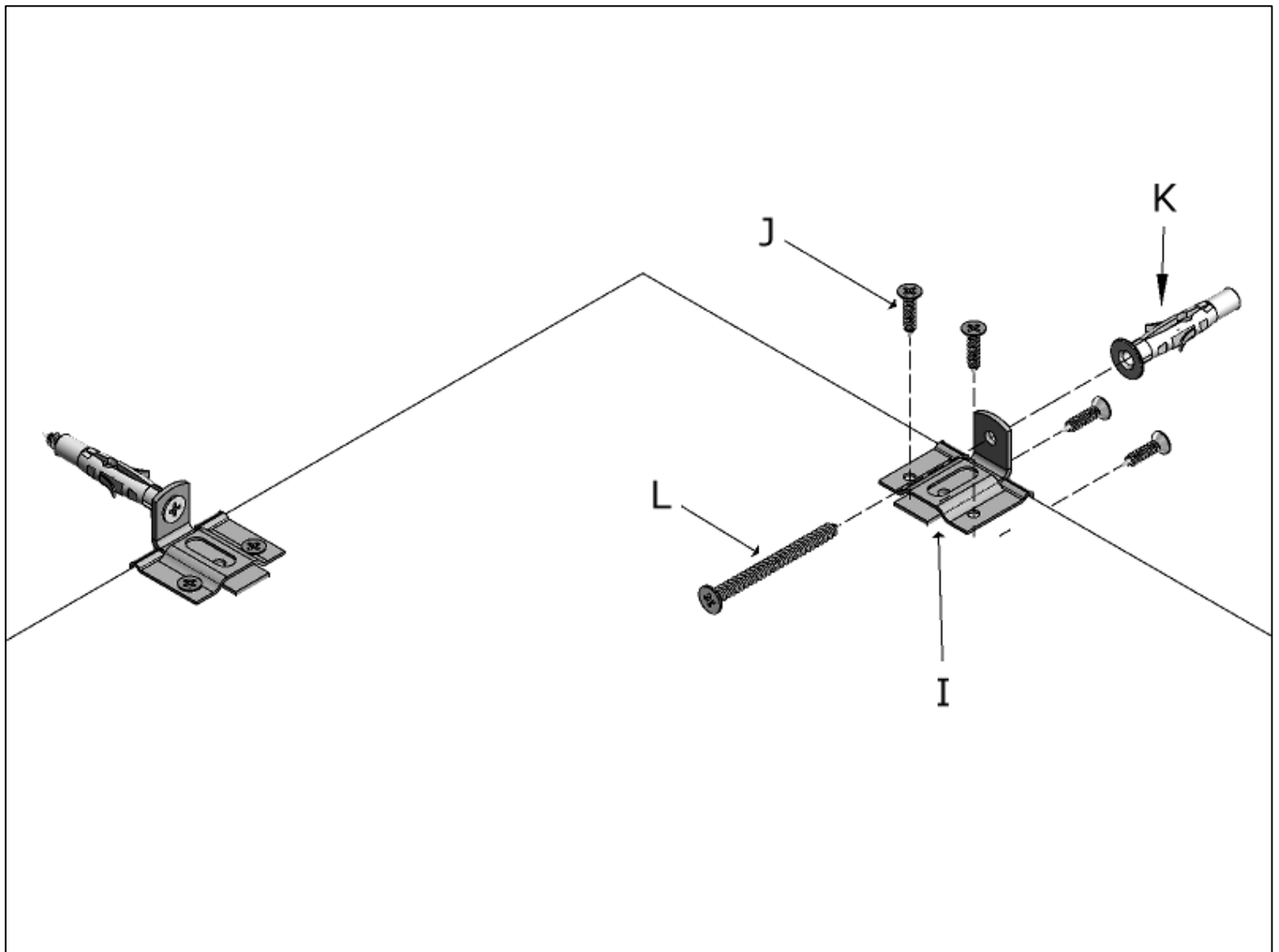

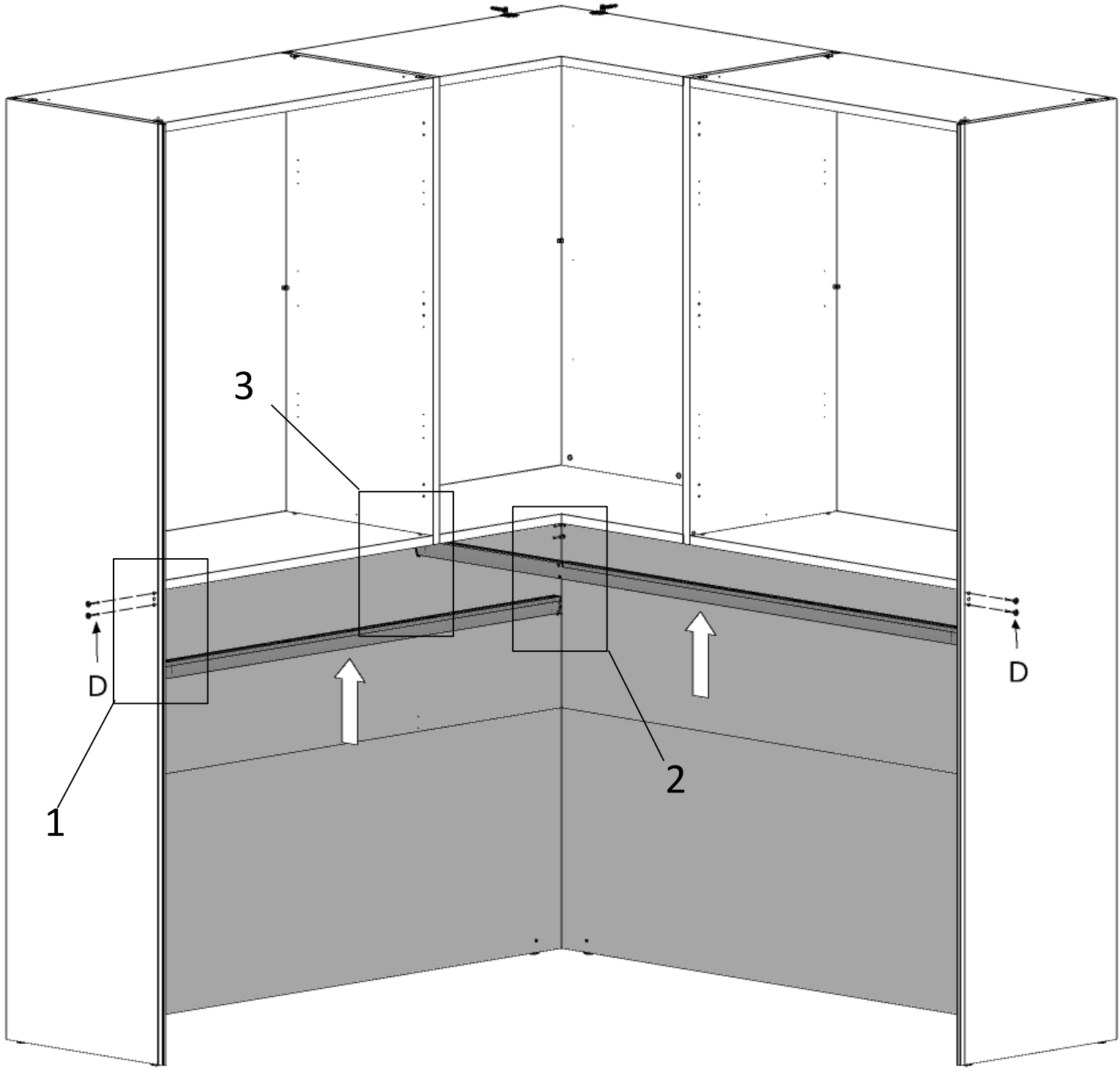



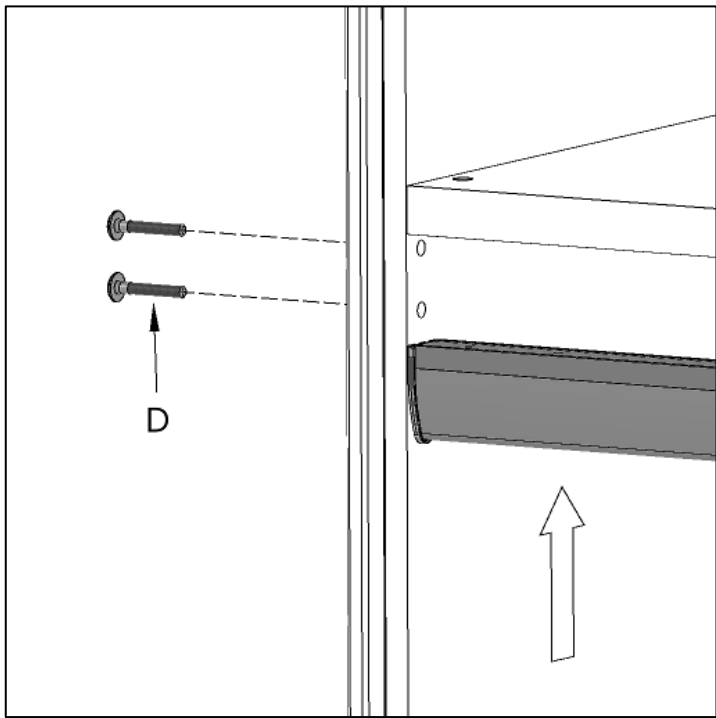

1

2

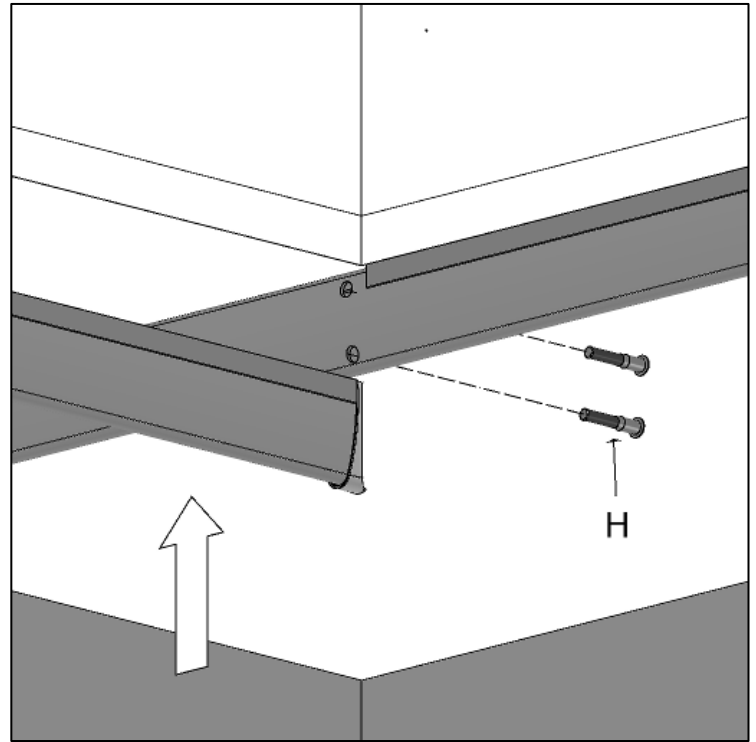

3

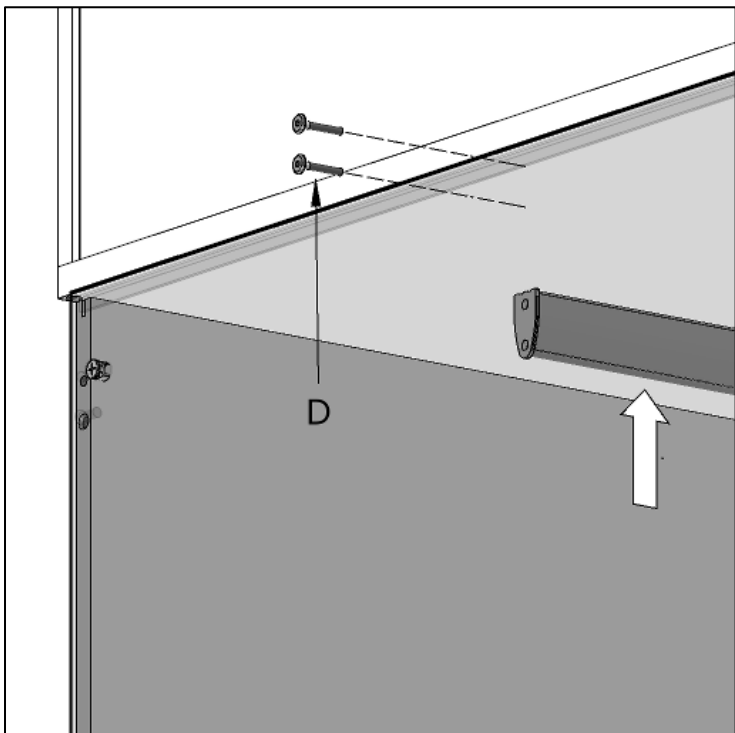



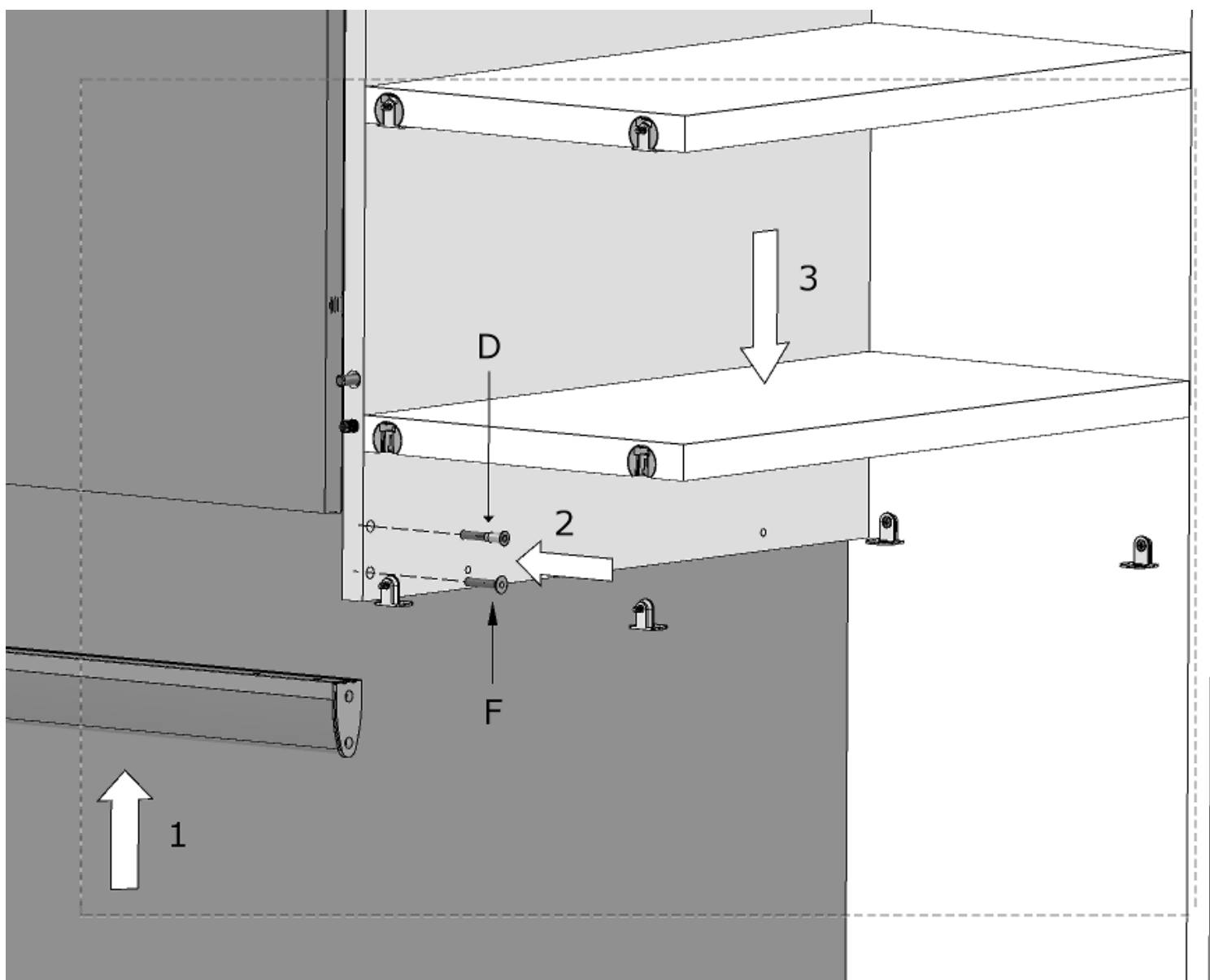

## IN PRESENZA DI MODULI AFFIANCATI

Sostituire la vite "D" (solo quella che crea conflitto con il modulo affiancato)  
con la vite "F" come da disegno

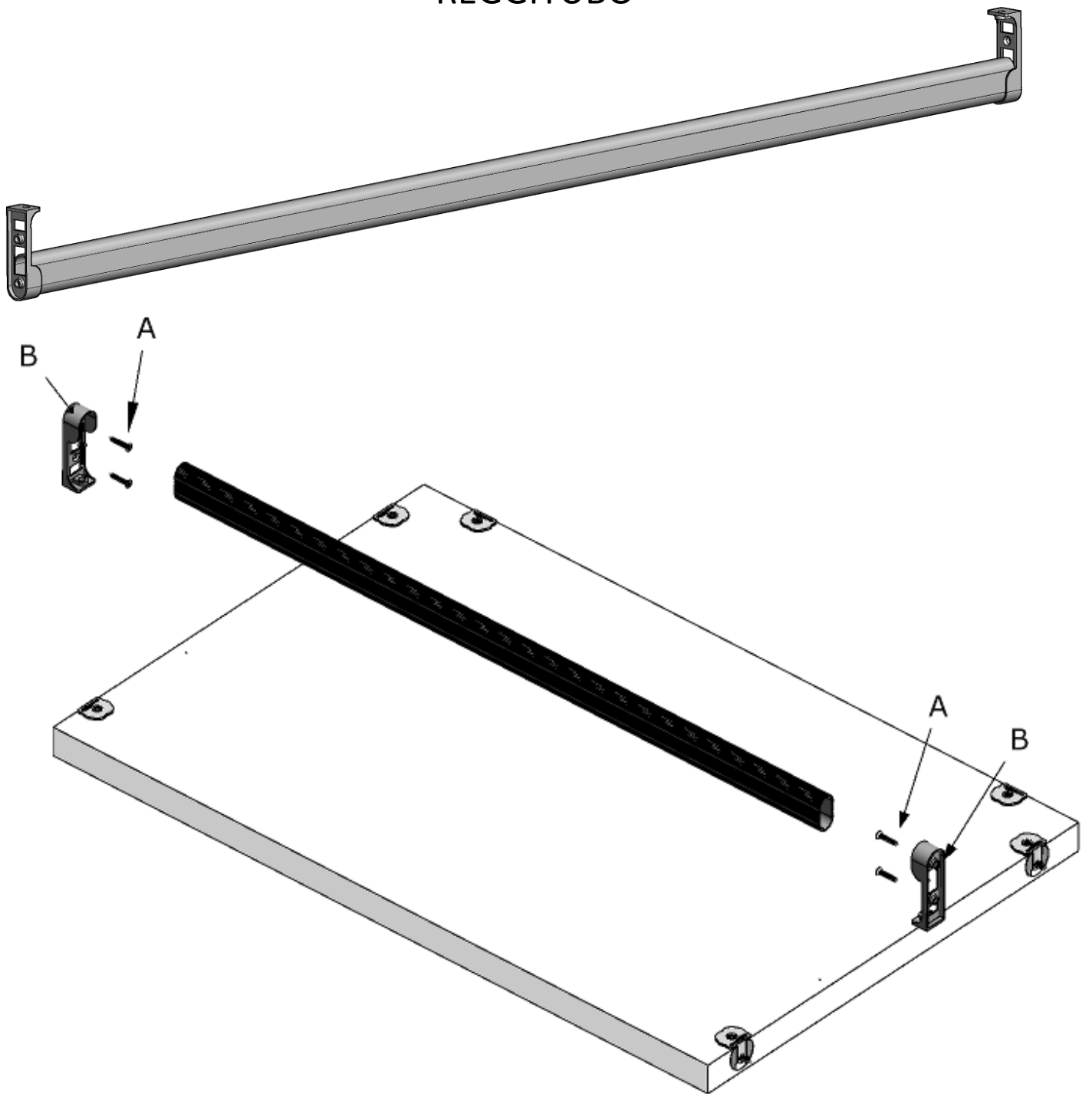





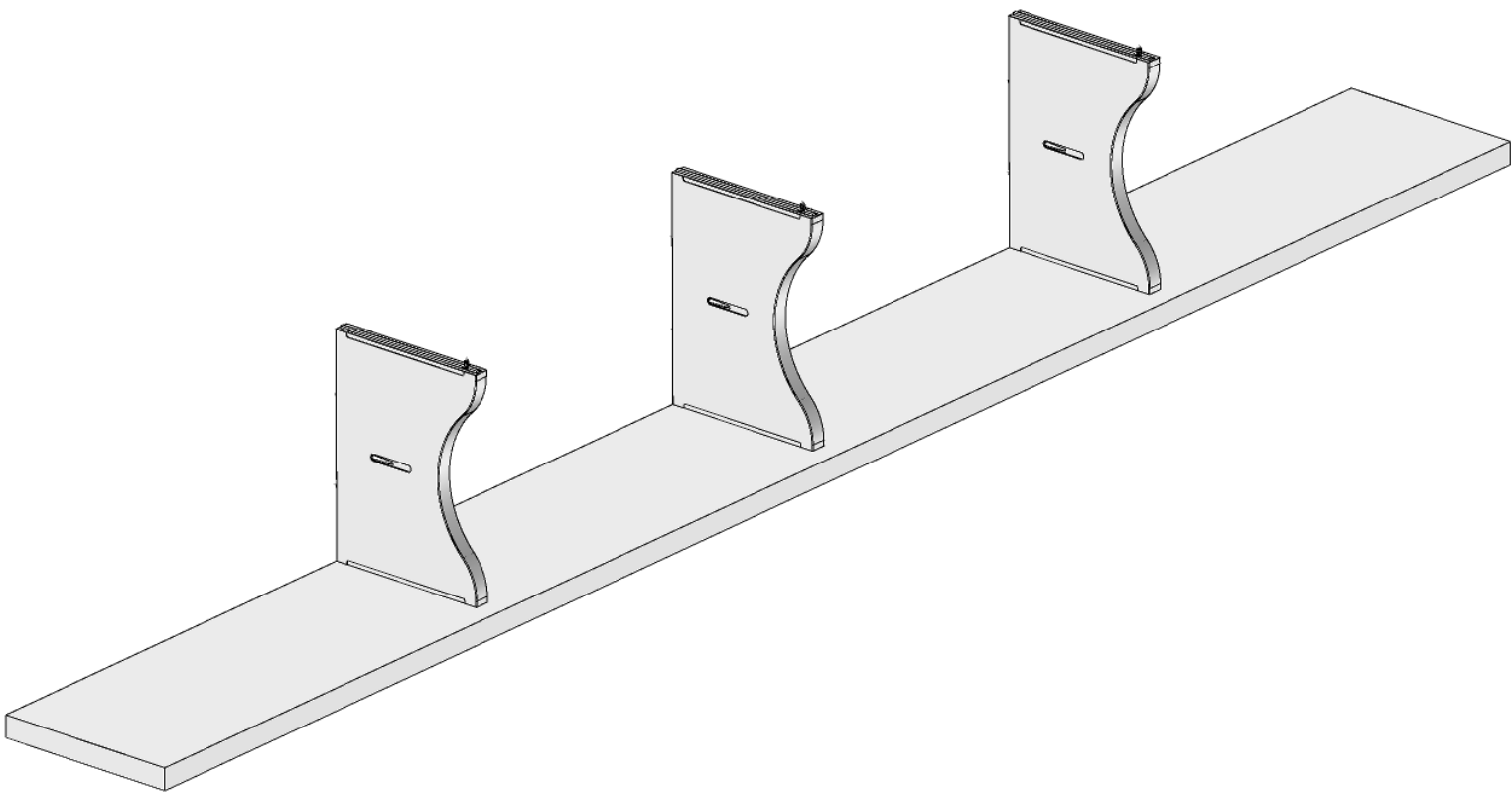

# REGGITUBO







A		n°6	
B		n°2	





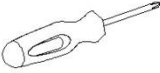

**080005918 - SFR\_Sac.Fr.Fiss.2 Supp.Mens.Sott**

200000975	A		<b>n°4</b>	
200000954	B		<b>n°6</b>	
200002042	C		<b>n°2</b>	
200000938	D		<b>n°4</b>	
				

**080005919 - SFR\_Sac.Fr.Fiss.3 Supp.Mens.Sott**

200000975	A		<b>n°6</b>	
200000954	B		<b>n°9</b>	
200002042	C		<b>n°2</b>	
200000938	D		<b>n°4</b>	
				

**080005920 - SFR\_Sac.Fr.Fiss.4 Supp.Mens.Sott**

200000975	A		<b>n°8</b>	
200000954	B		<b>n°12</b>	
200002042	C		<b>n°2</b>	
200000938	D		<b>n°4</b>	
