

**Schemi montaggio**  
*Assembling diagrams*

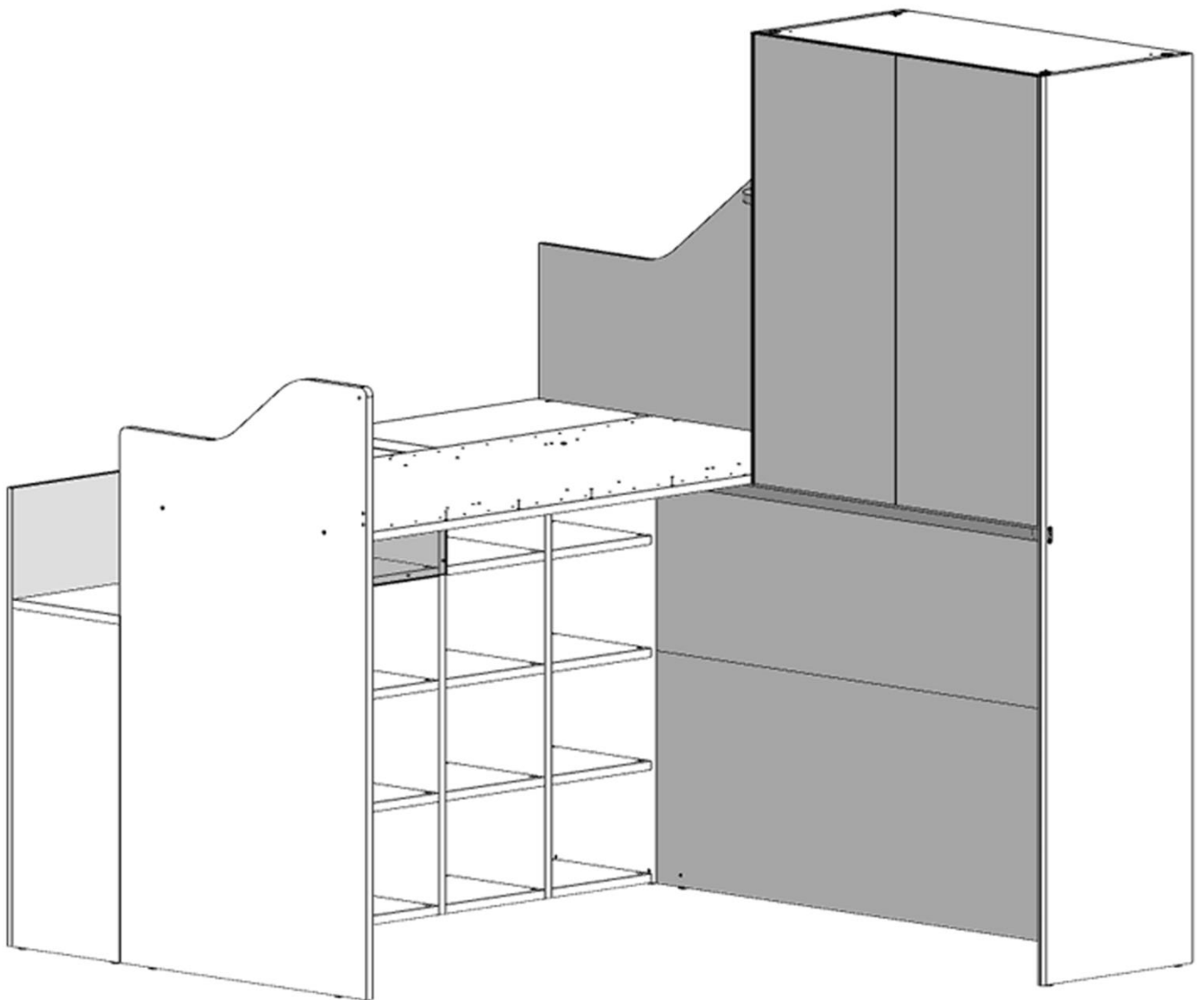









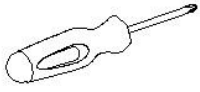





**CONCEPT EVO**





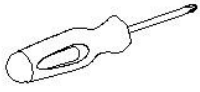





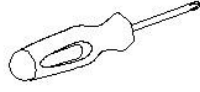



ed. 04/2016 - rev. 3

SCMNT019



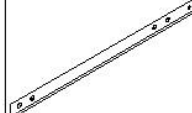

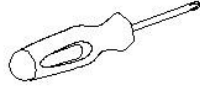
**080005846 - SFR\_Sac.Fr.Strt.CncEVO Scl.Lat**

200000906	A		<b>n°4</b>	
200000953	B		<b>n°2</b>	
200000996	C		<b>n°7</b>	
200000666	E		<b>n°20</b>	
200000653	F		<b>n°20</b>	
200000663	G		<b>n°10</b>	
200002161	H		<b>n°1</b>	
200002991	I		<b>n°2</b>	
200002659	J		<b>n°2</b>	
200000952	K		<b>n°12</b>	
200003032	L		<b>n°2</b>	

**080005847 - SFR\_Sac.Fr.Strt.CncEVO Scl.Pst**

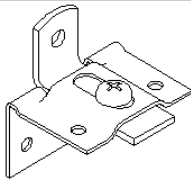
200000906	A		<b>n°4</b>	
200000953	B		<b>n°2</b>	
200000996	C		<b>n°7</b>	
200000666	E		<b>n°20</b>	
200000653	F		<b>n°20</b>	
200000663	G		<b>n°10</b>	
200002161	H		<b>n°1</b>	
200002991	I		<b>n°2</b>	
200002659	J		<b>n°2</b>	
200000952	K		<b>n°12</b>	
200003032	L		<b>n°2</b>	

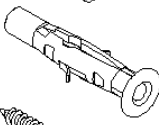
**080005116 - SFR\_Sac.Fr.Ancorag.Mod.aParete**

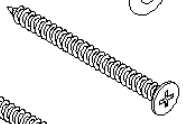
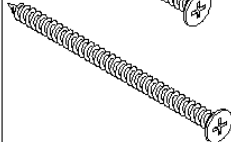
200001912	N		<b>n°1</b>	
200000950	O		<b>n°6</b>	
200000728	P		<b>n°1</b>	
200000959	Q		<b>n°1</b>	
200000961	R		<b>n°1</b>	

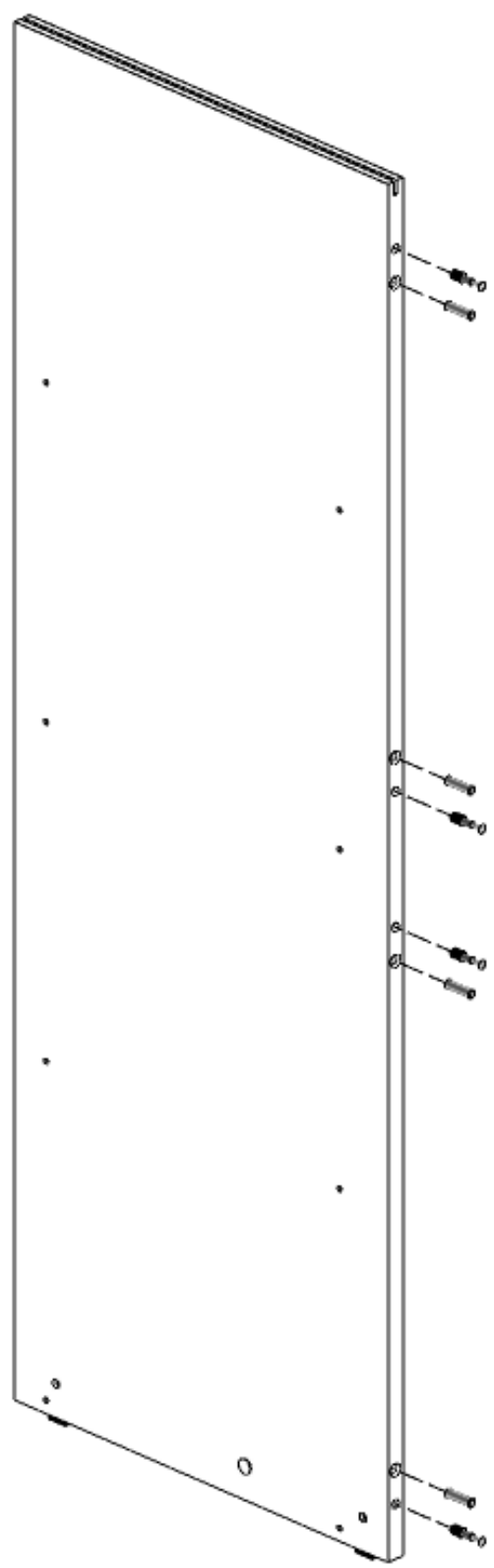
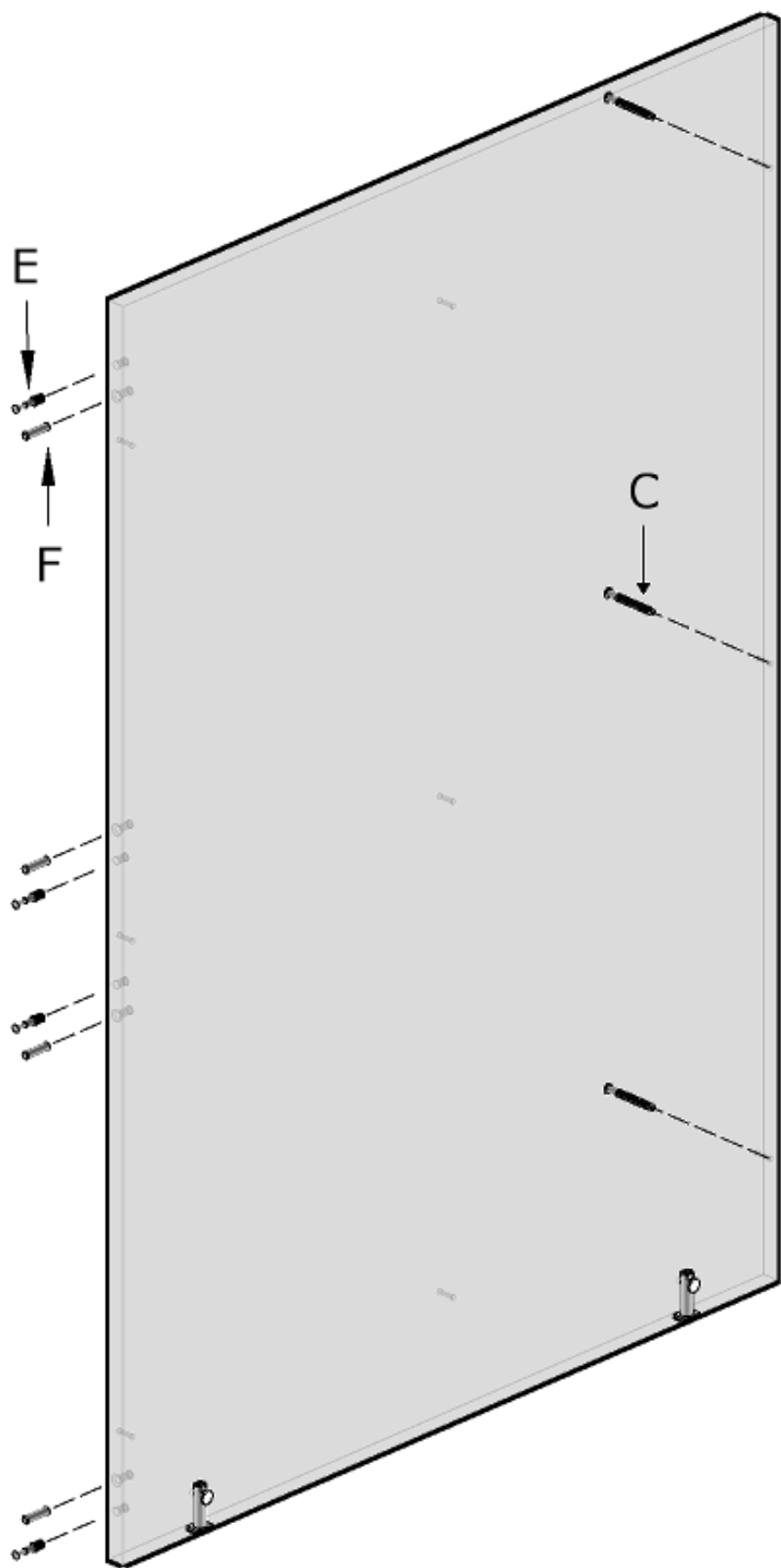

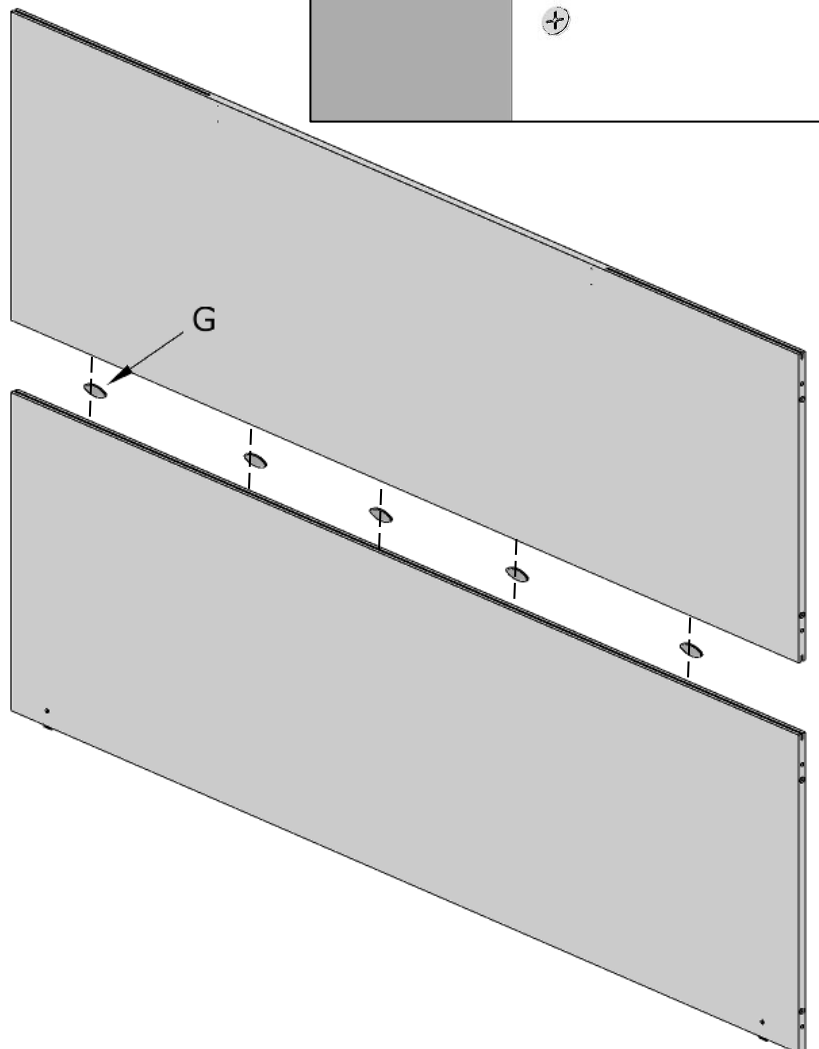
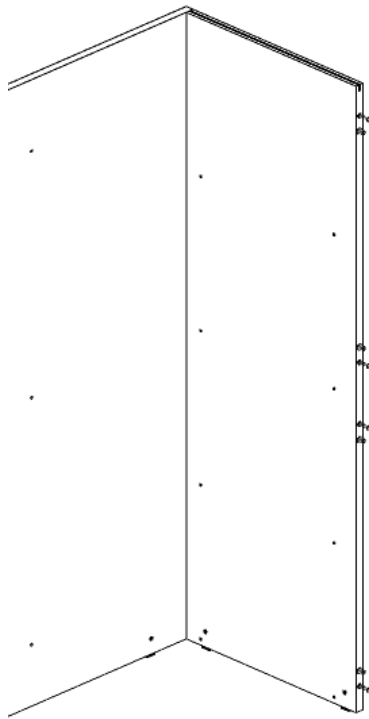
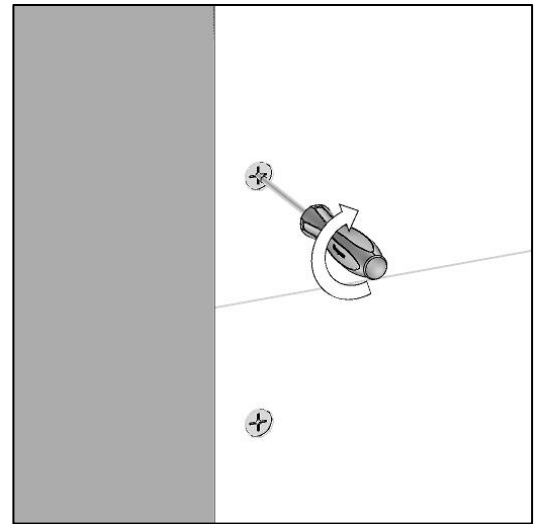
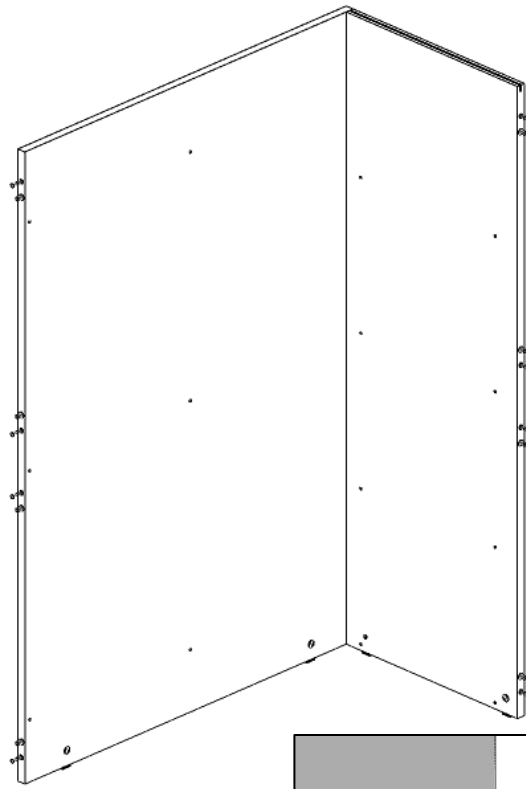
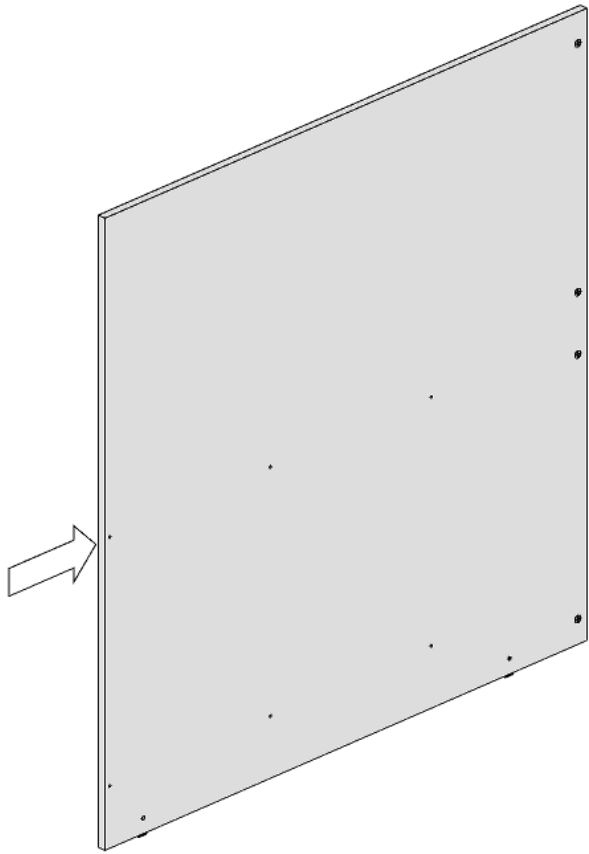

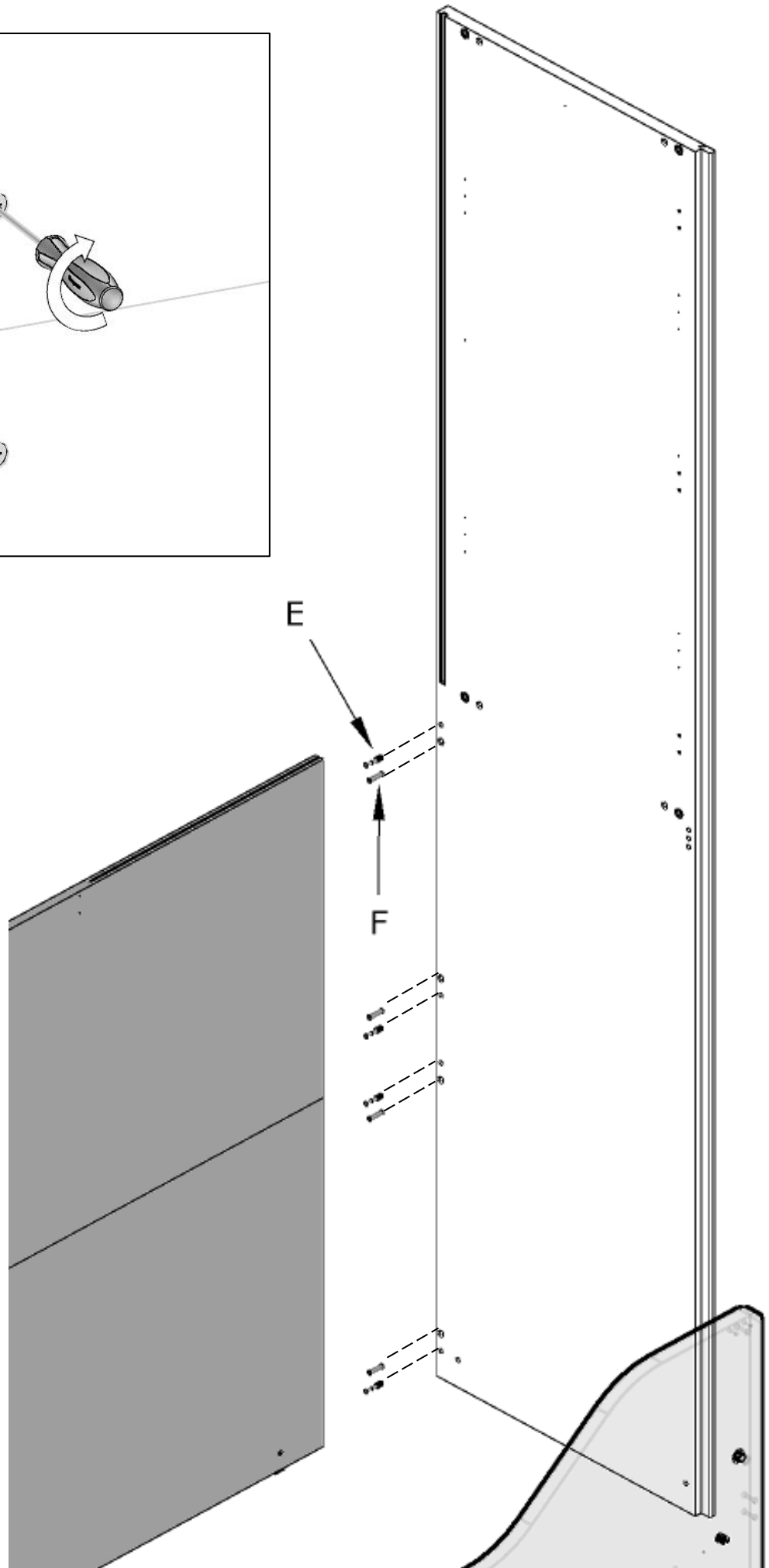
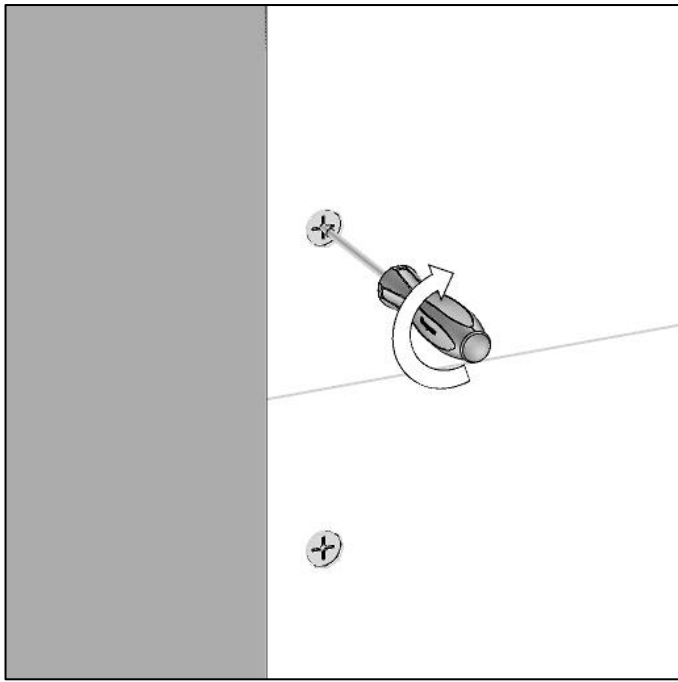

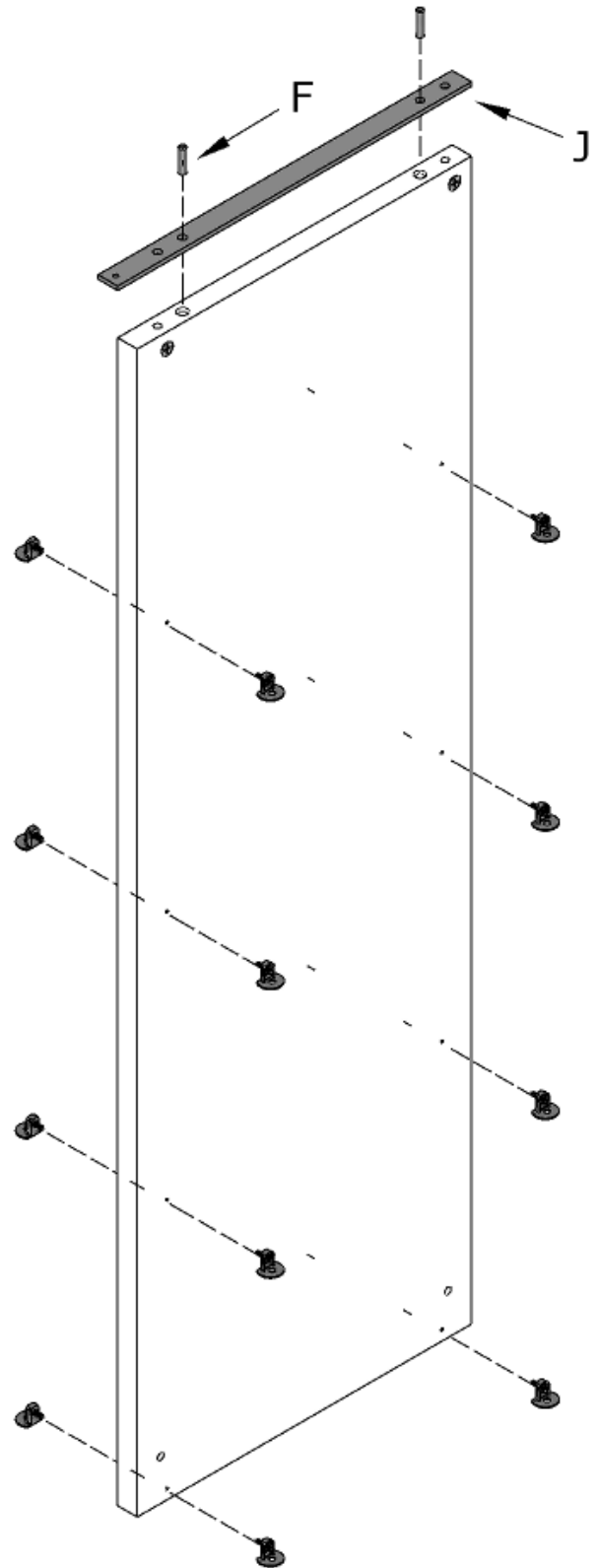
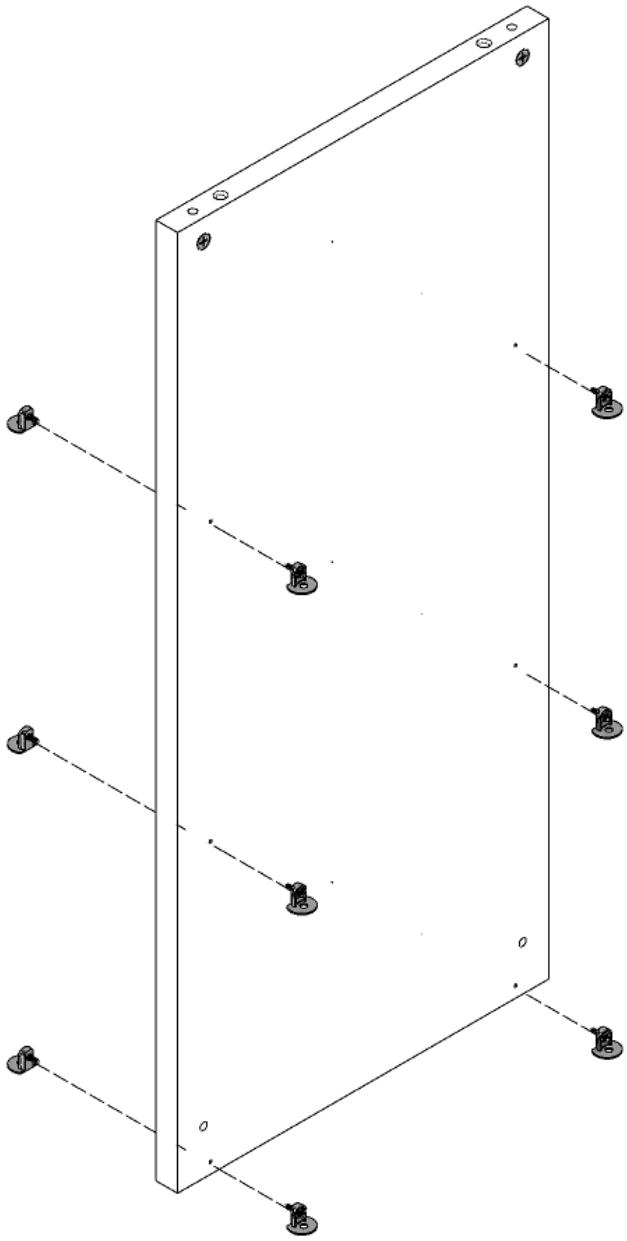

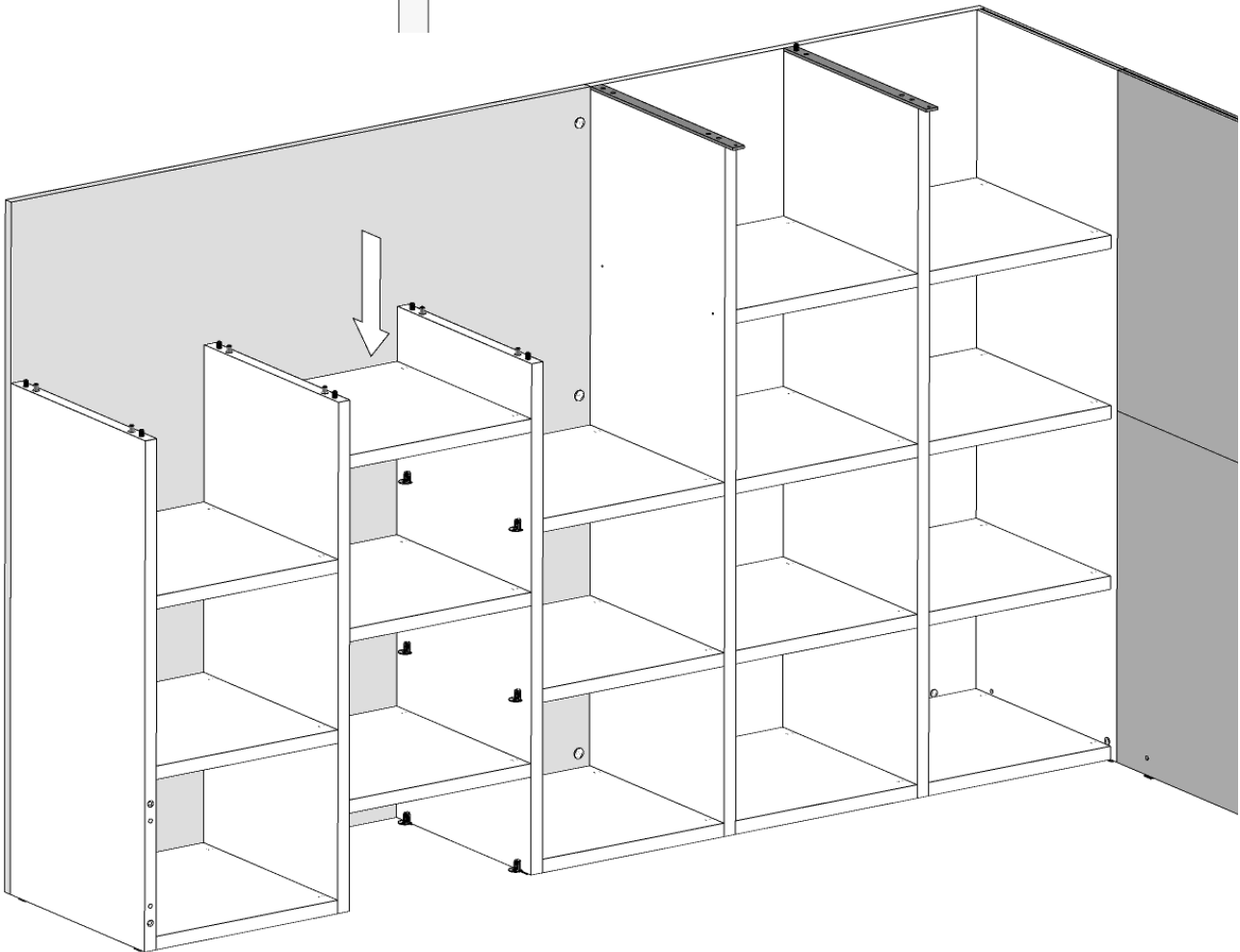
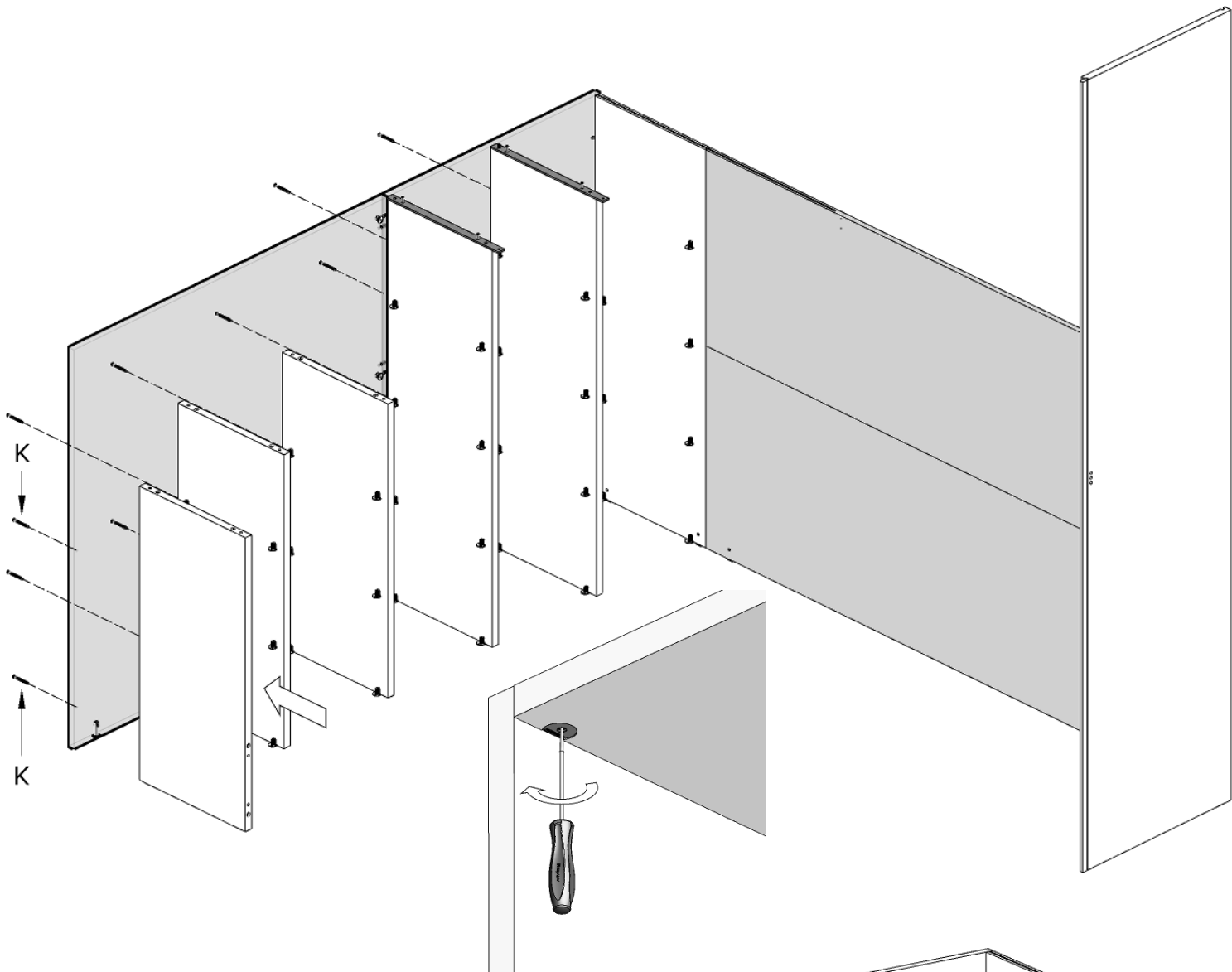

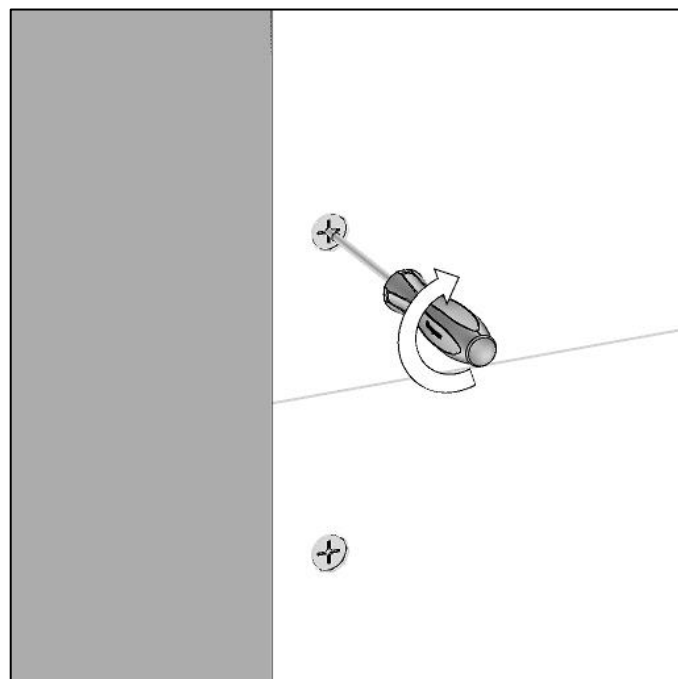
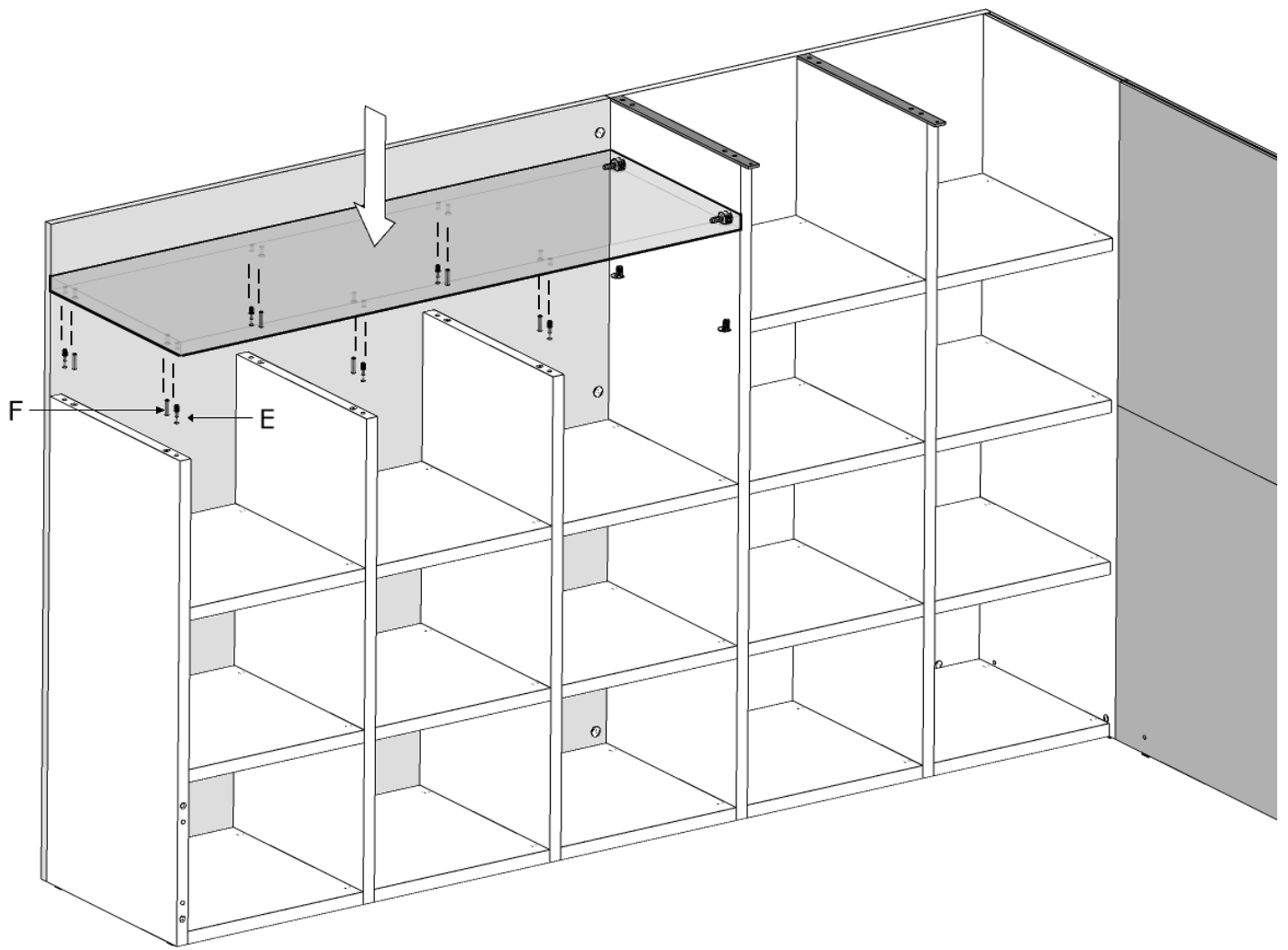



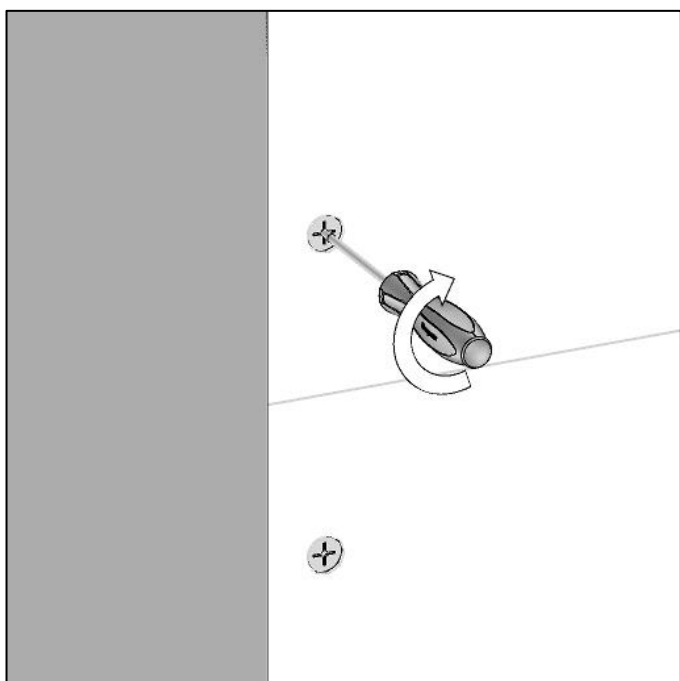
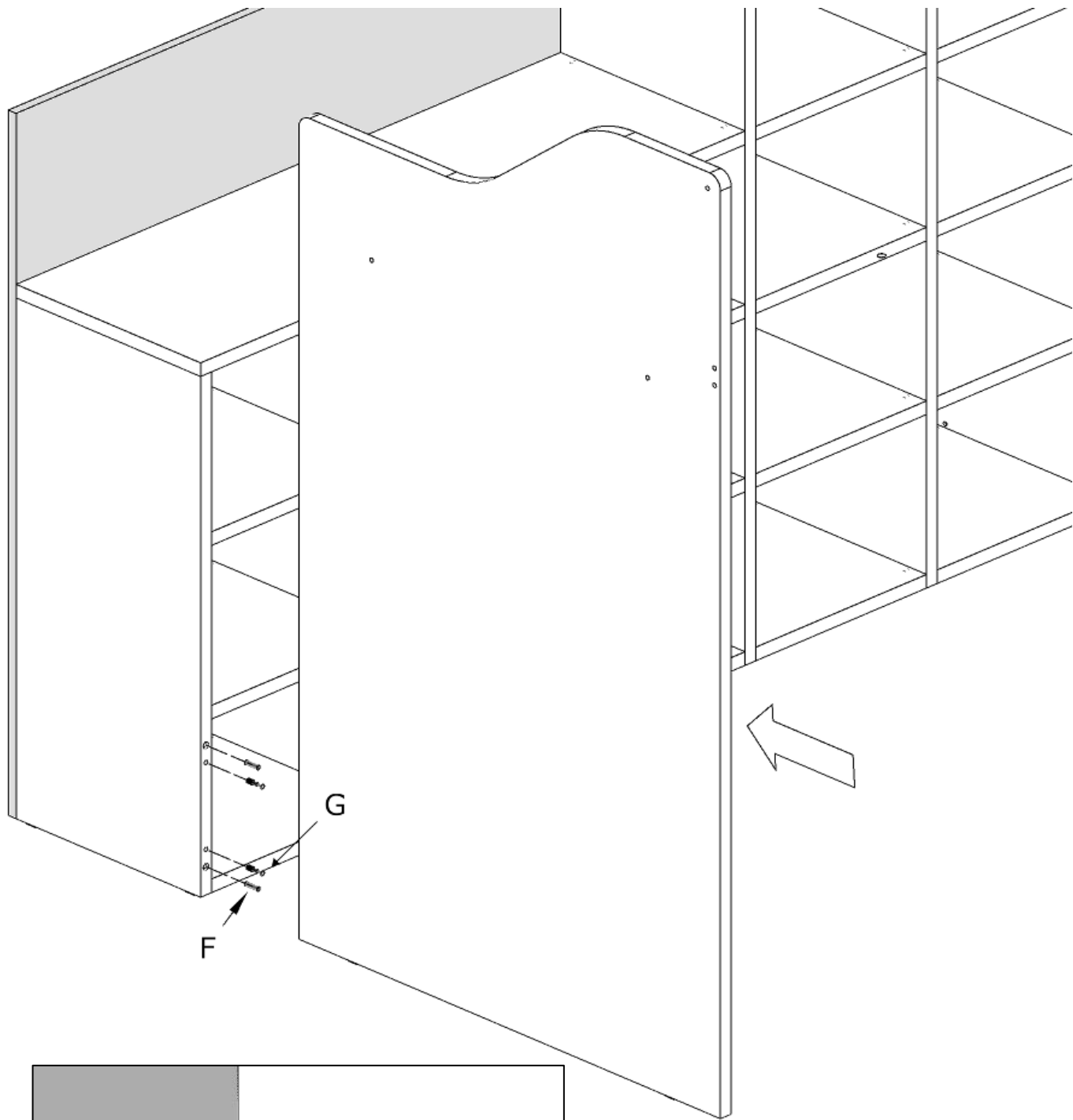

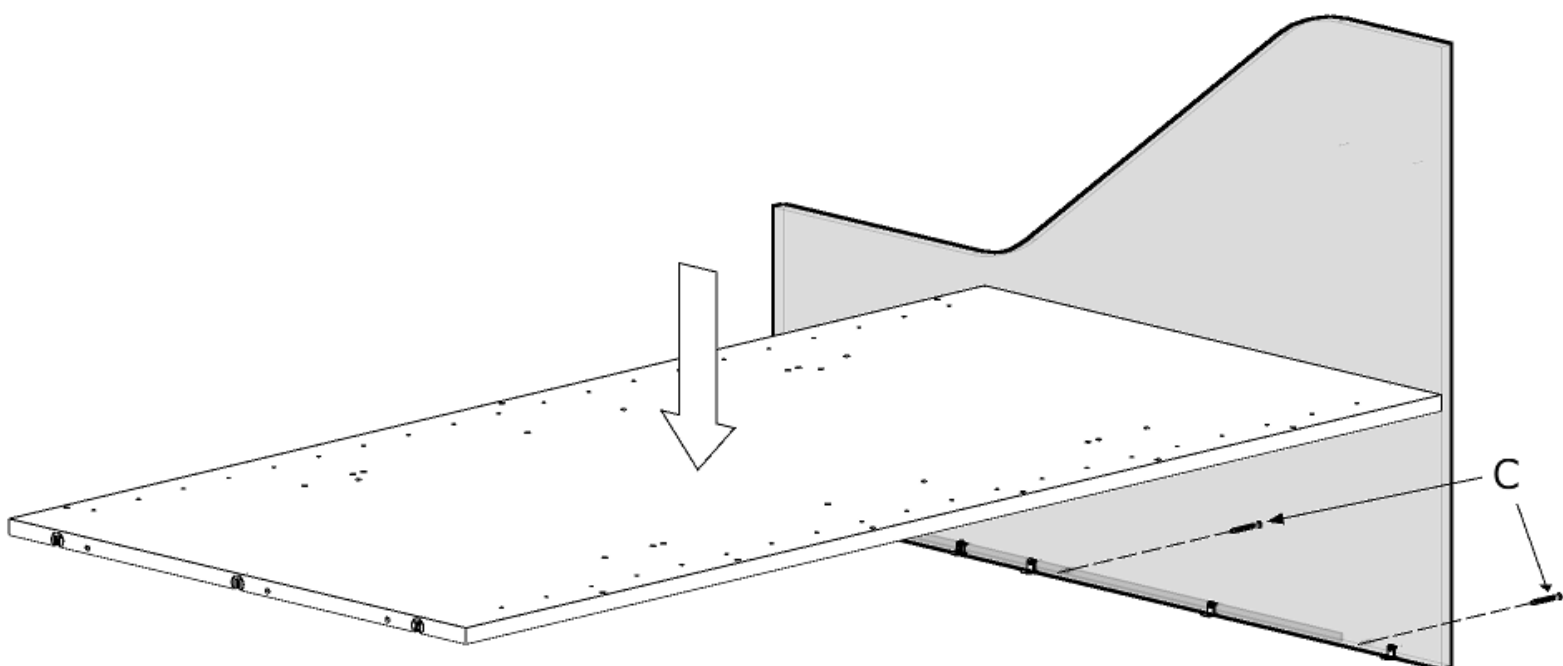
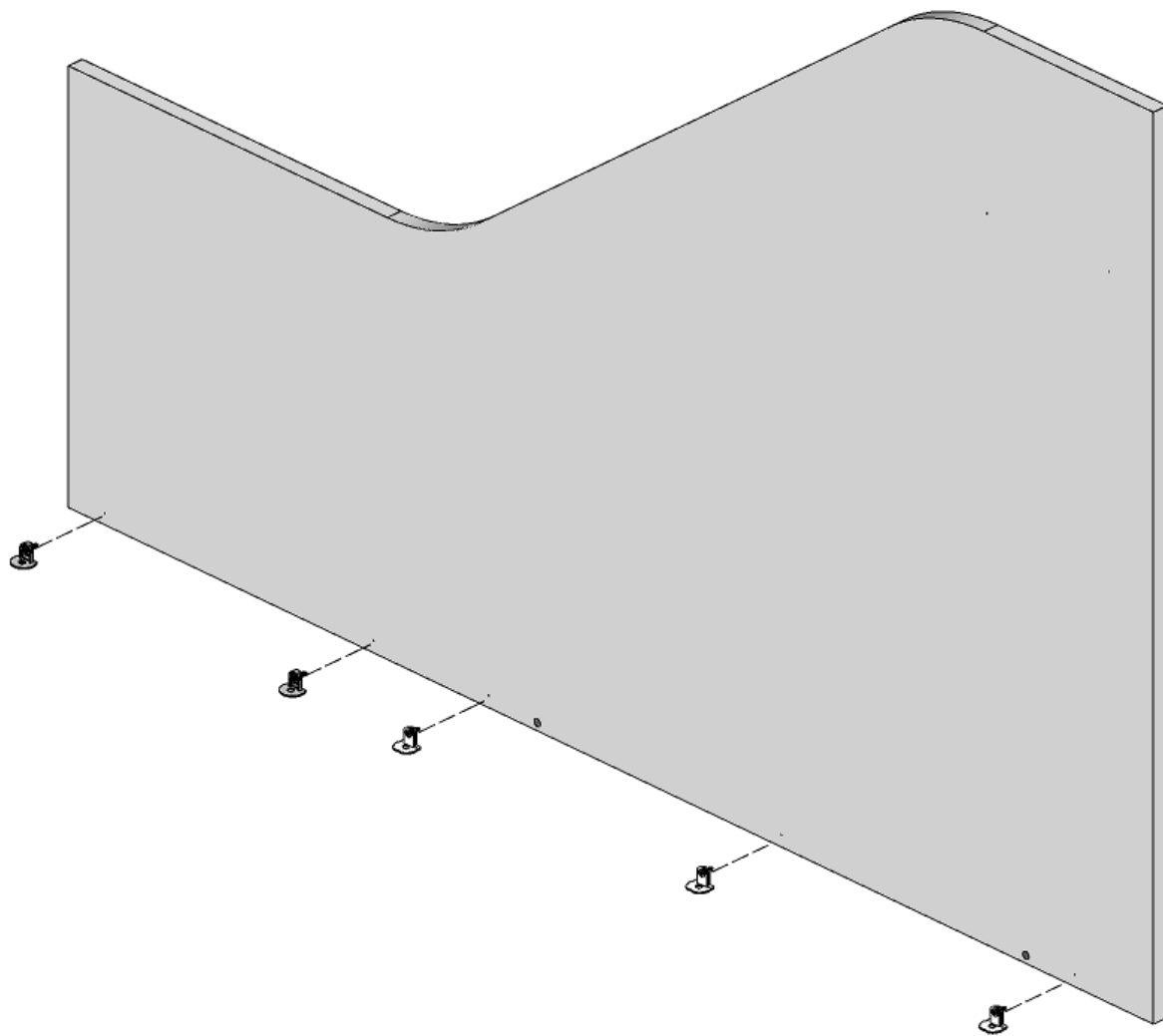

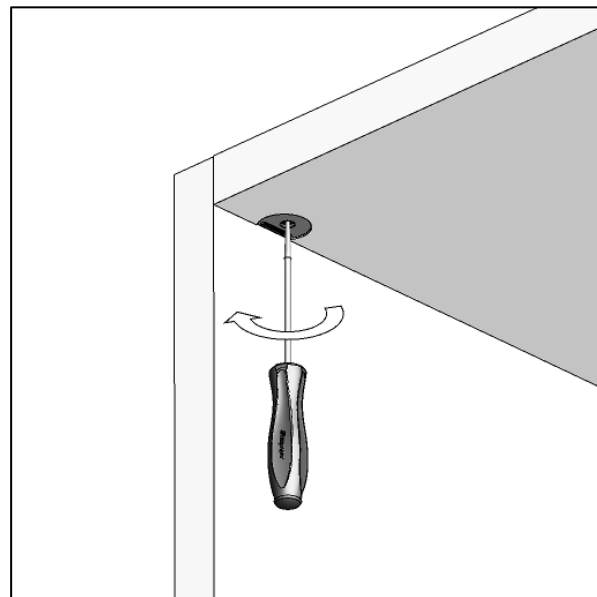
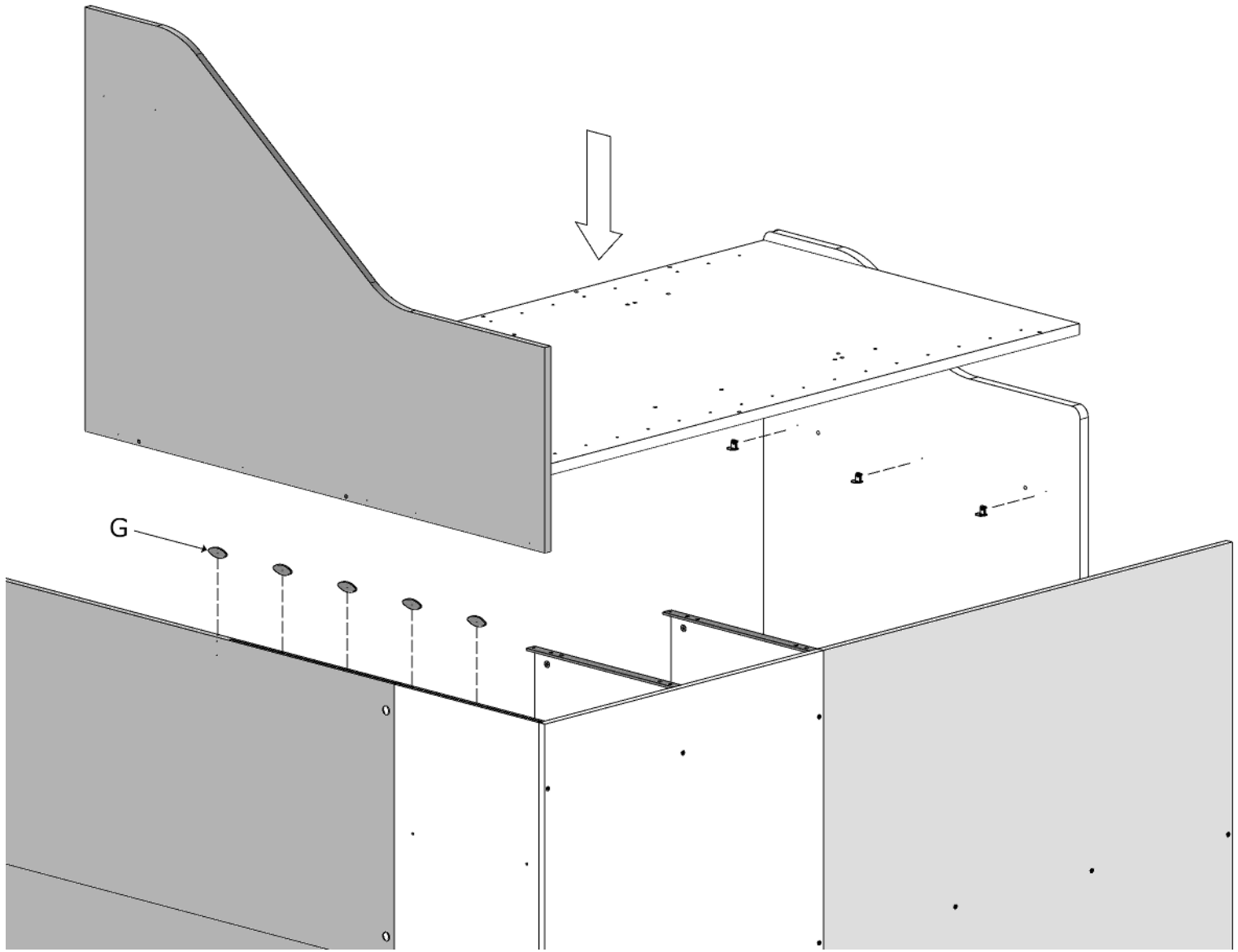

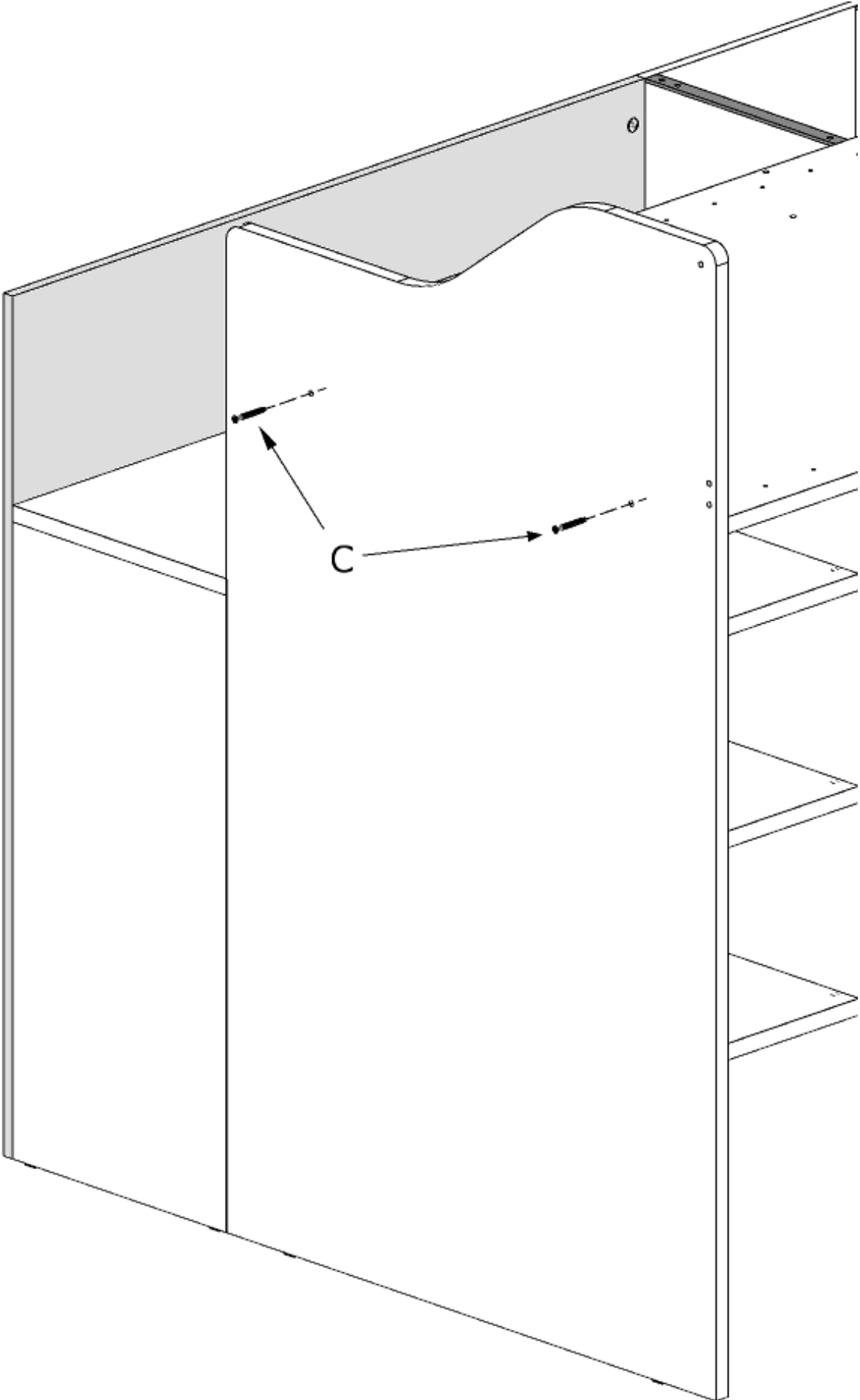

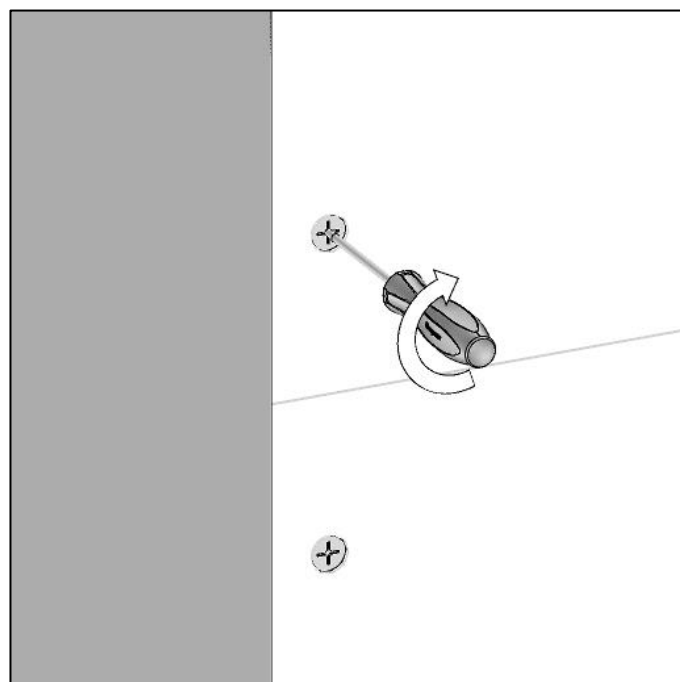
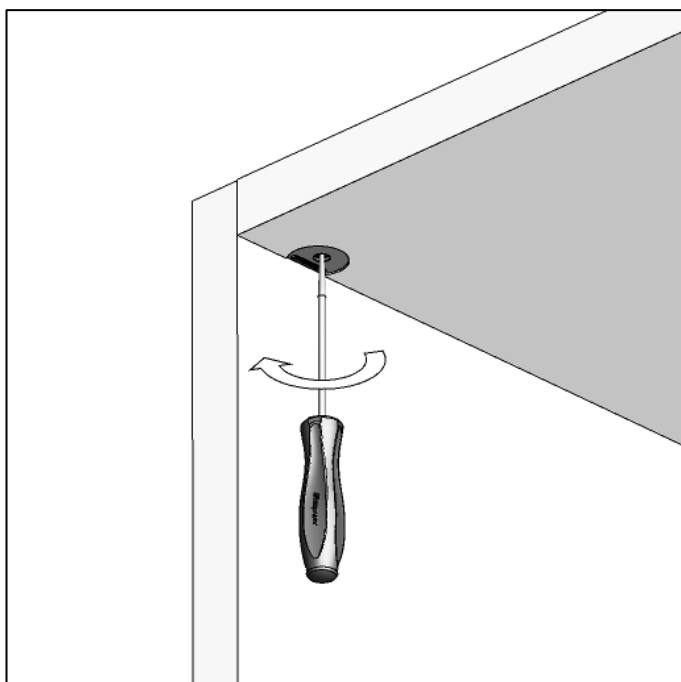
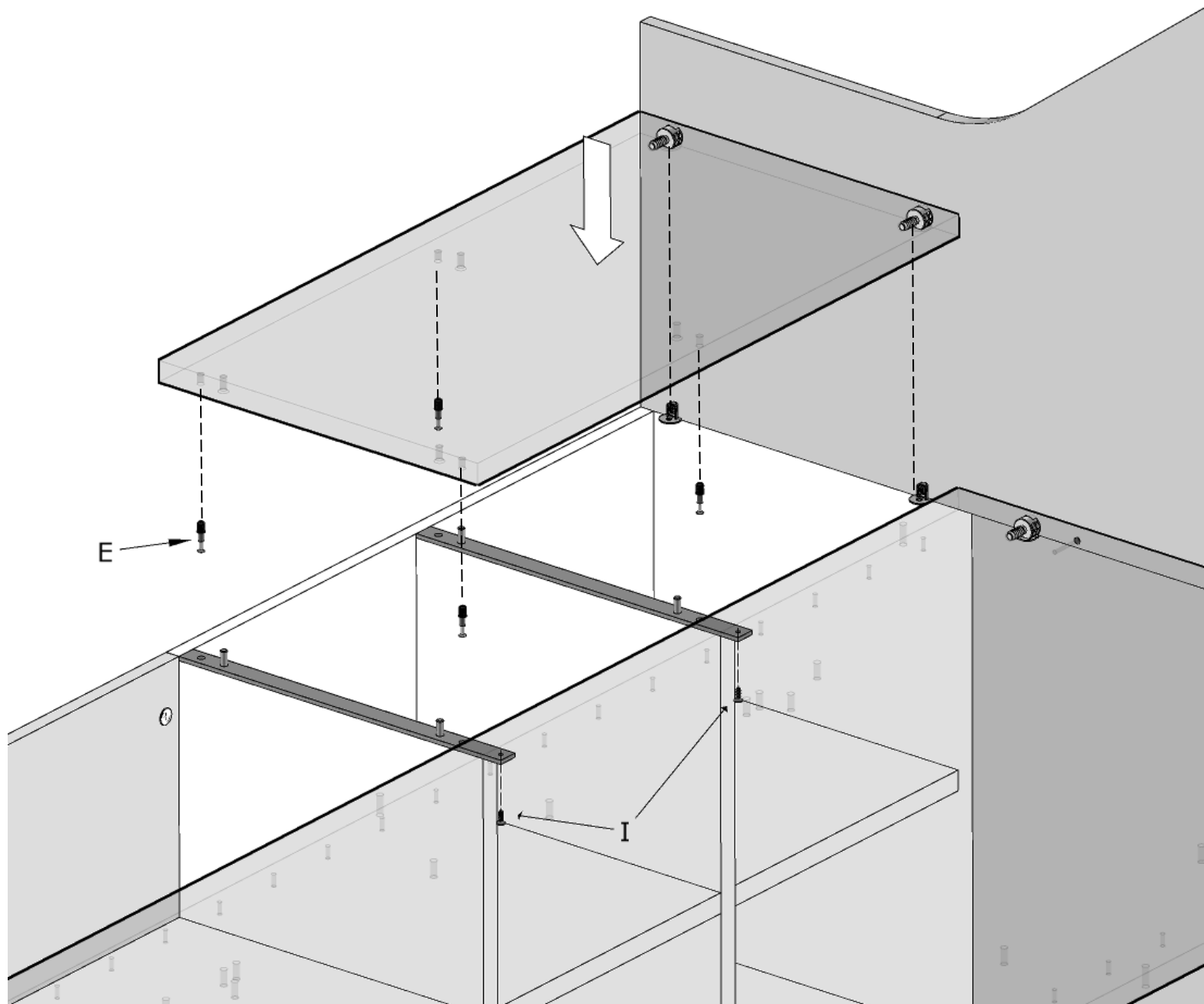

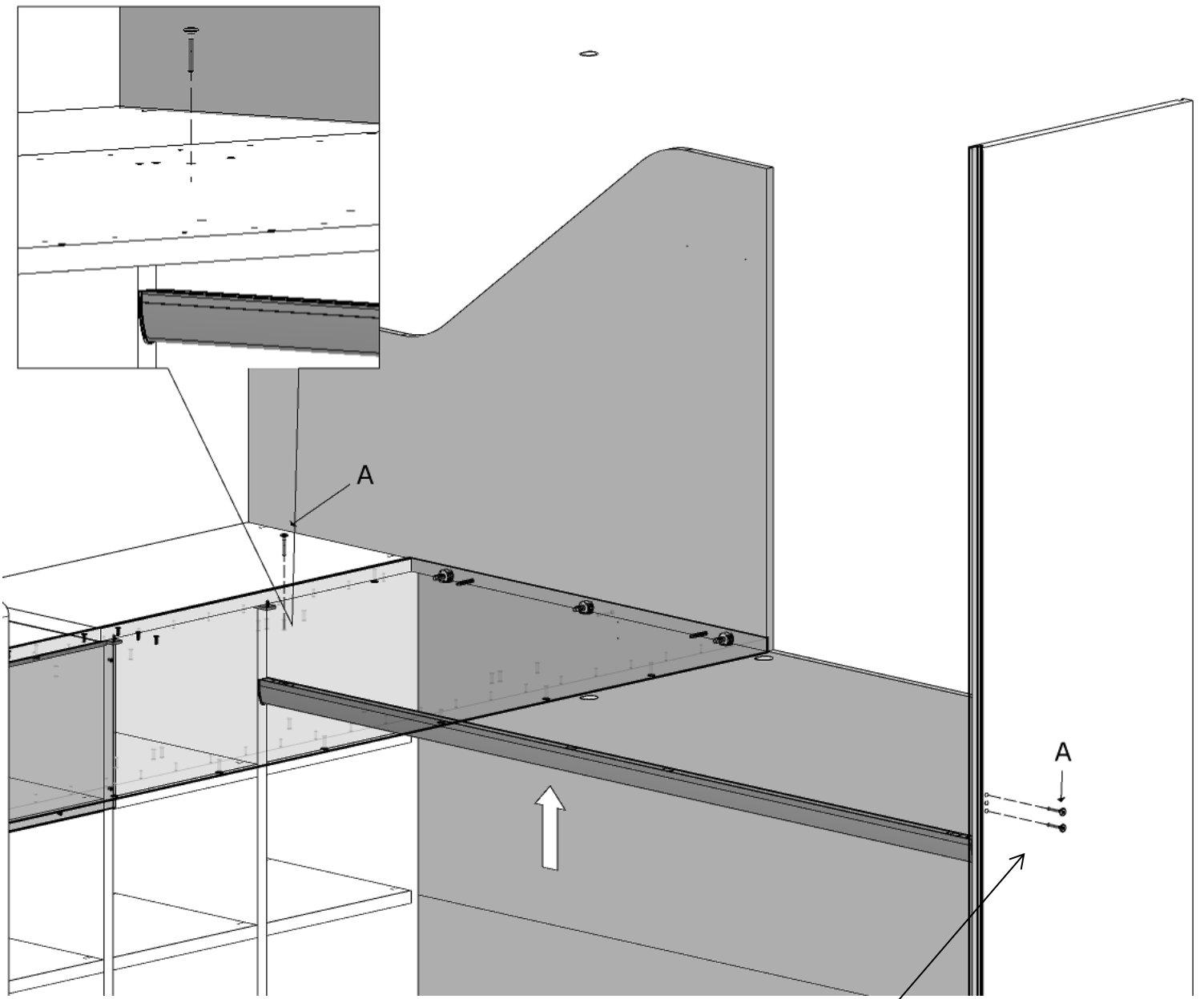

## IN PRESENZA DI MODULI AFFIANCATI

Sostituire la vite "A" (solo quella che crea conflitto con il modulo affiancato)  
con la vite "L" come da disegno

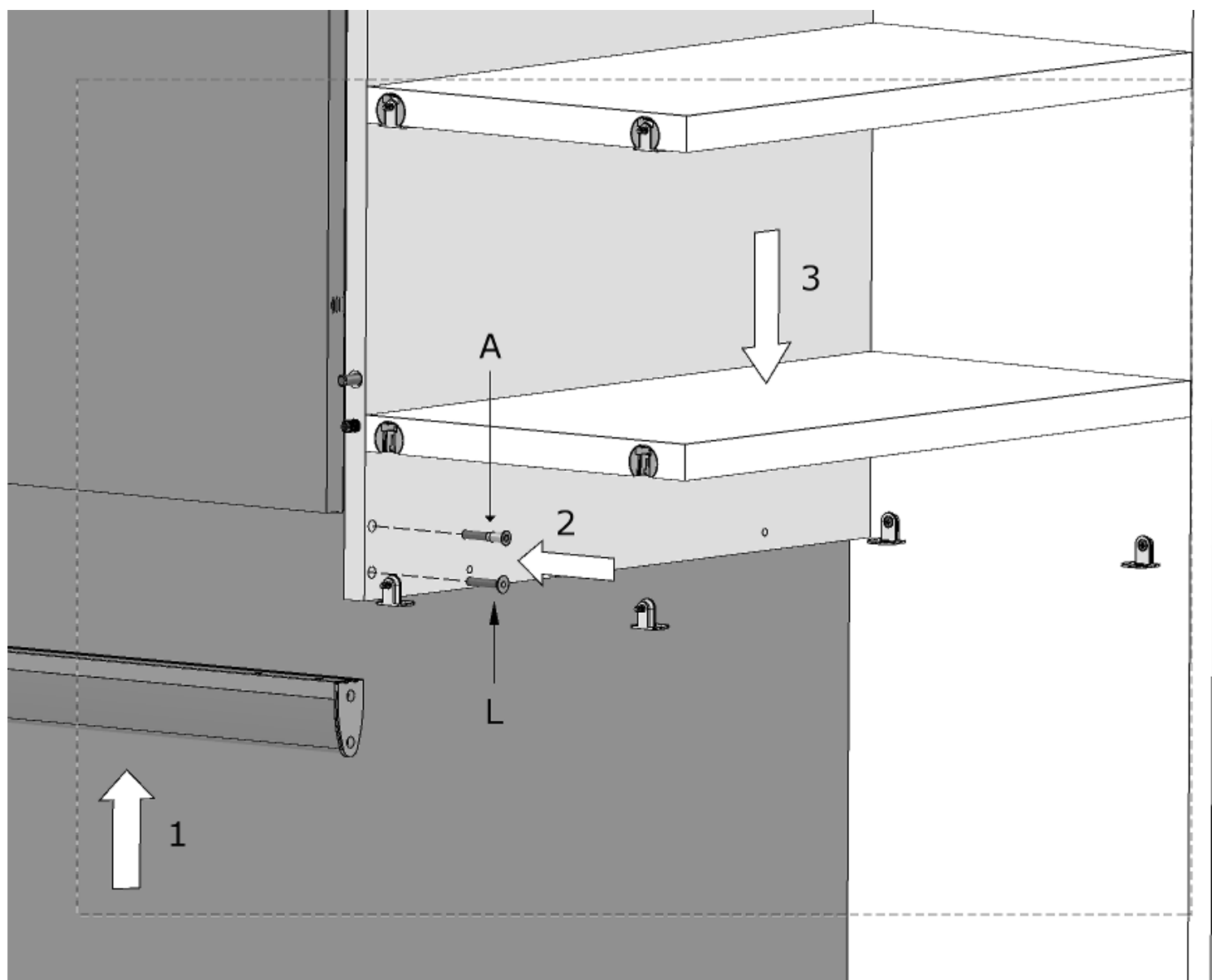

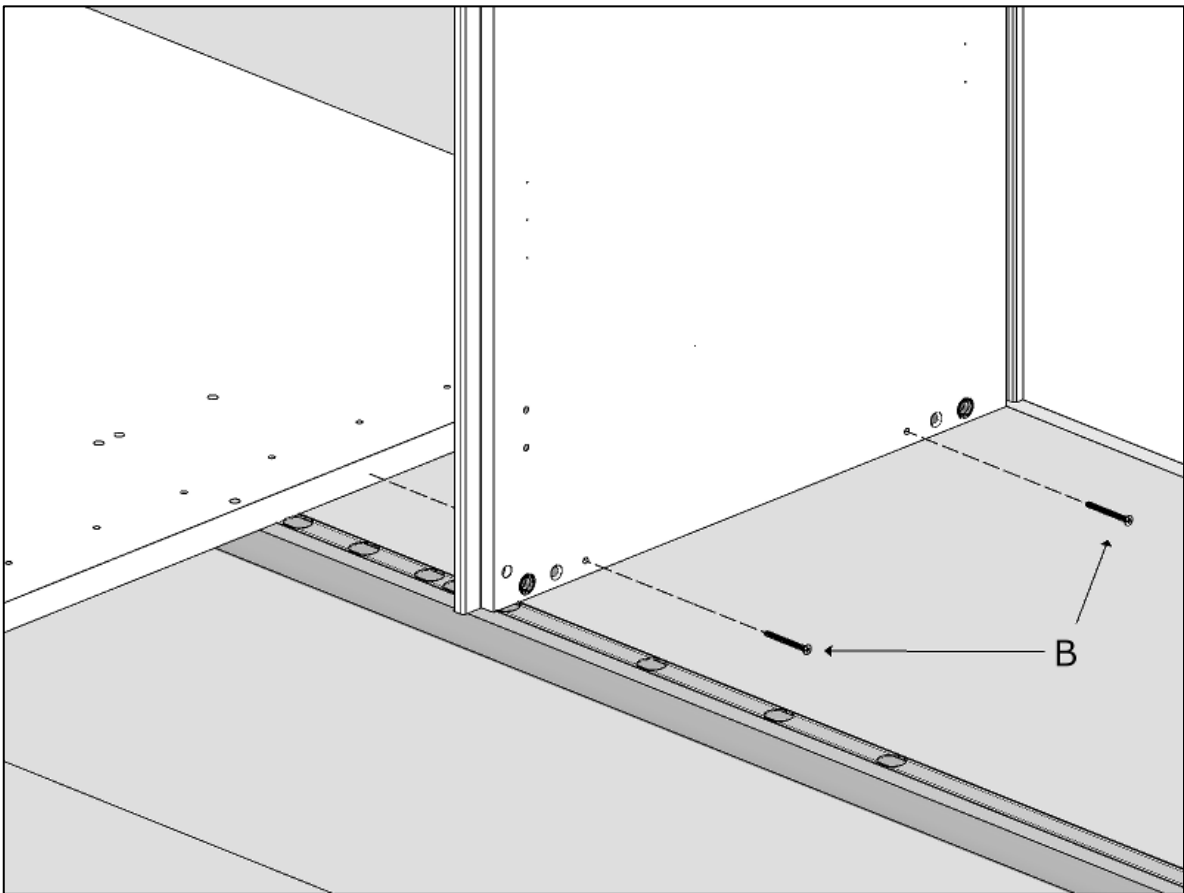
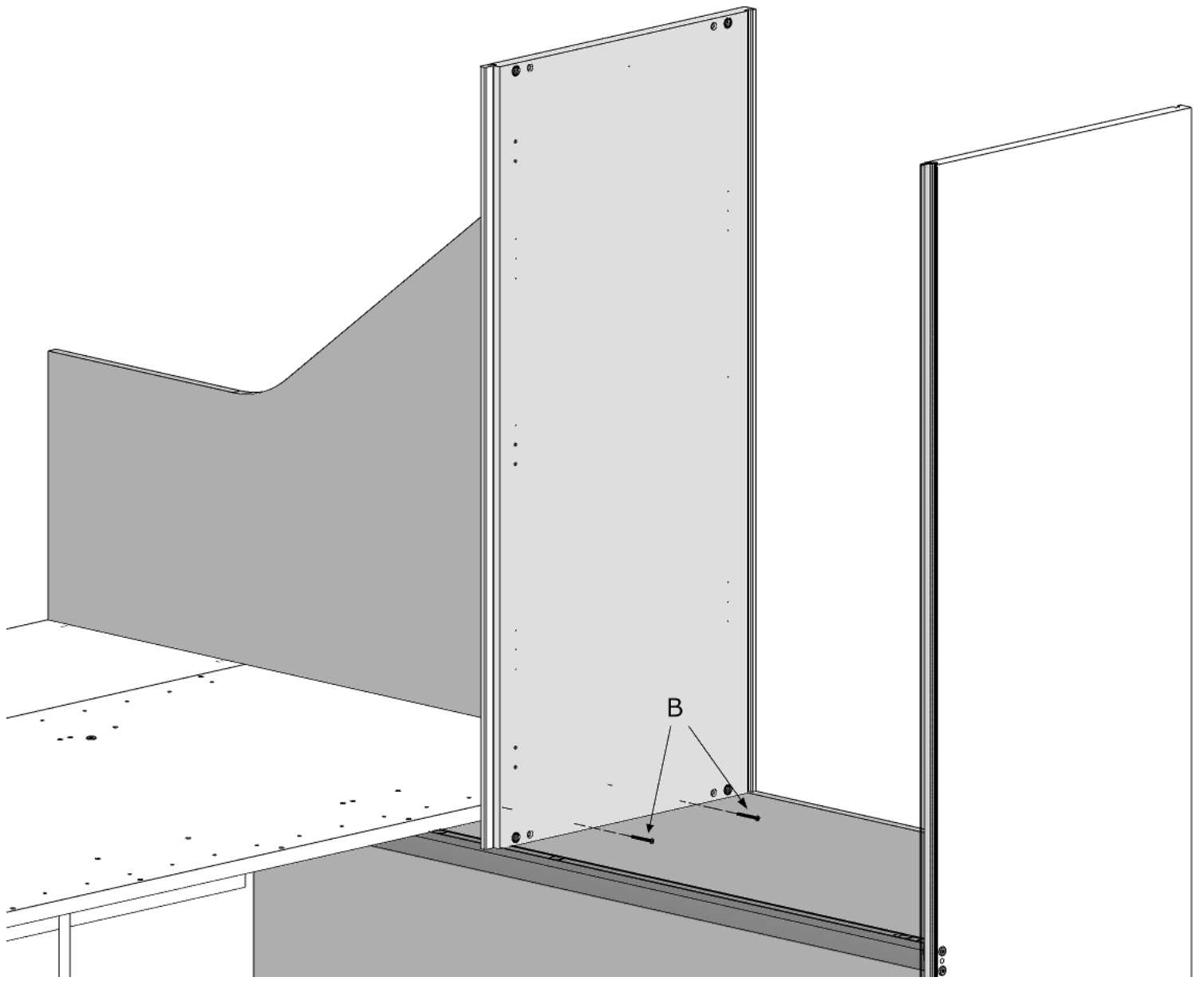



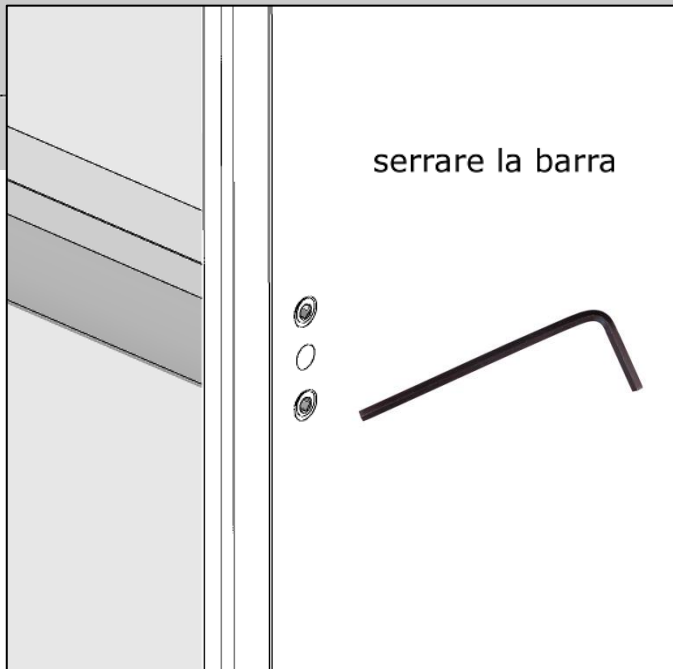
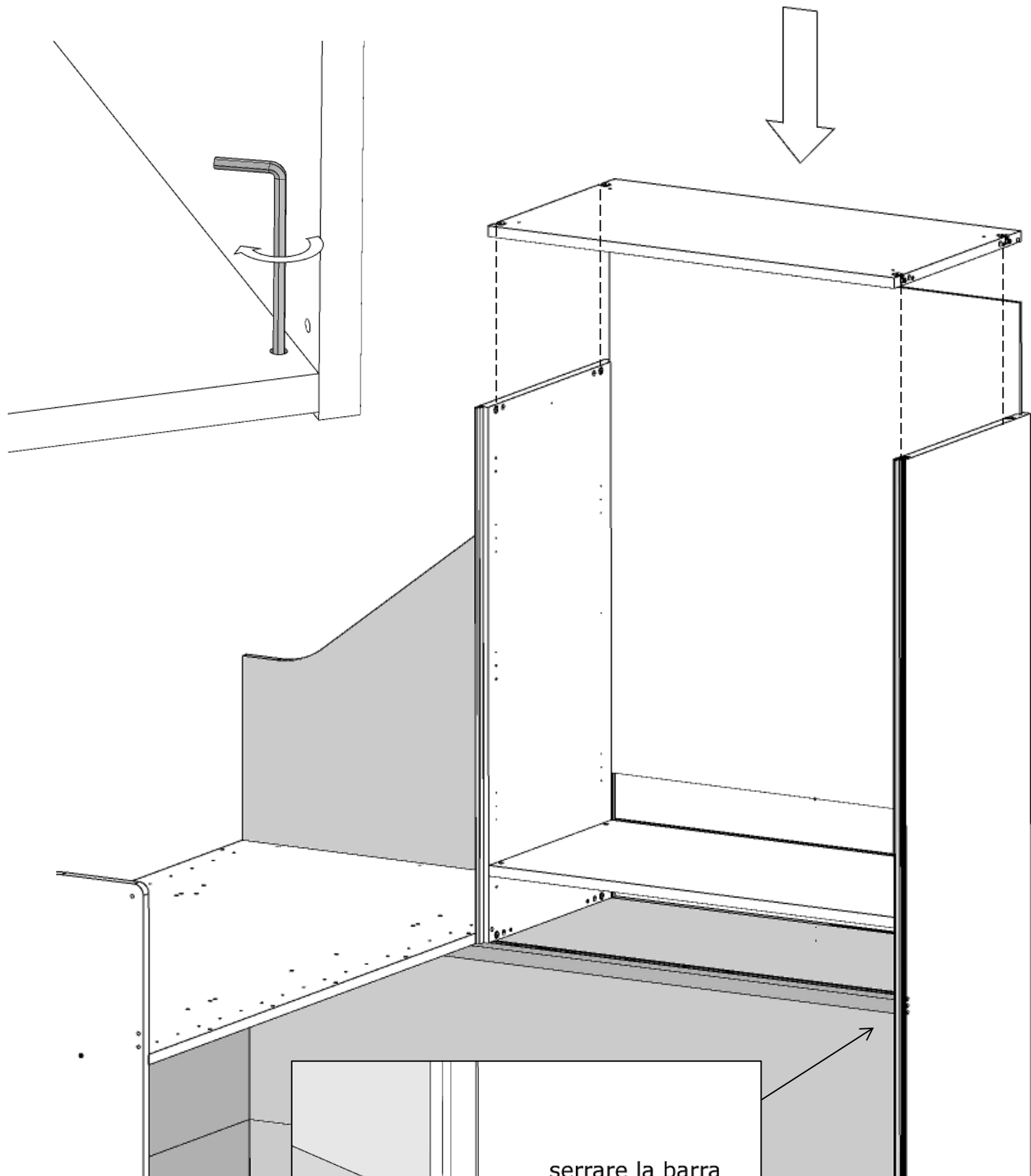

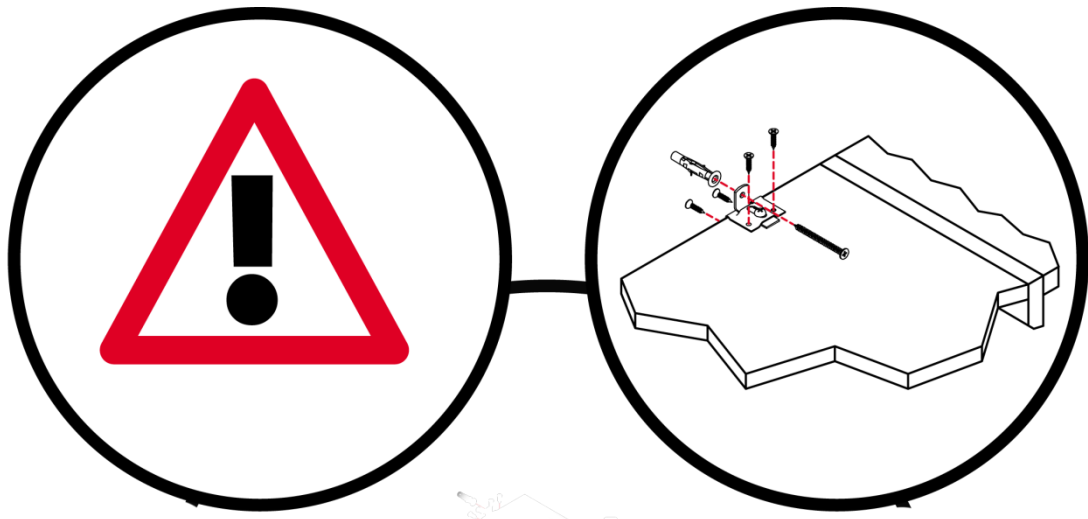

**ATTENZIONE!**  
**OBBLIGATORIO ANCORAGGIO A MURO**

**WARNING!**  
**WALL ANCHORING STRICTLY NEEDED**

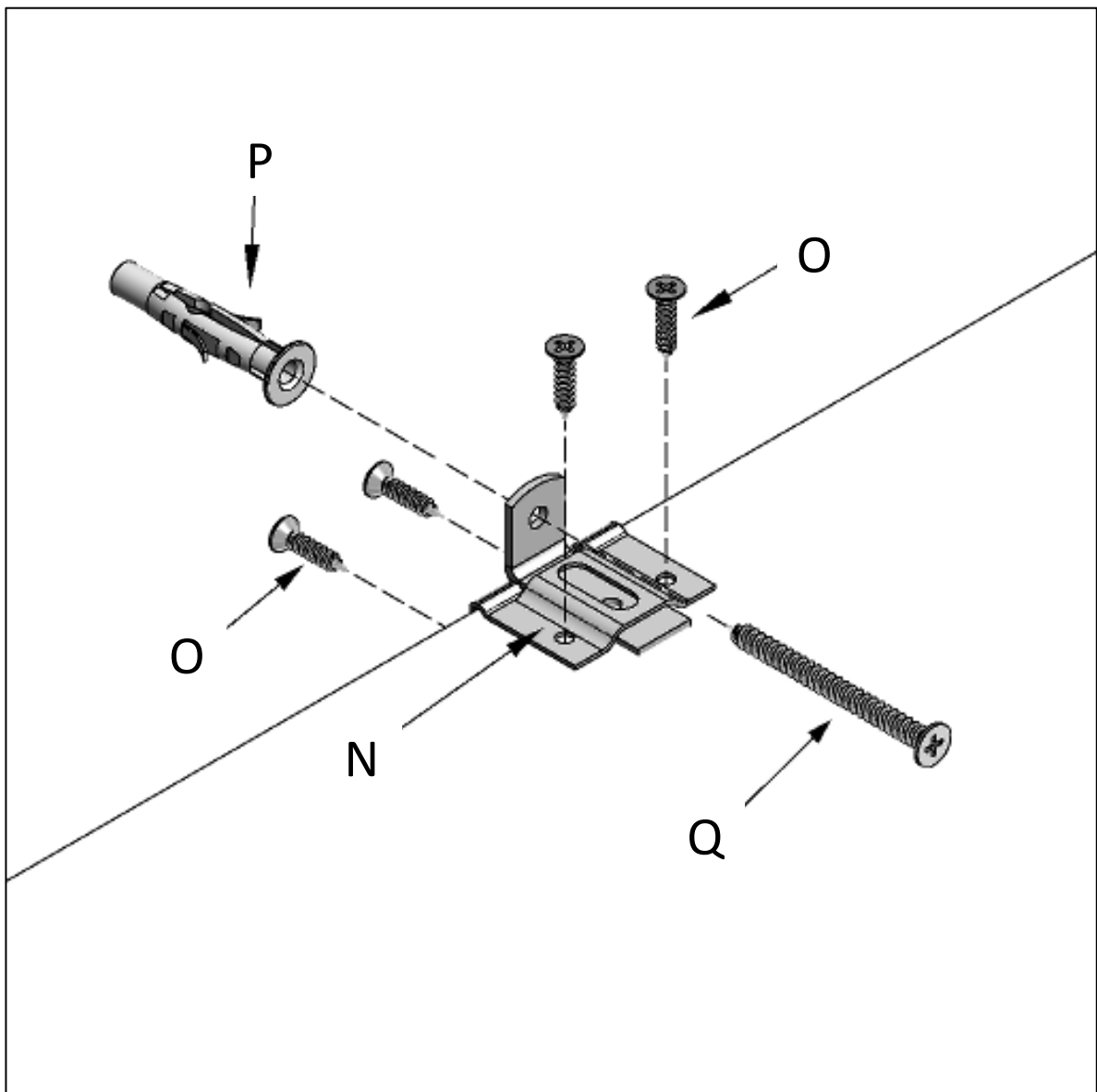

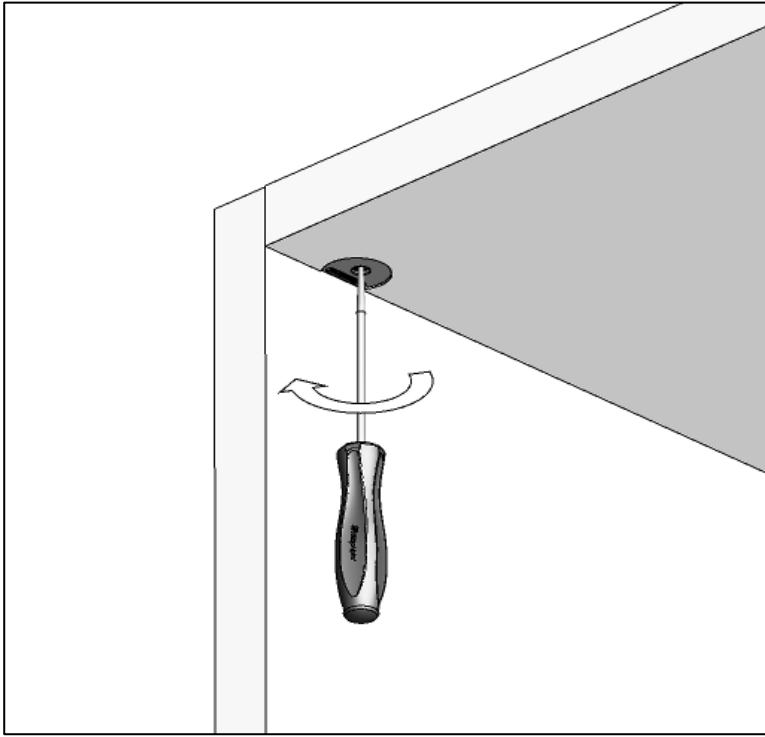



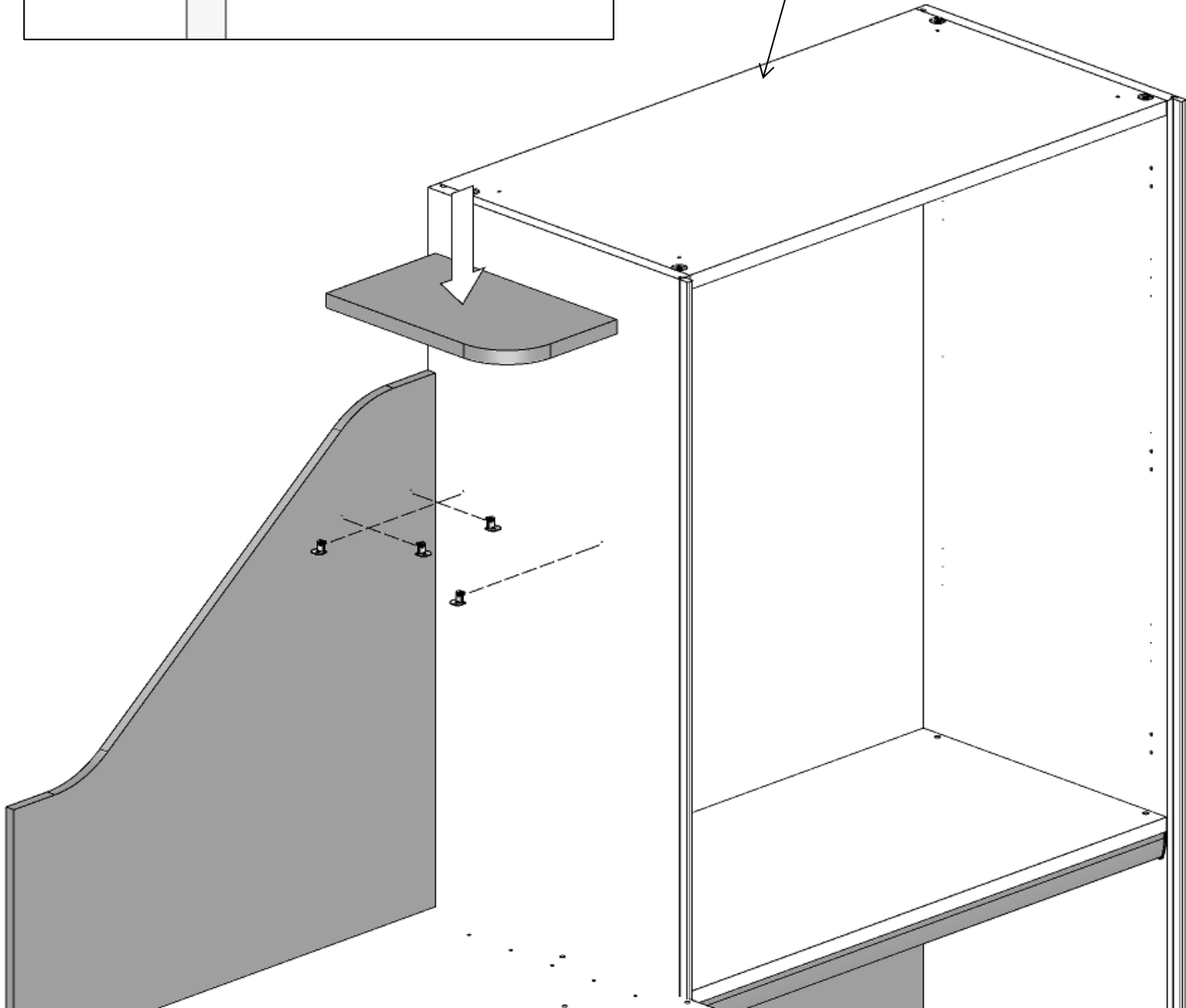

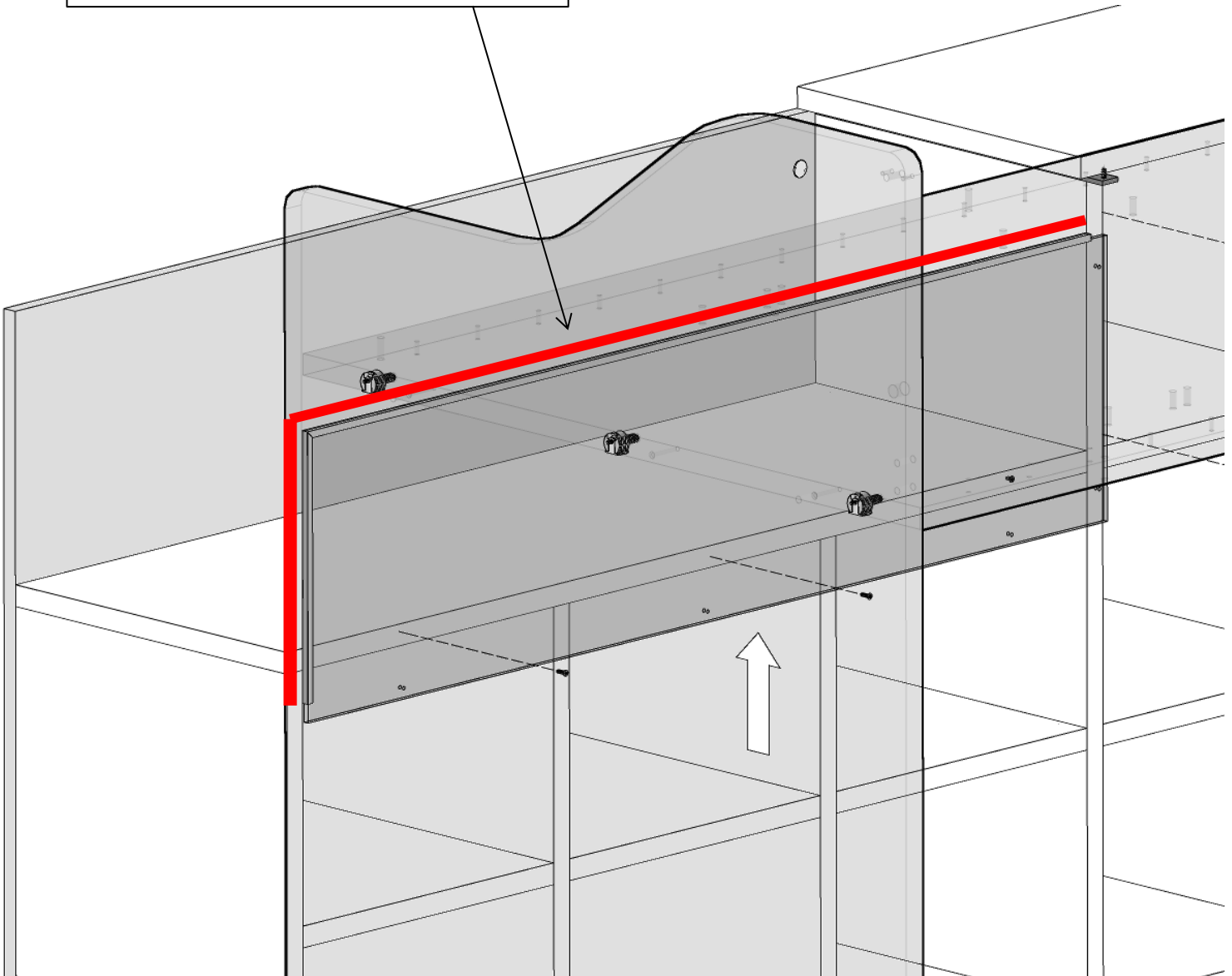

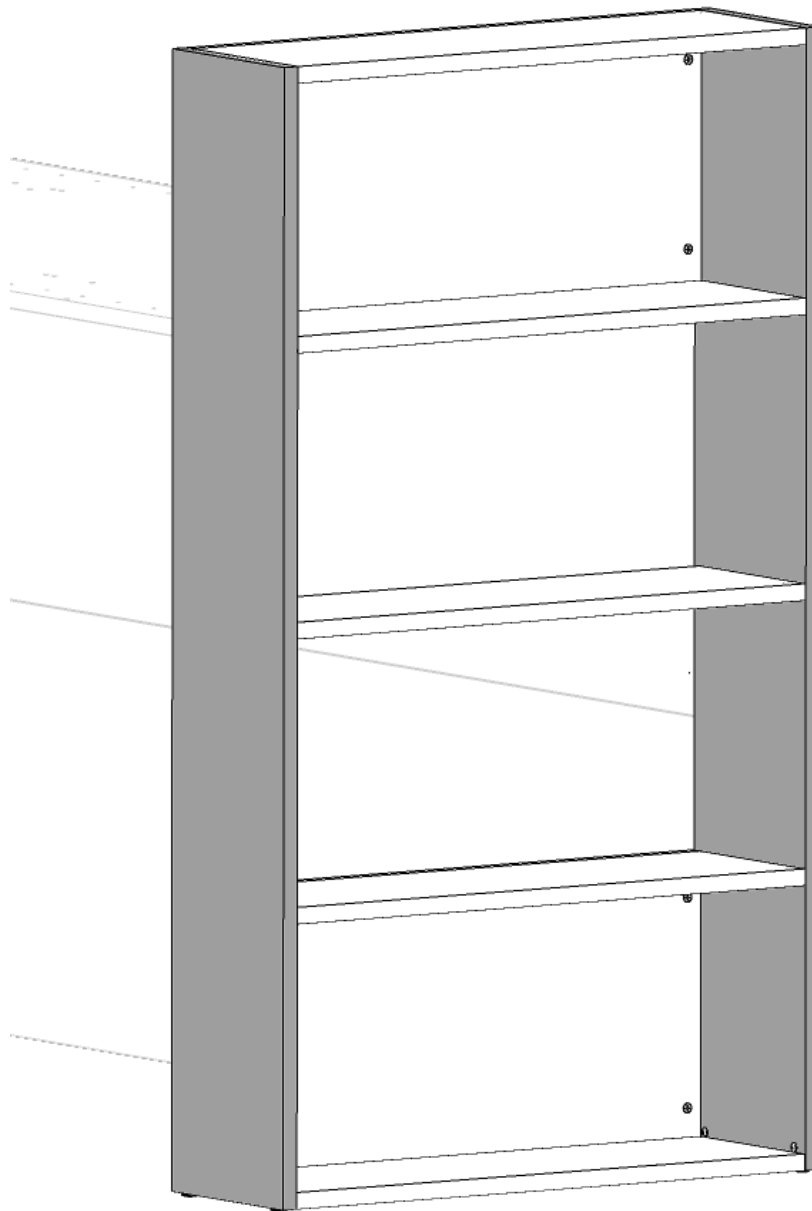
ANCORAGGIO  
A MURO





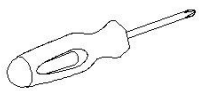

**080005824 - SFR\_Sac.Fr.Fianco Sop.Libreria**

200000666	A		n°8	
200000653	B		n°8	
200000962	C		n°4	

**REGGIRIPIANO LIBRERIA**

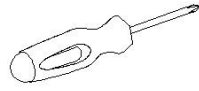
	E		n°20	
--	---	---	------	---

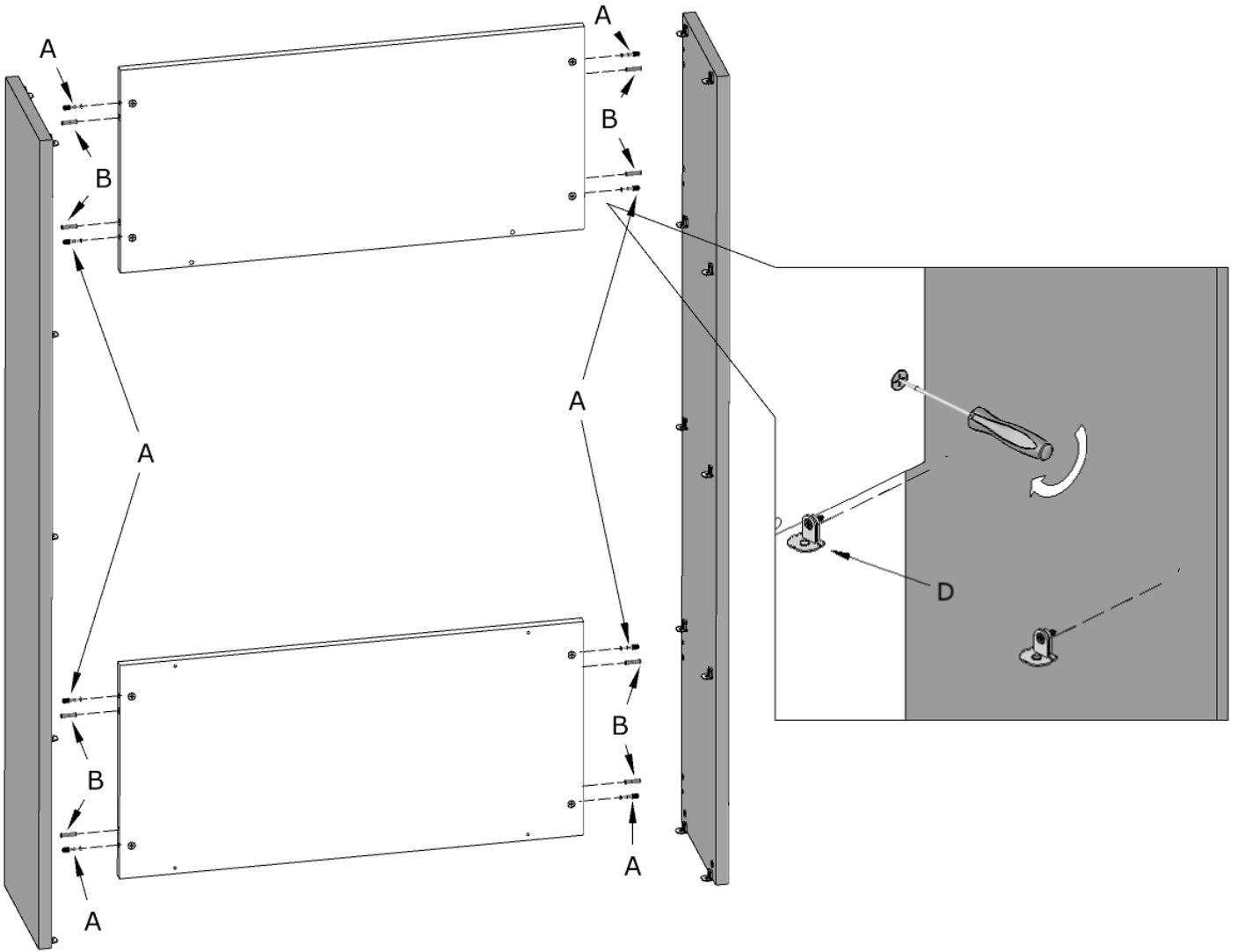

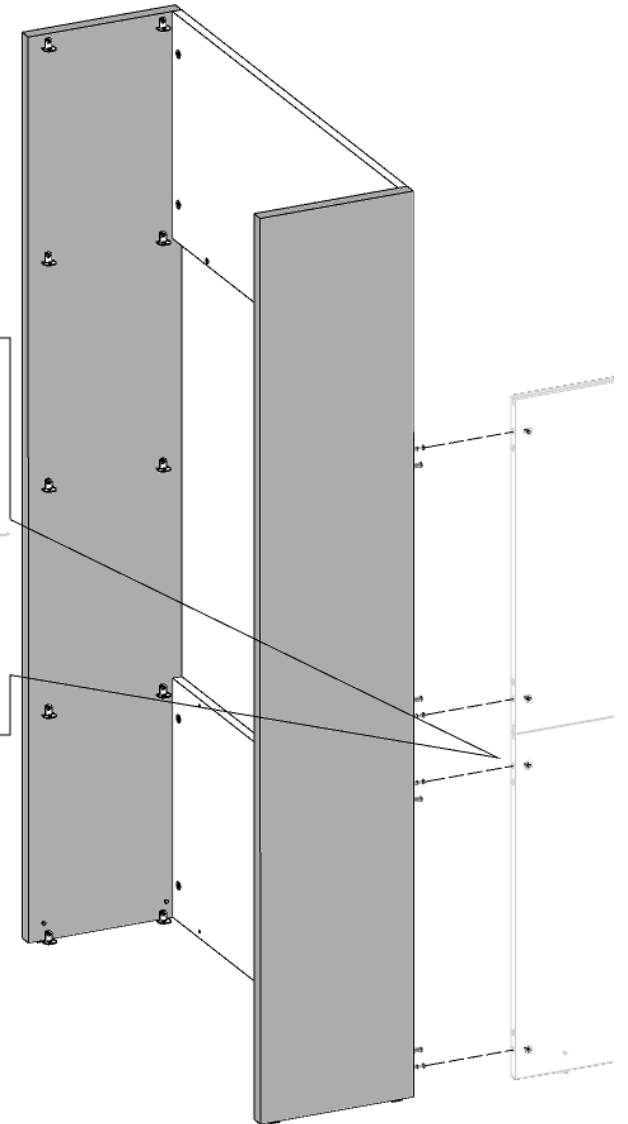
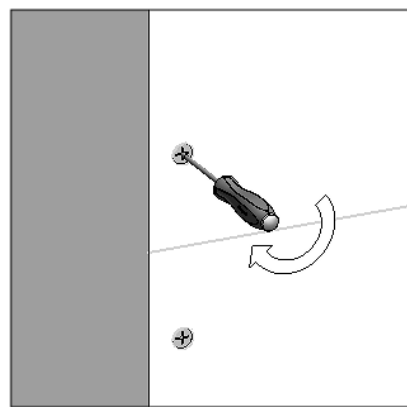
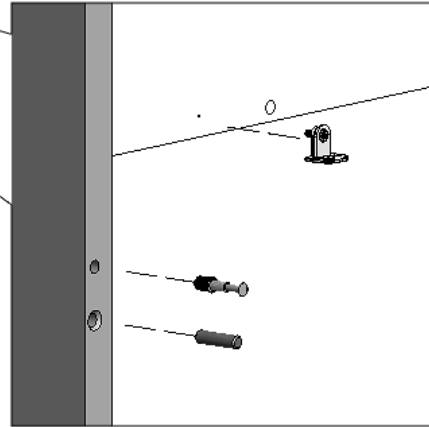
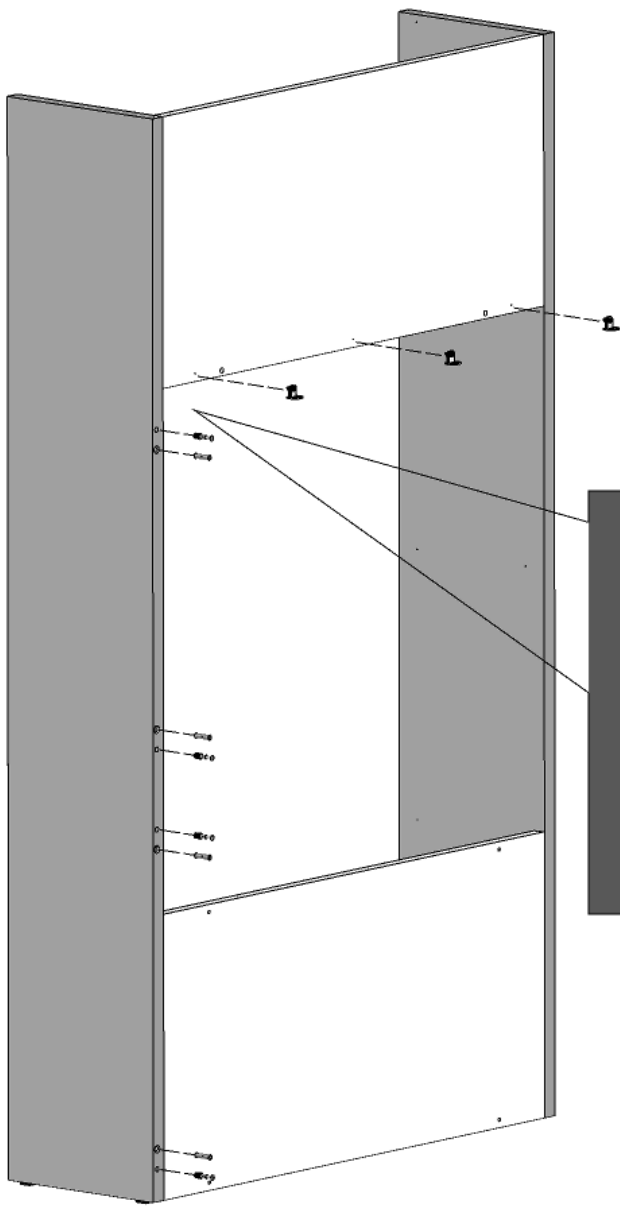

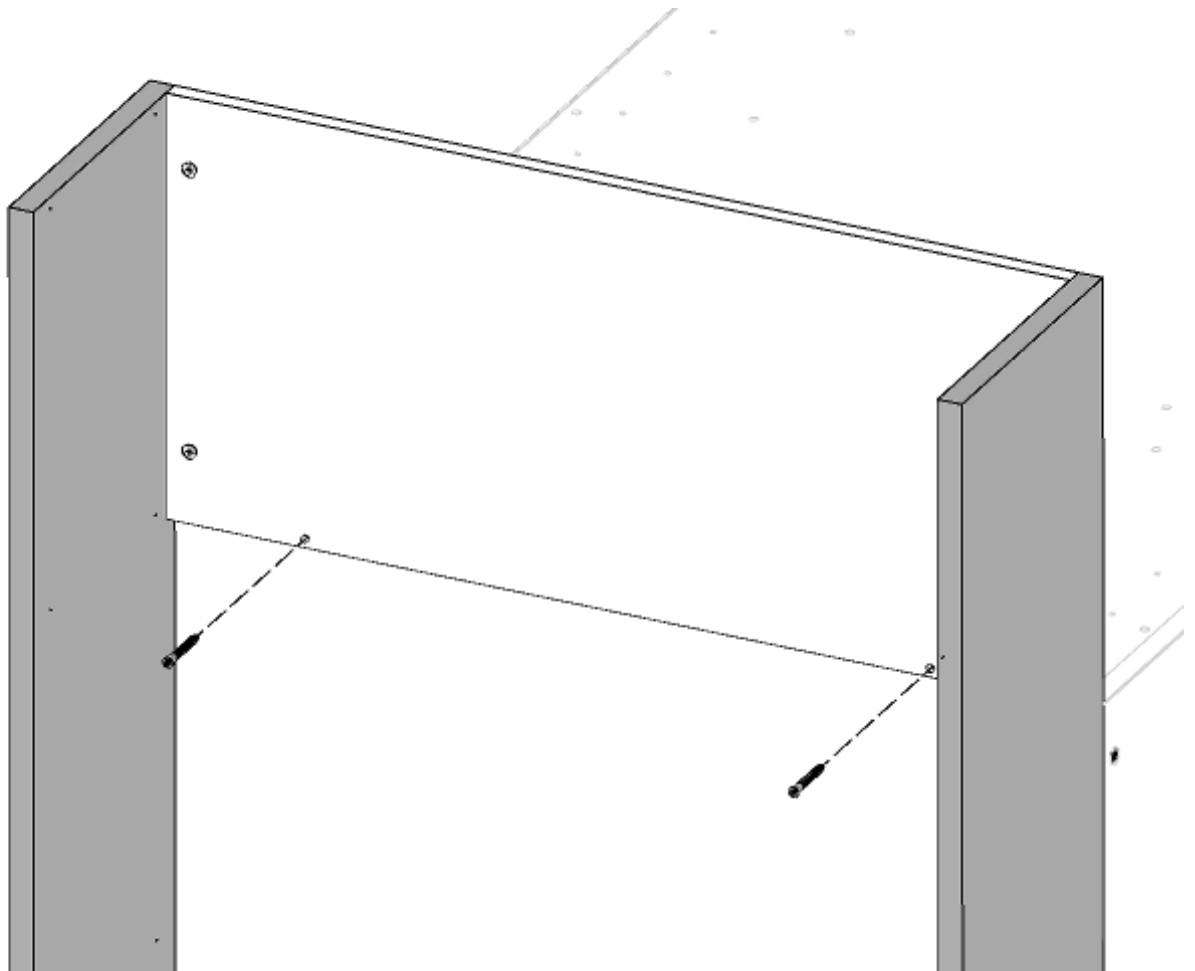
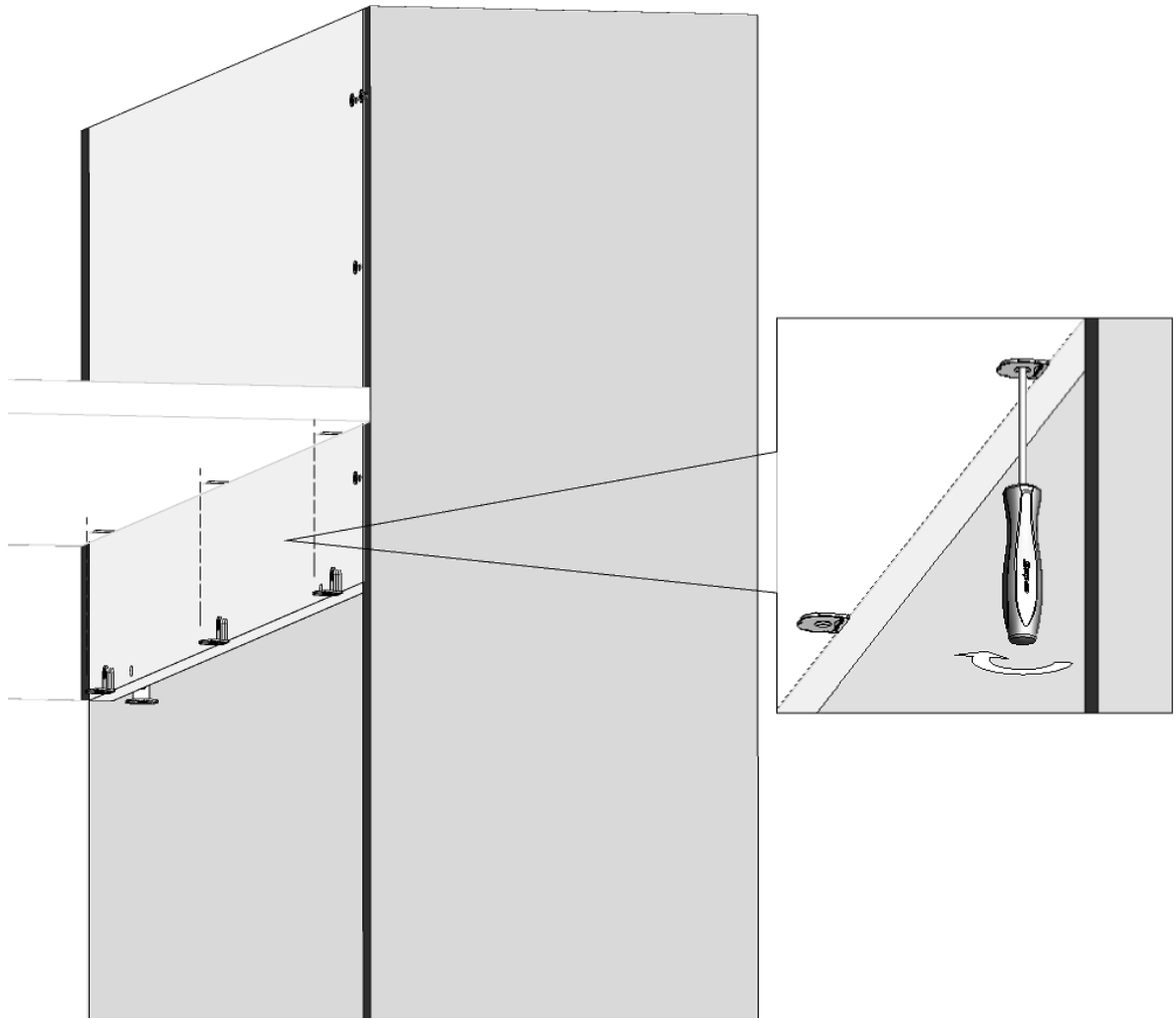



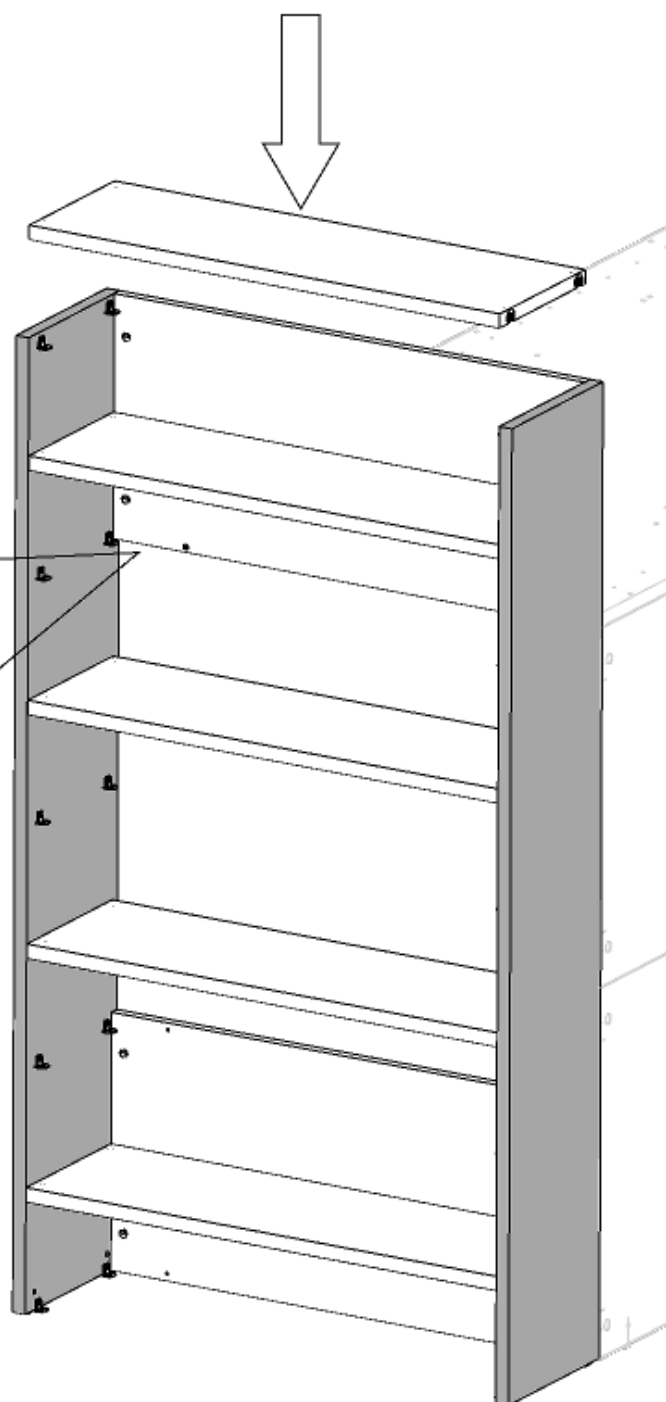
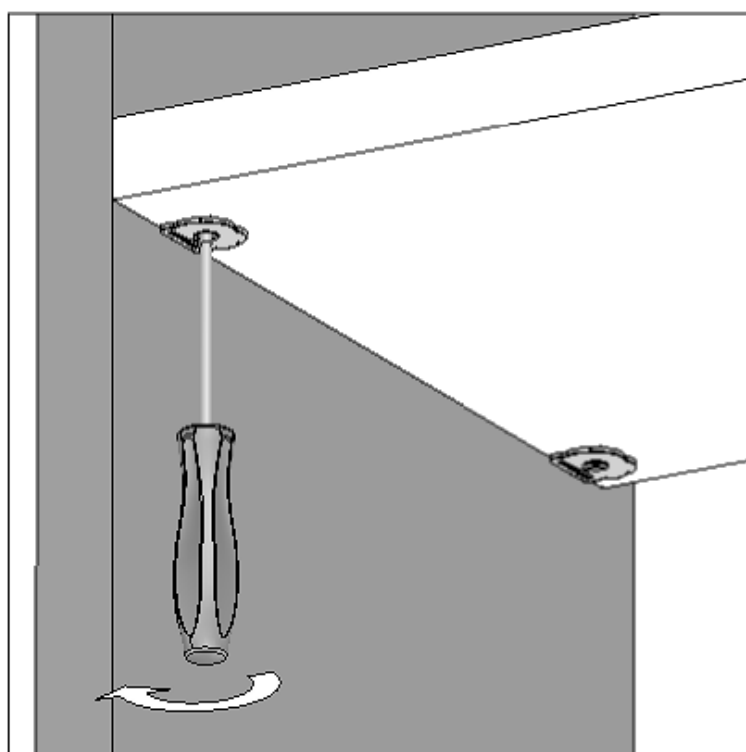

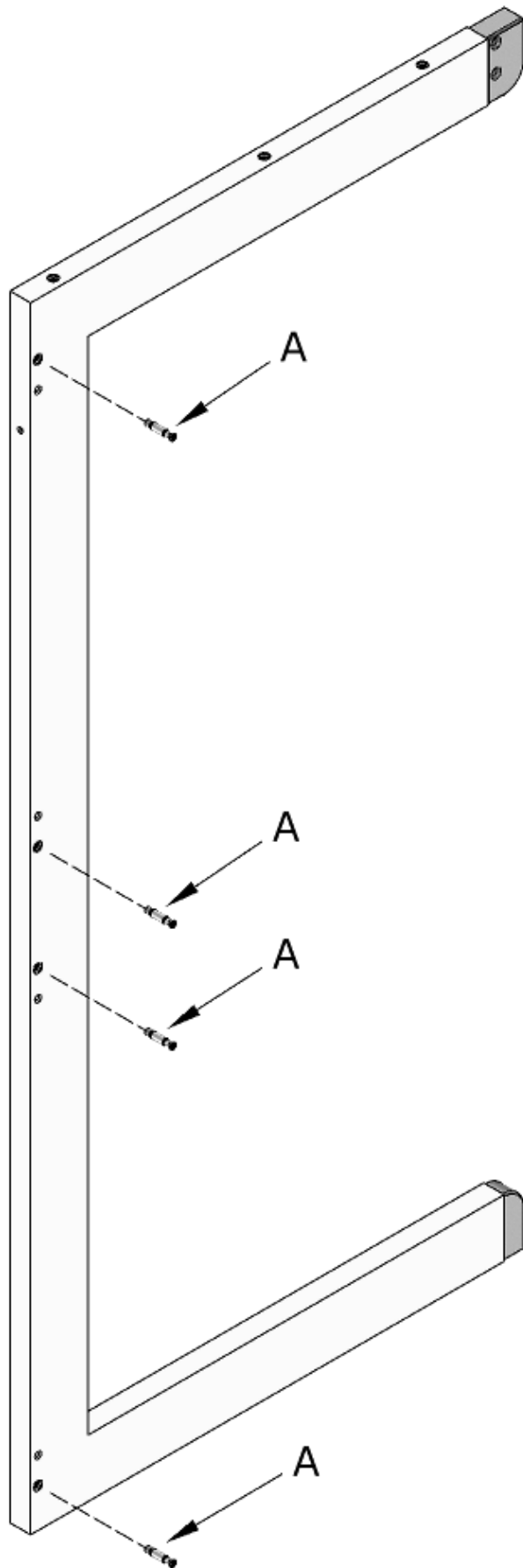



080005081 - SFR\_Sac.Fr.Fianco C Arm-Spp

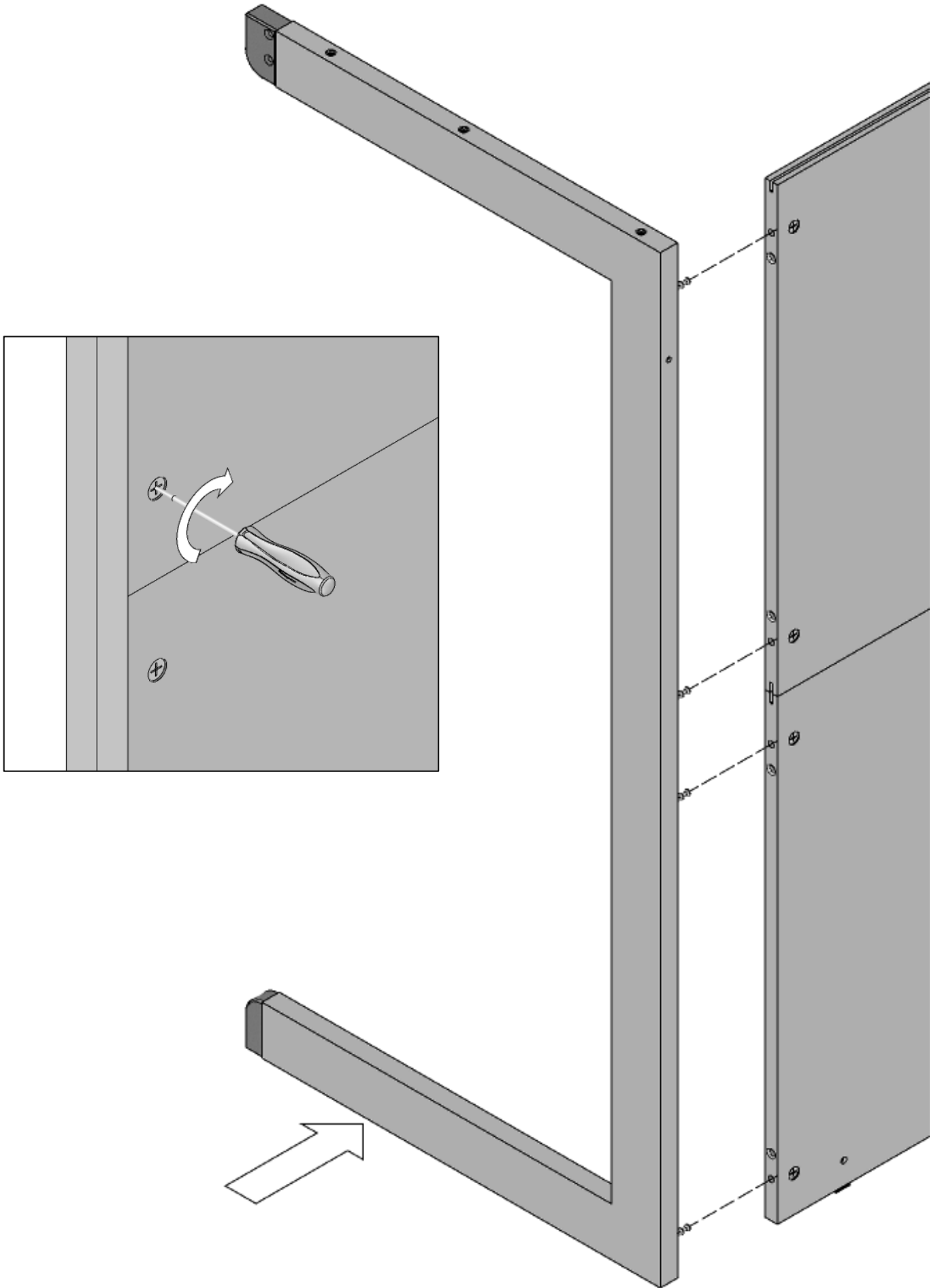

200000668	A		n°7	
-----------	---	---	-----	---

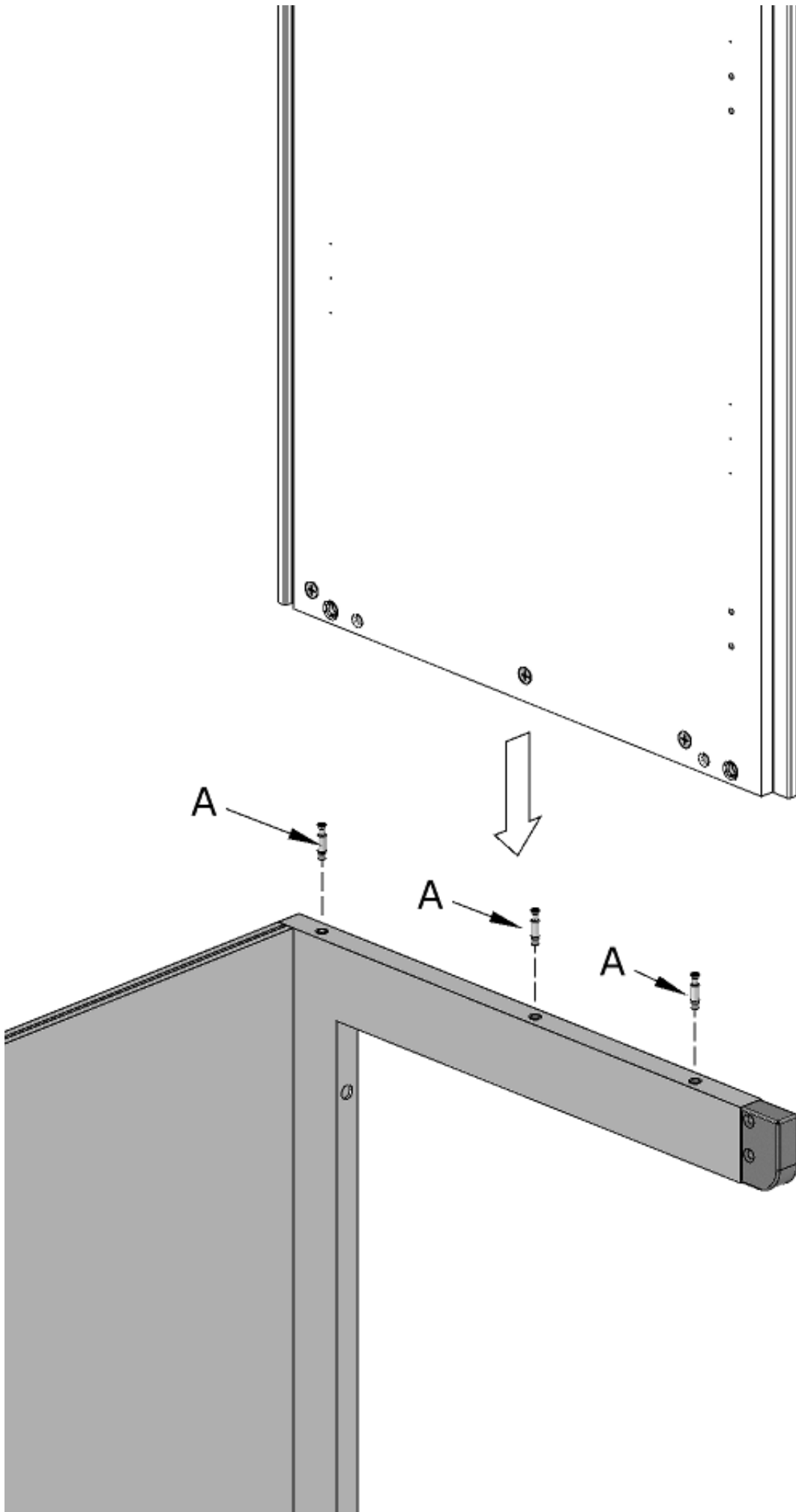

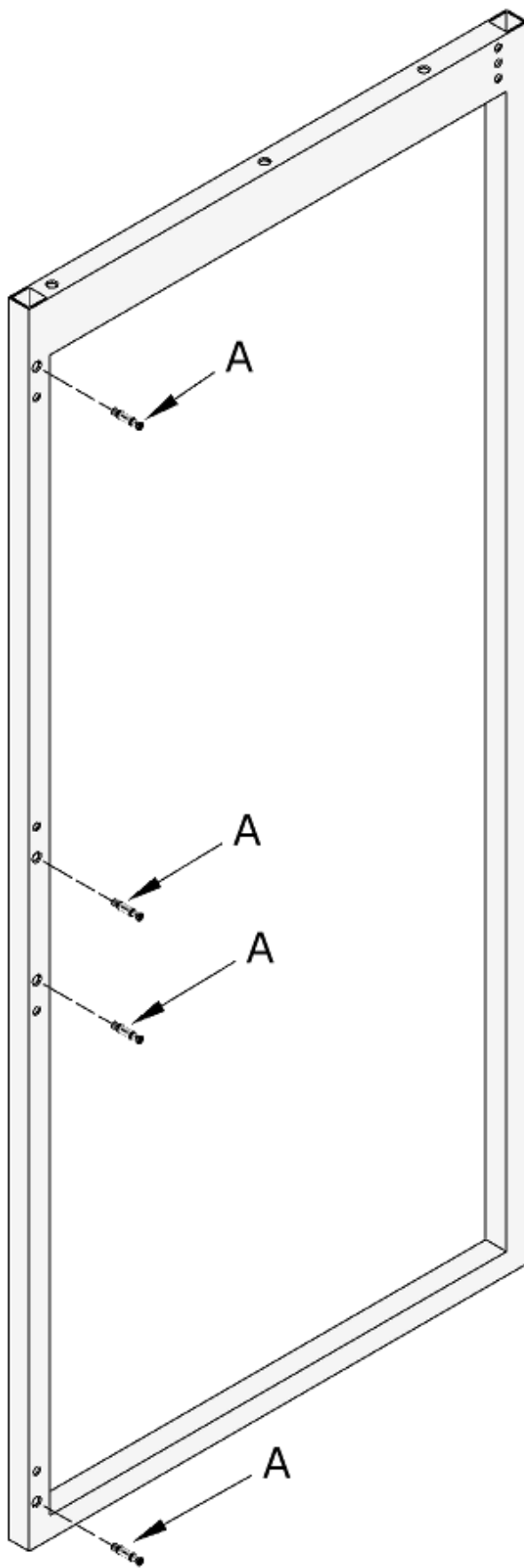





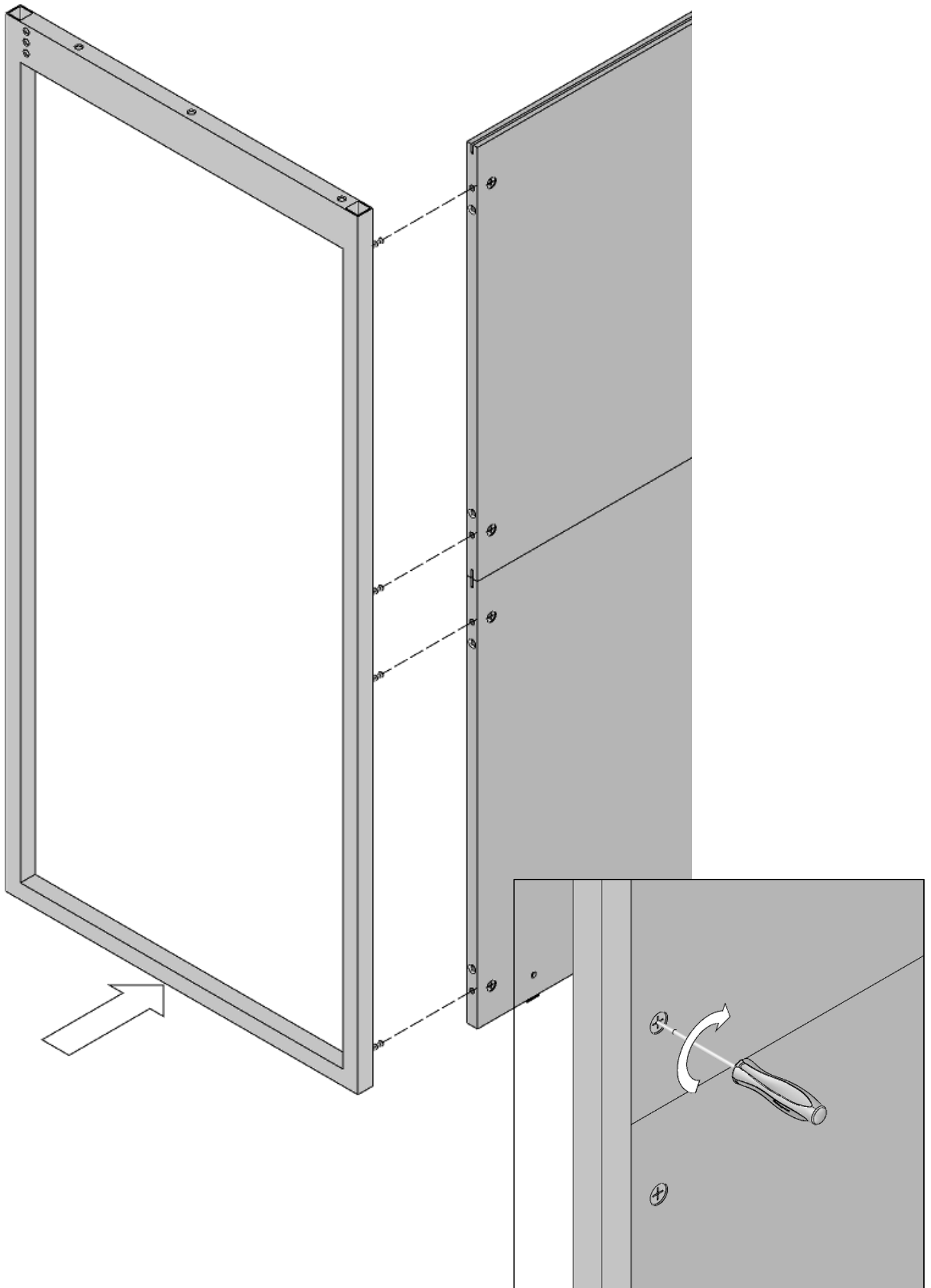

080005081 - SFR\_Sac.Fr.Fianco C Arm-Spp

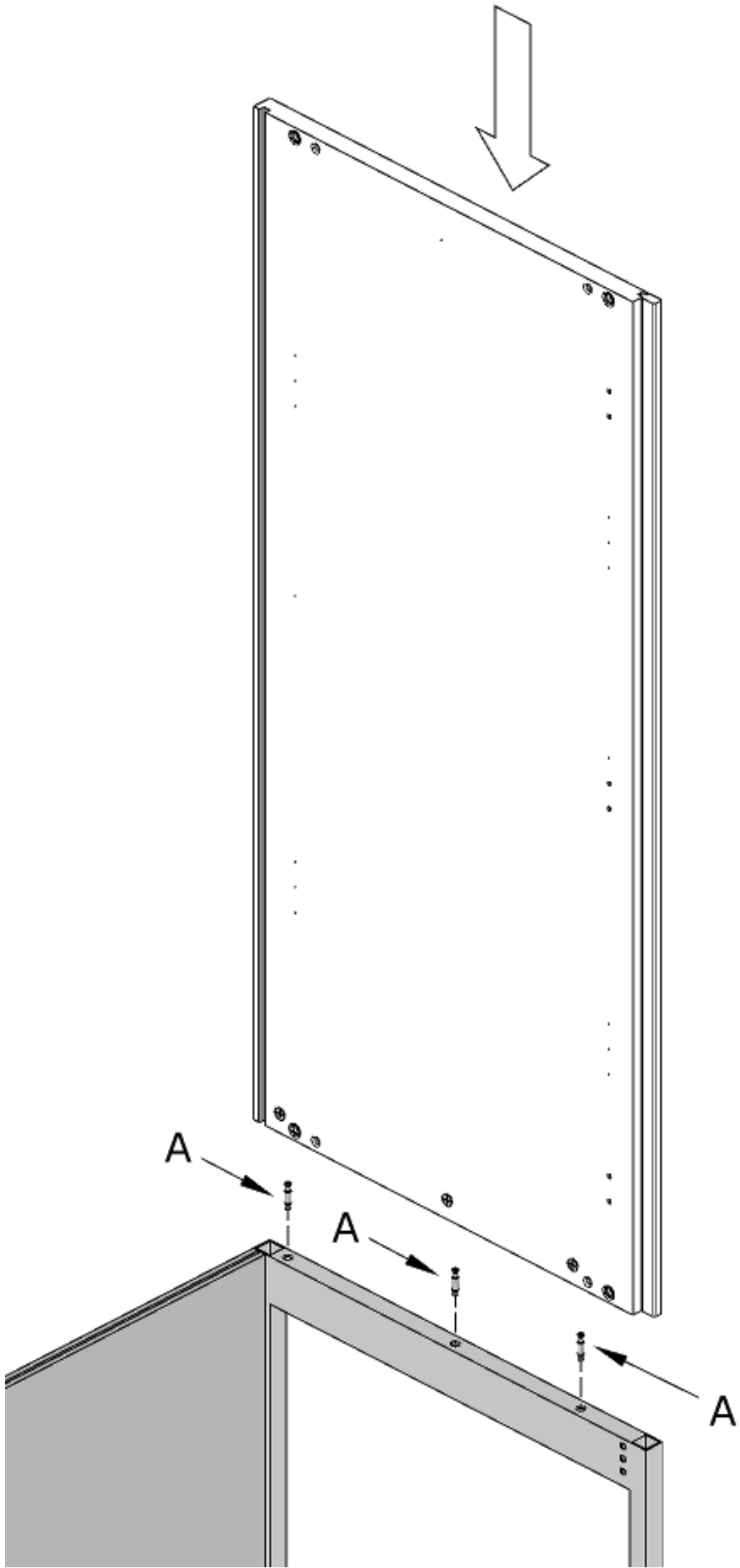
20000668	A		n°7	
----------	---	---	-----	---

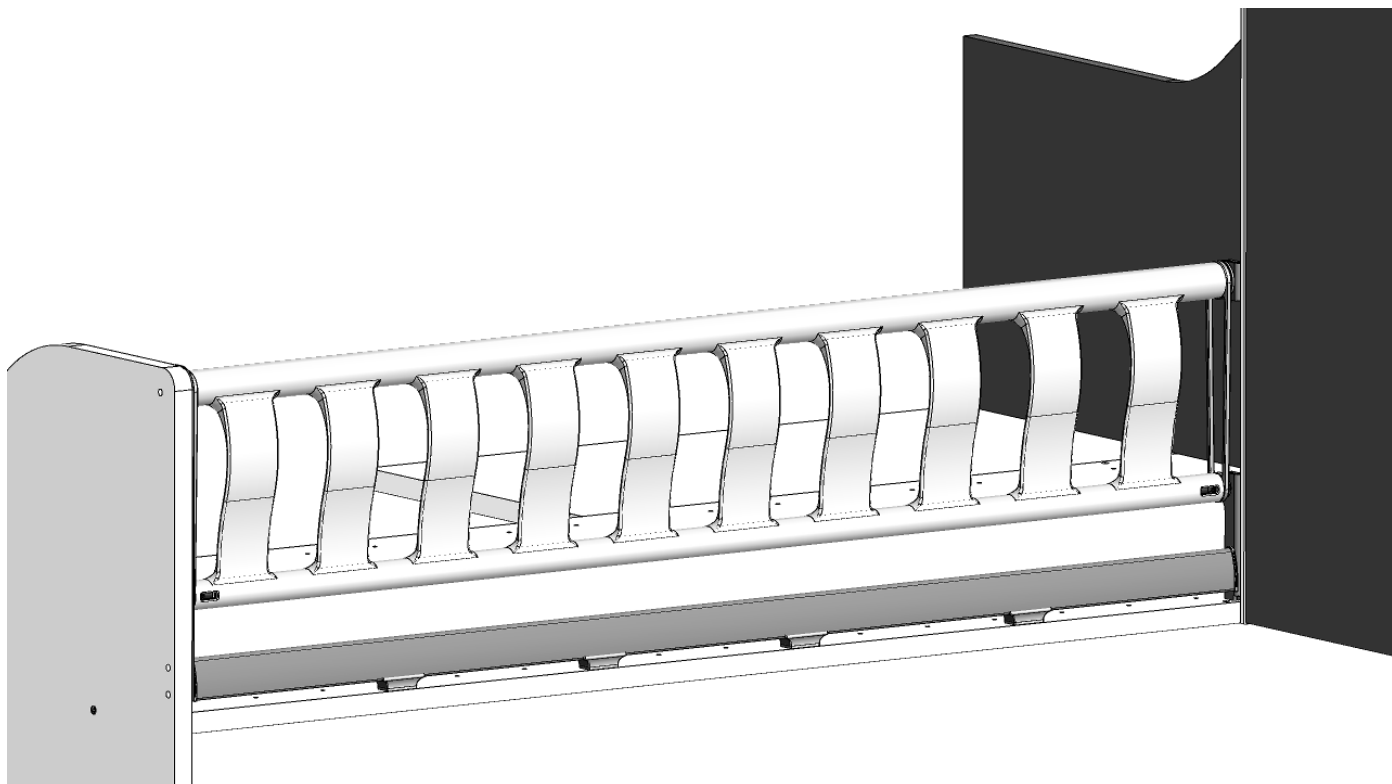



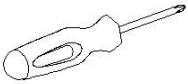
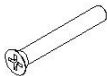

080005827 - SFR_Sac.Fr.Fiss Prot.LongSmall				
200002990	A		<b>n°8</b>	
200000997	B		<b>n°6</b>	
200002160	C		<b>n°1</b>	



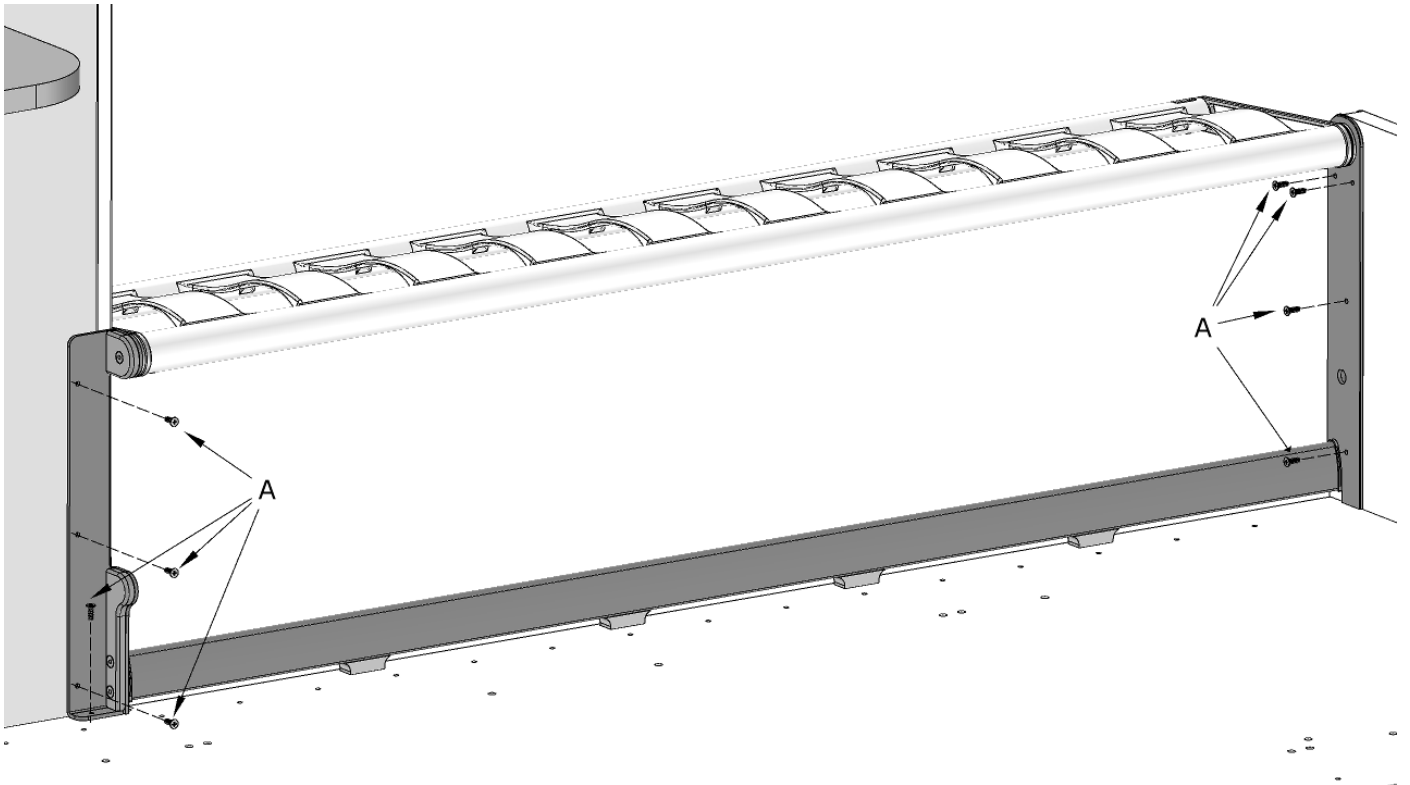
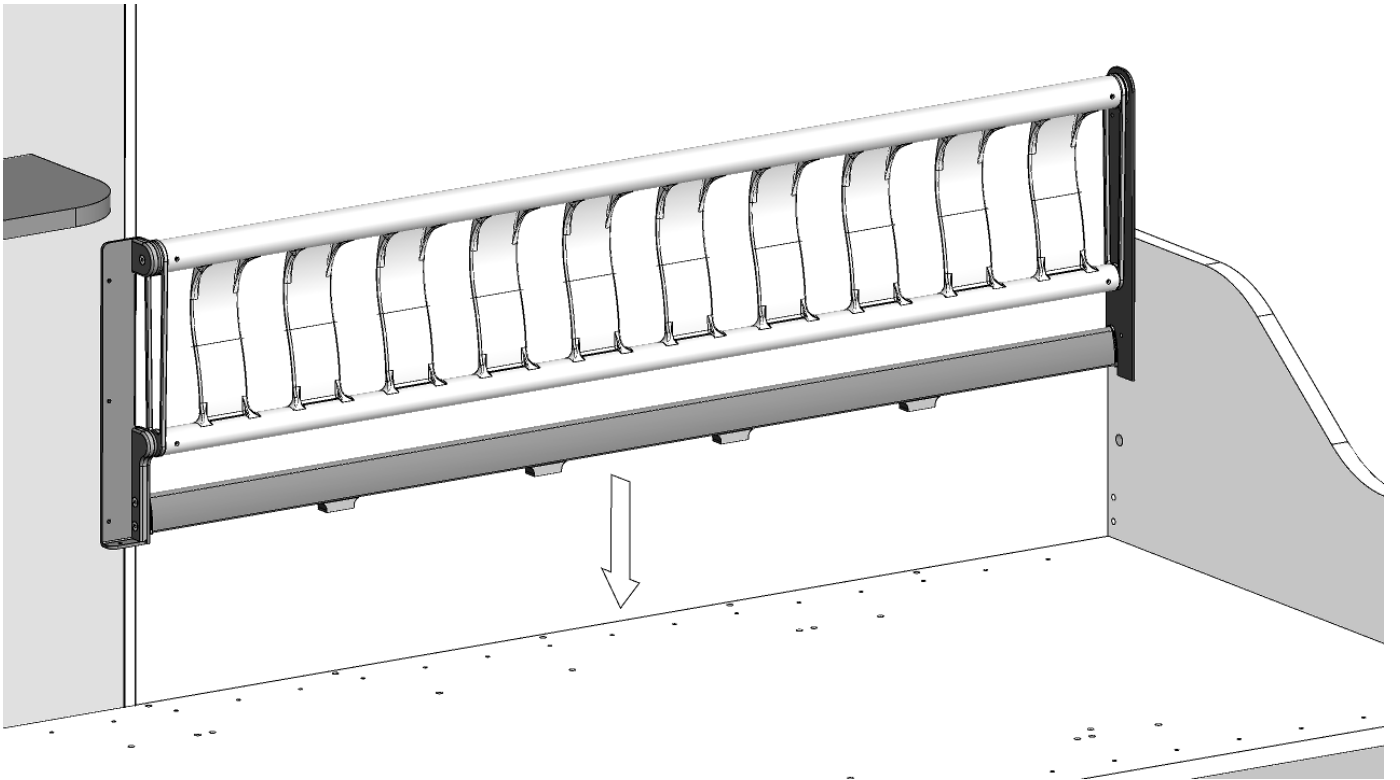

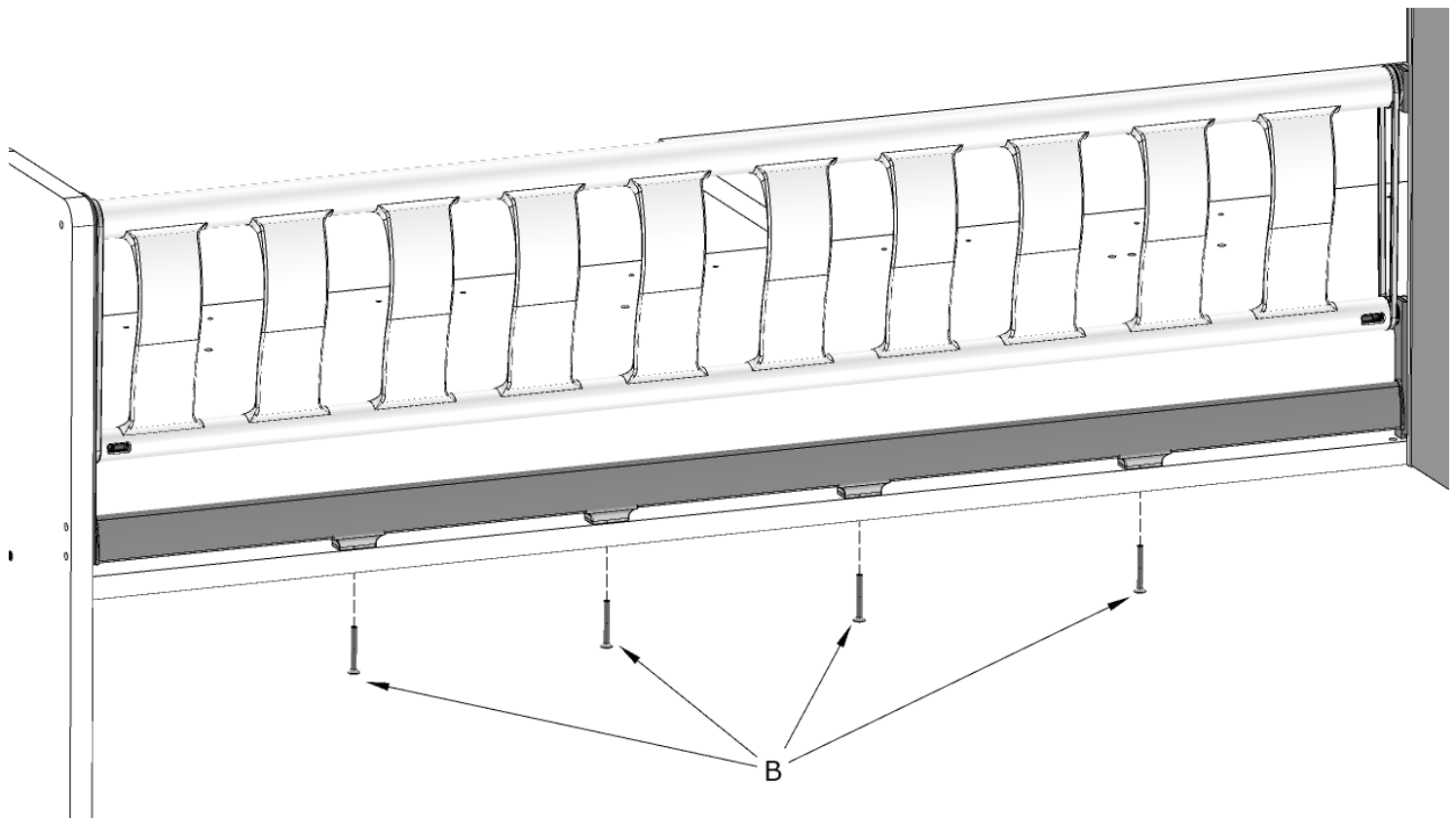

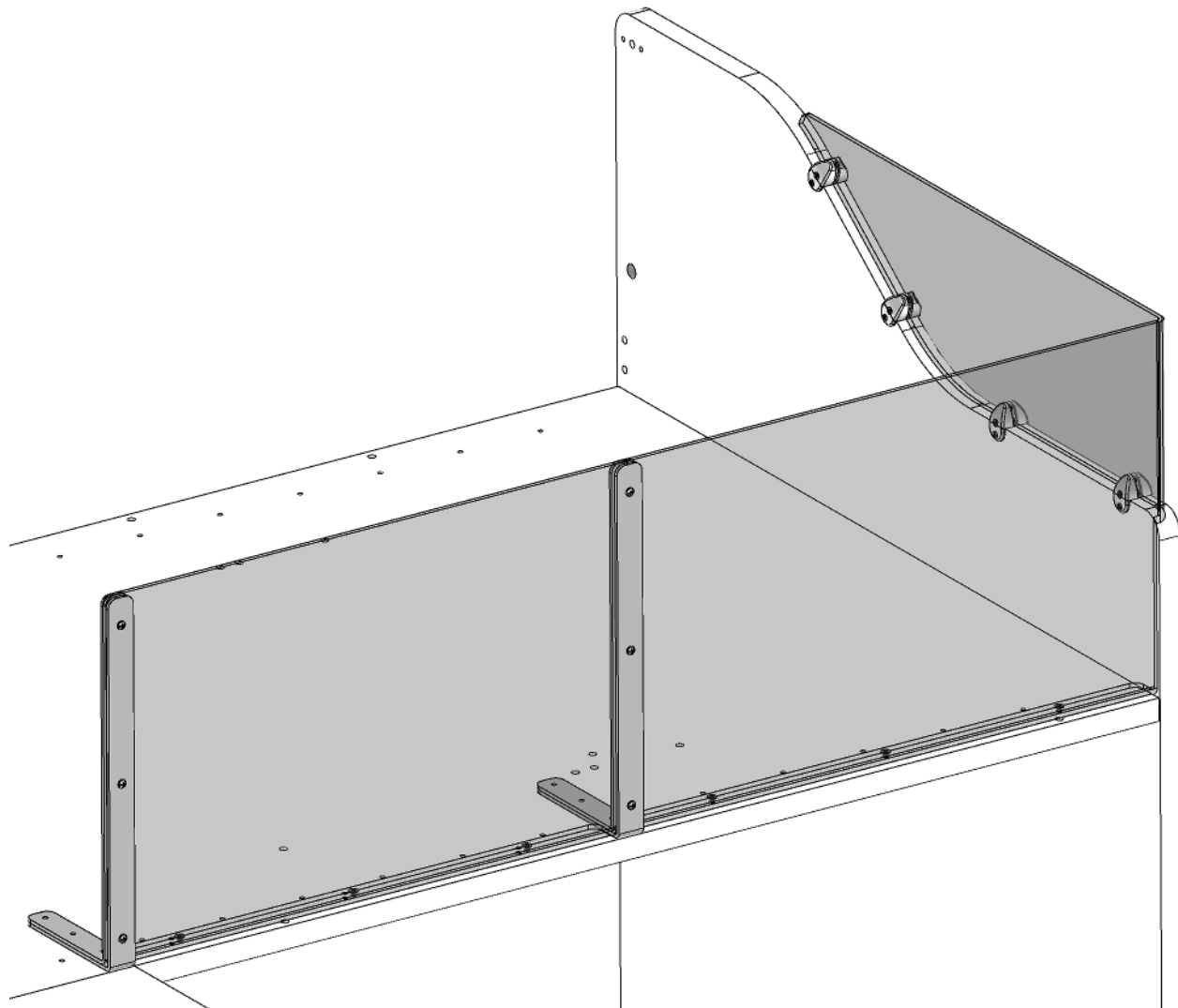



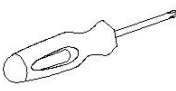
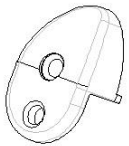

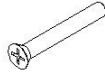



**SFR\_SAC.FR.FISS PROTEZ. SIDE**

	<b>A</b>		<b>n°4</b>	
	<b>B</b>		<b>n°4</b>	
	<b>C</b>		<b>n°4</b>	
	<b>D</b>		<b>n°7</b>	

**080005829 - SFR\_Sac.Fr.Fiss Prt.Posteriore**



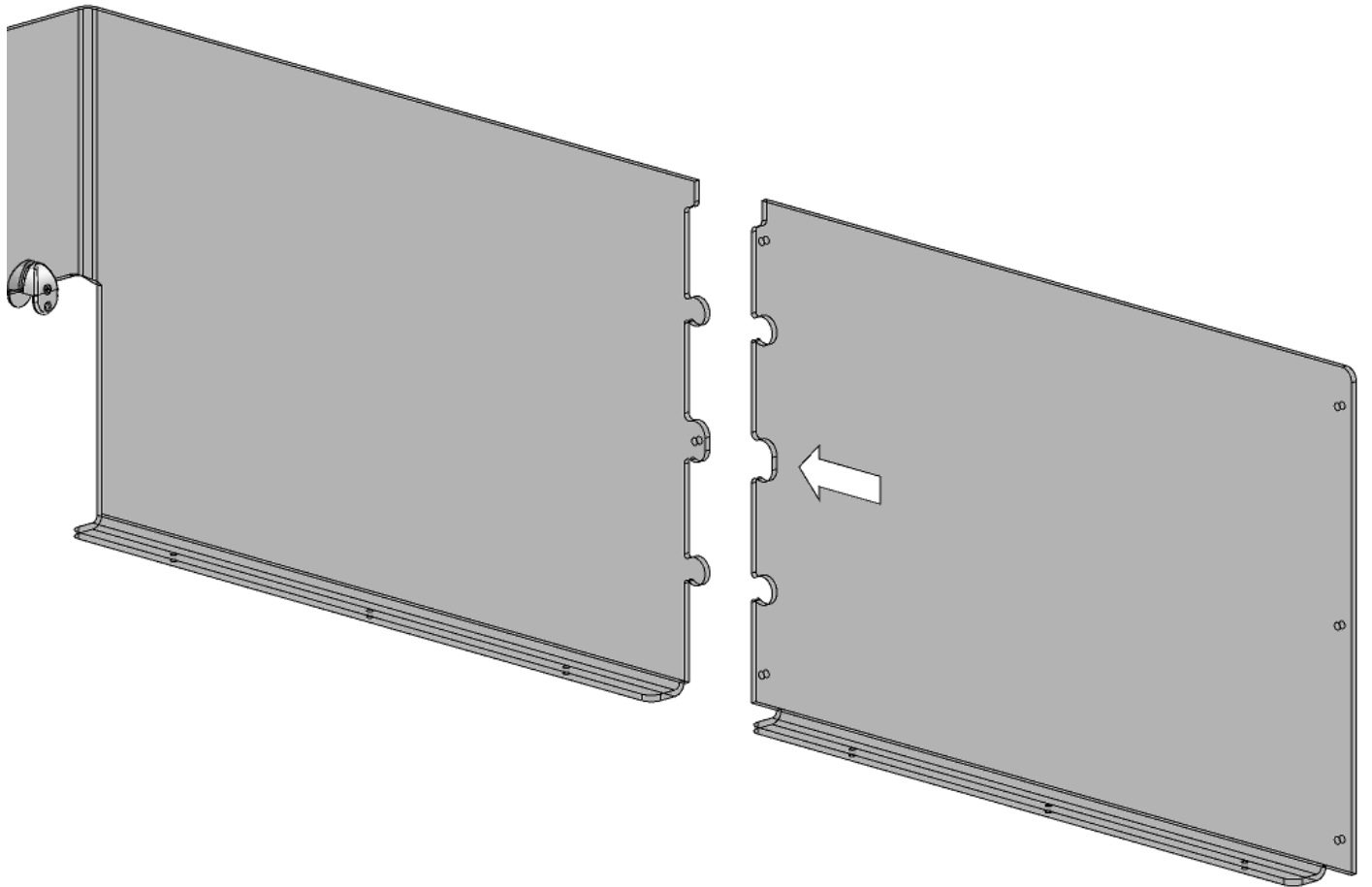
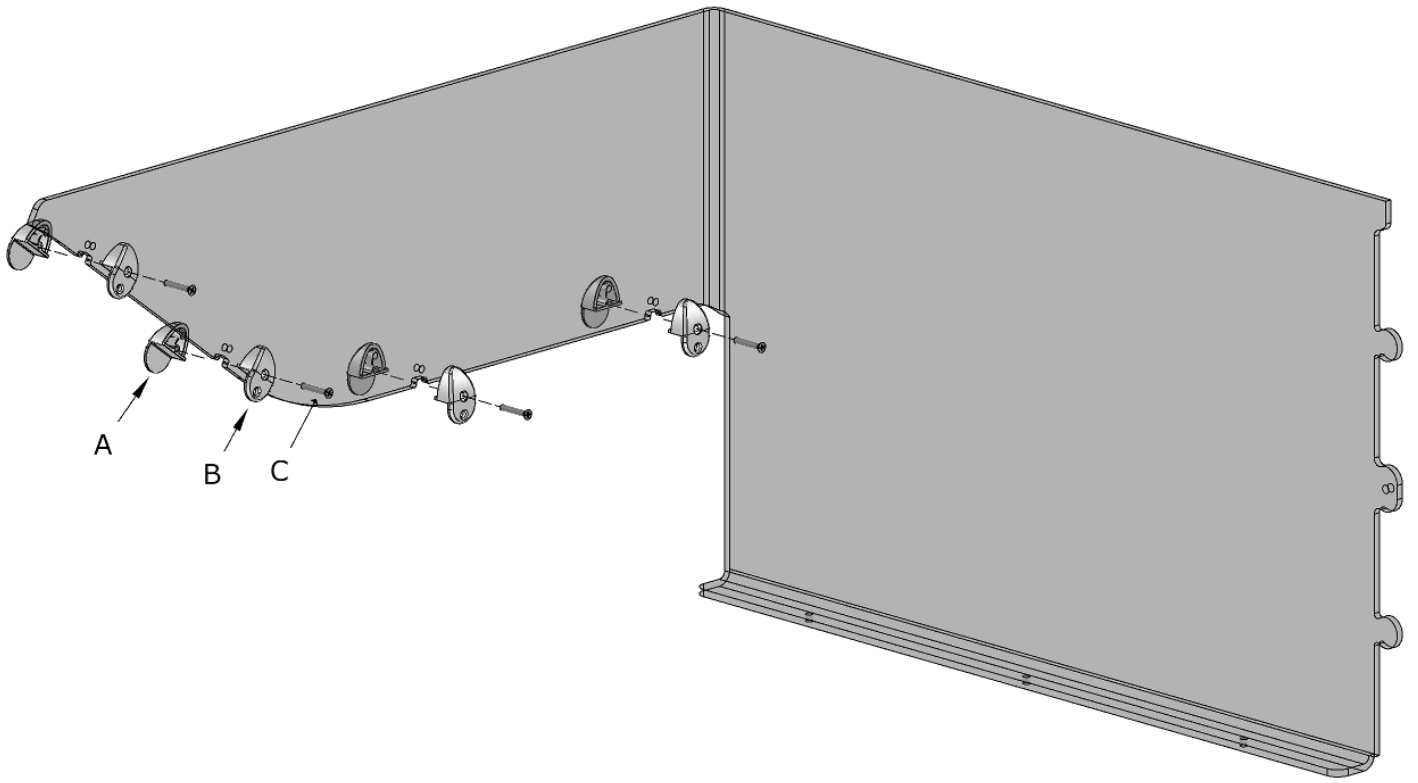

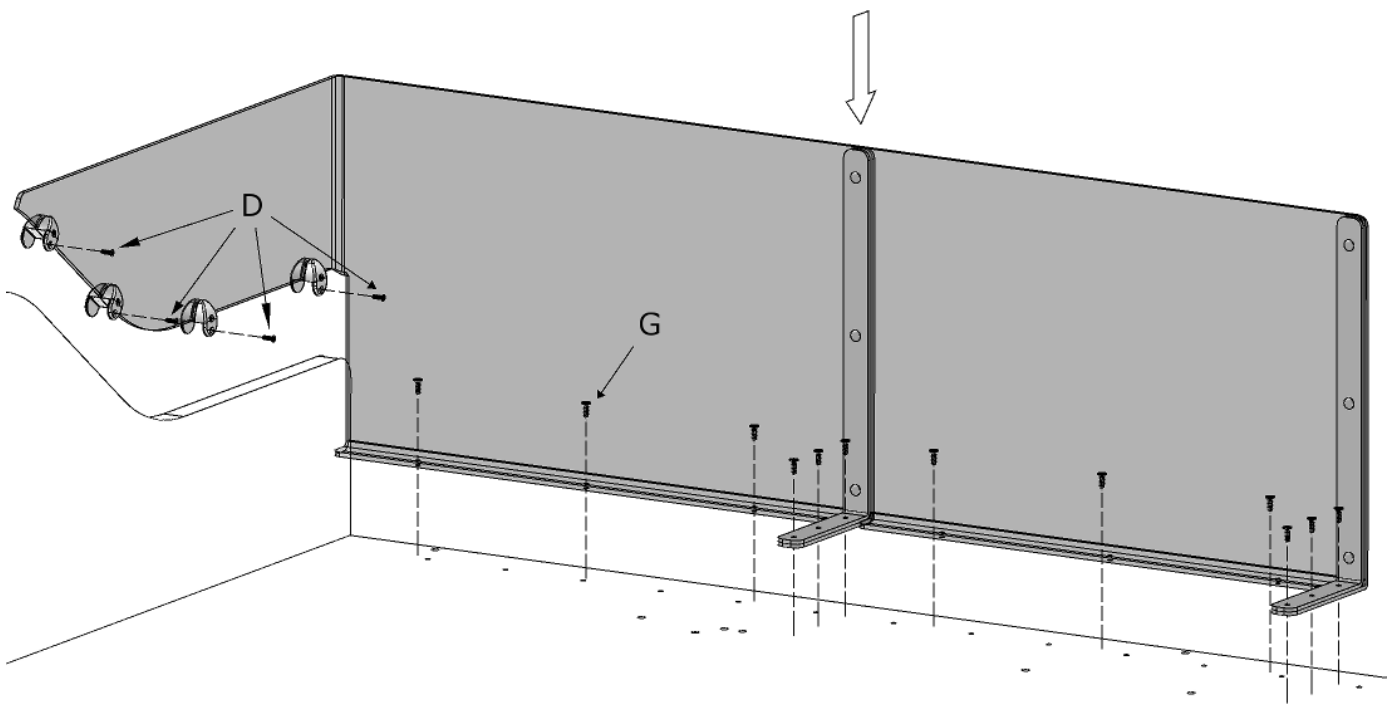
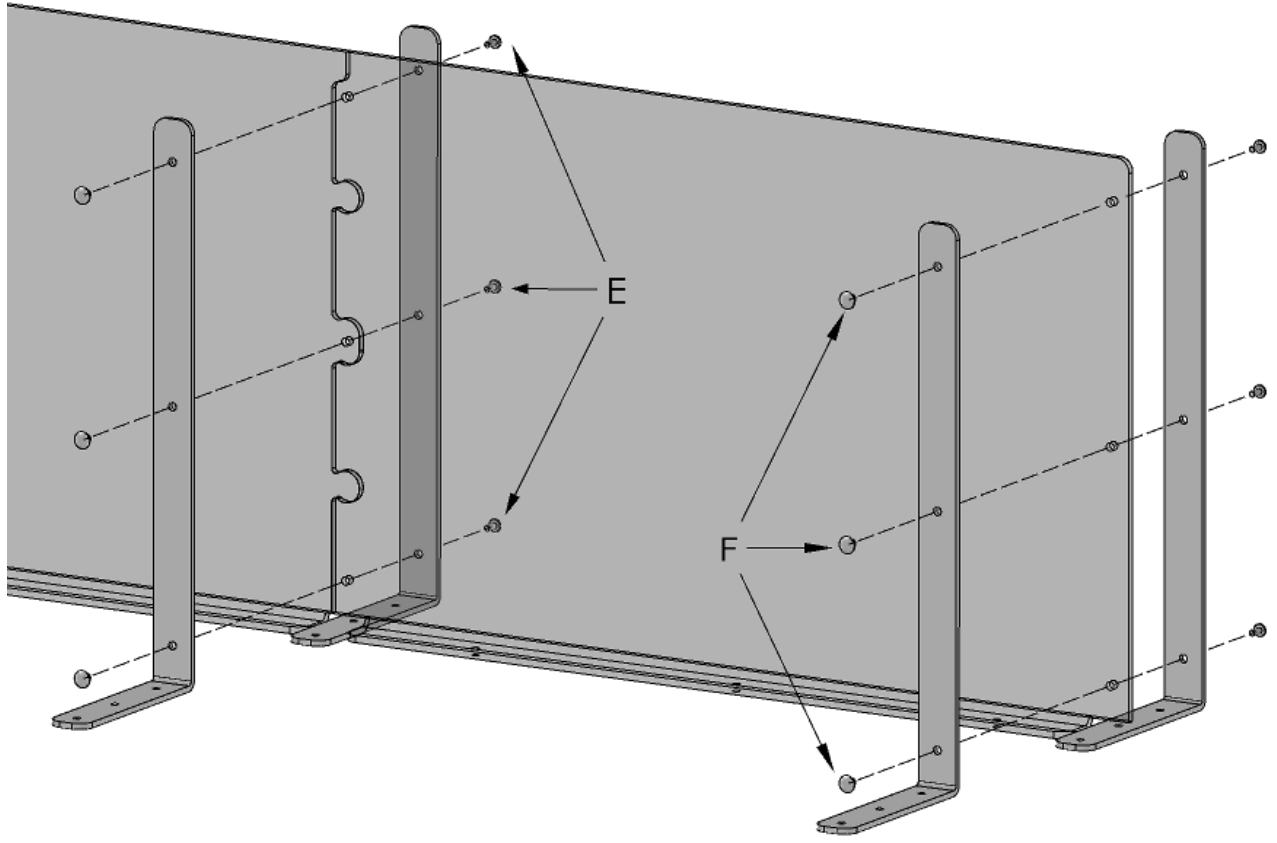

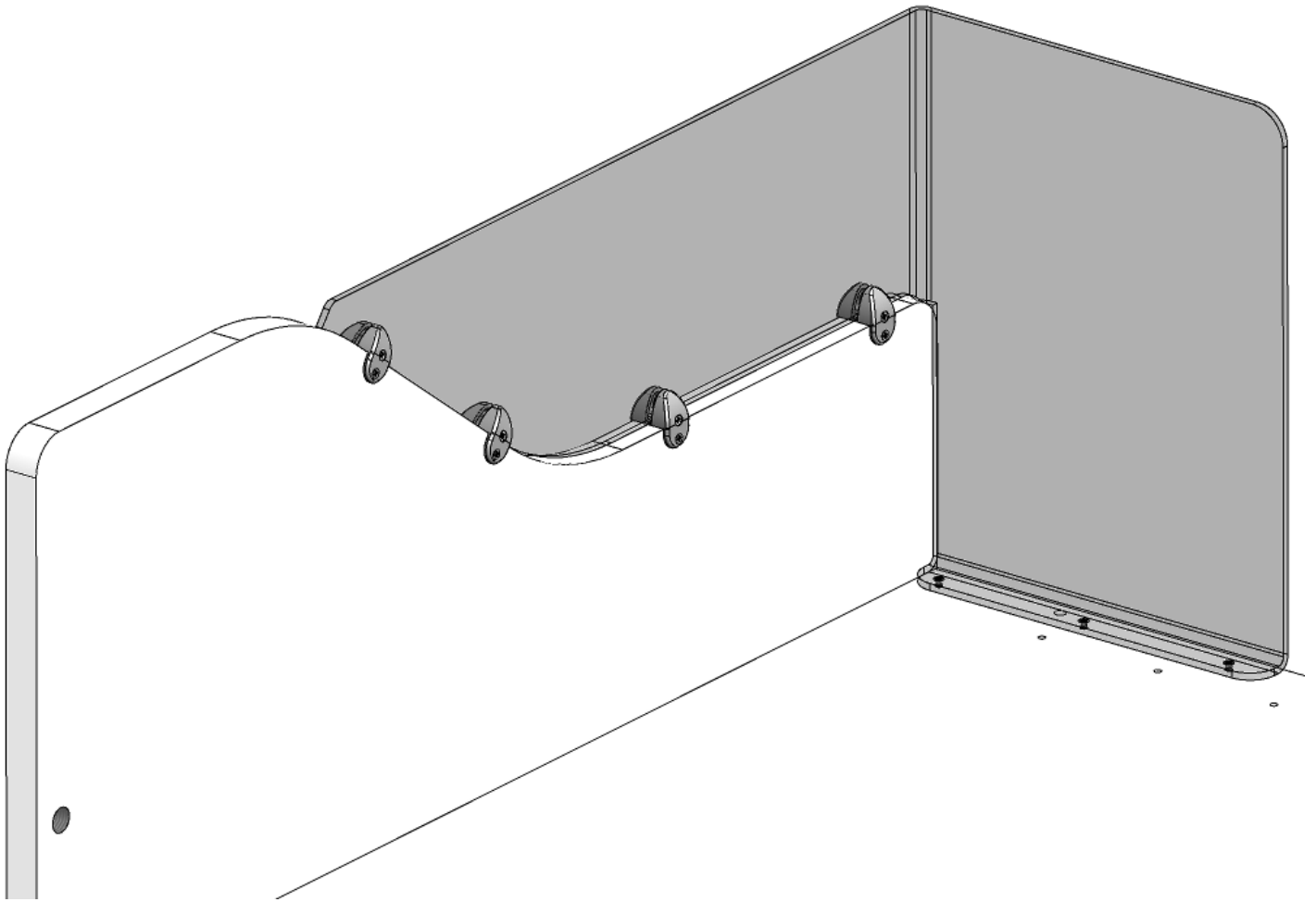
200000920	<b>E</b>		<b>n°6</b>	
200000871	<b>F</b>		<b>n°6</b>	
200002991	<b>G</b>		<b>n°13</b>	







SFR\_SAC.FR.FISS PROTEZ. SIDE

A		n°4	
B		n°4	
C		n°4	
D		n°7	

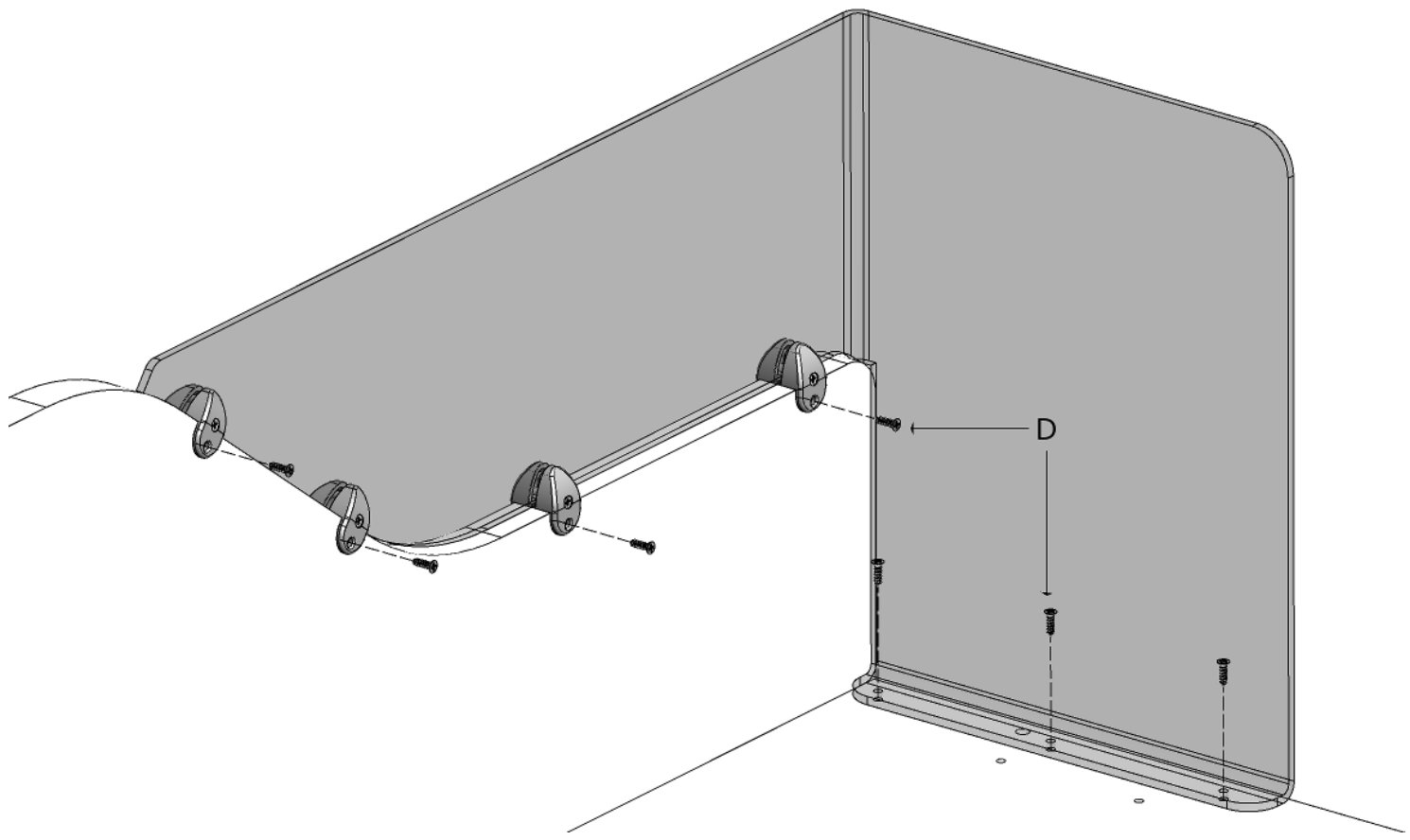
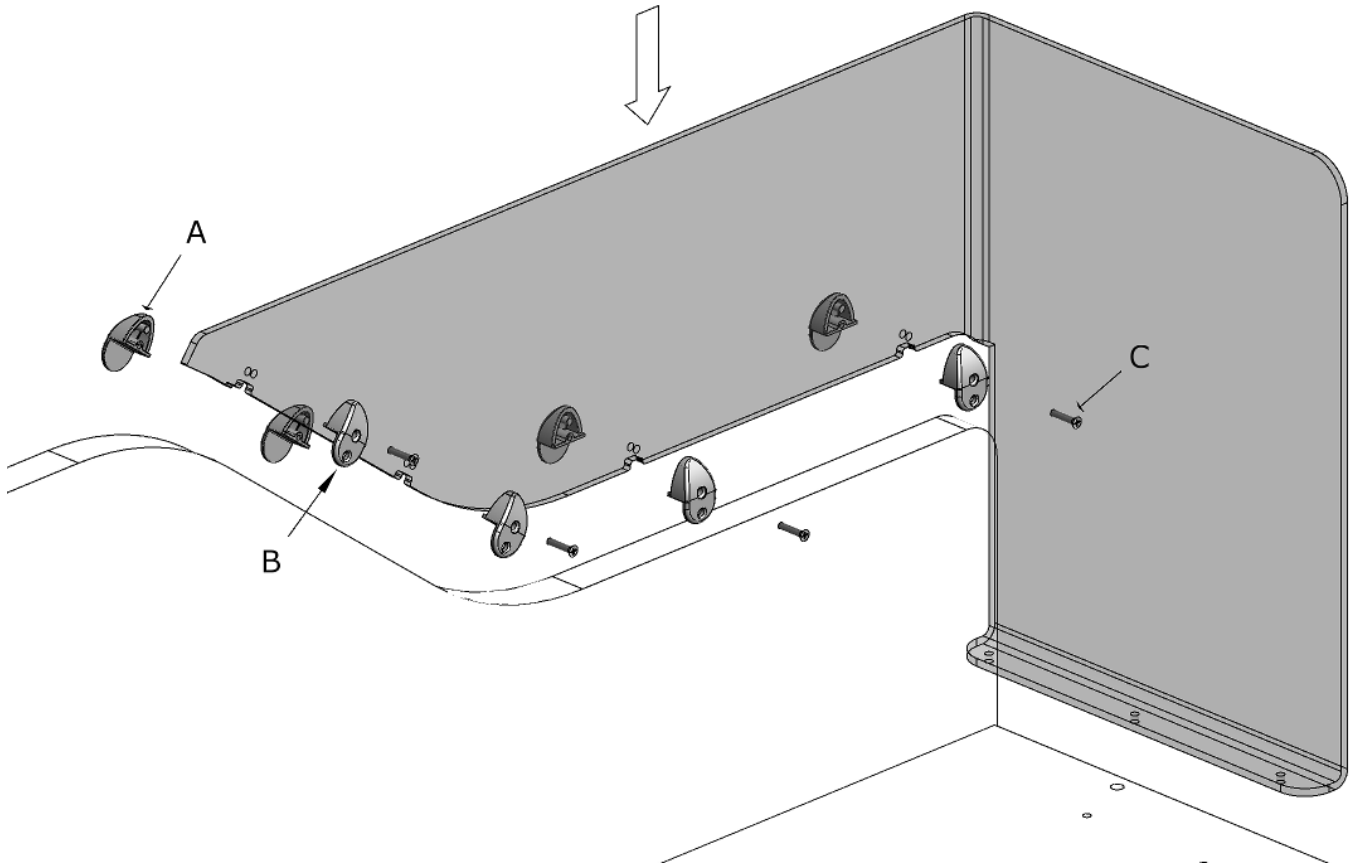





**ATTENZIONE!  
OBBLIGATORIO  
ANCORAGGIO A MURO**

**WARNING!  
WALL ANCHORING  
STRICTLY NEEDED**

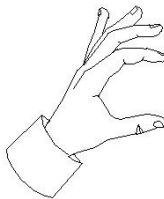
080005831 - SFR\_Sac.Fr.Scl.LatEVO 3Gradini

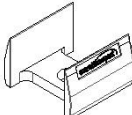
200000666	A		<b>n°10</b>	
200000996	B		<b>n°11</b>	
200002977	C		<b>n°3</b>	



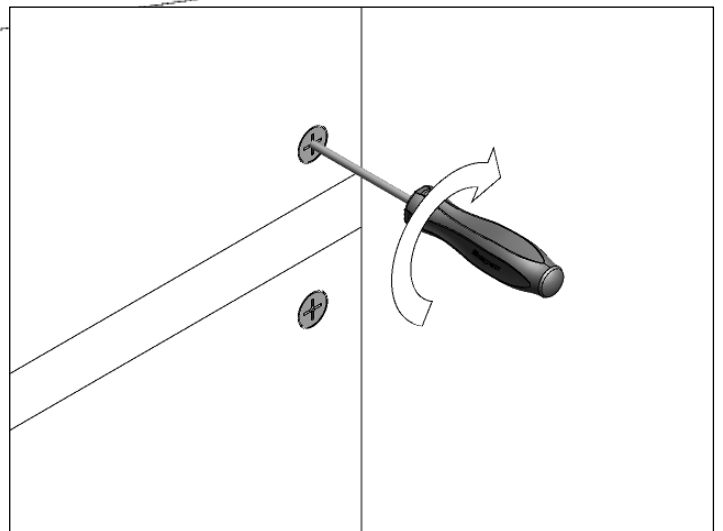
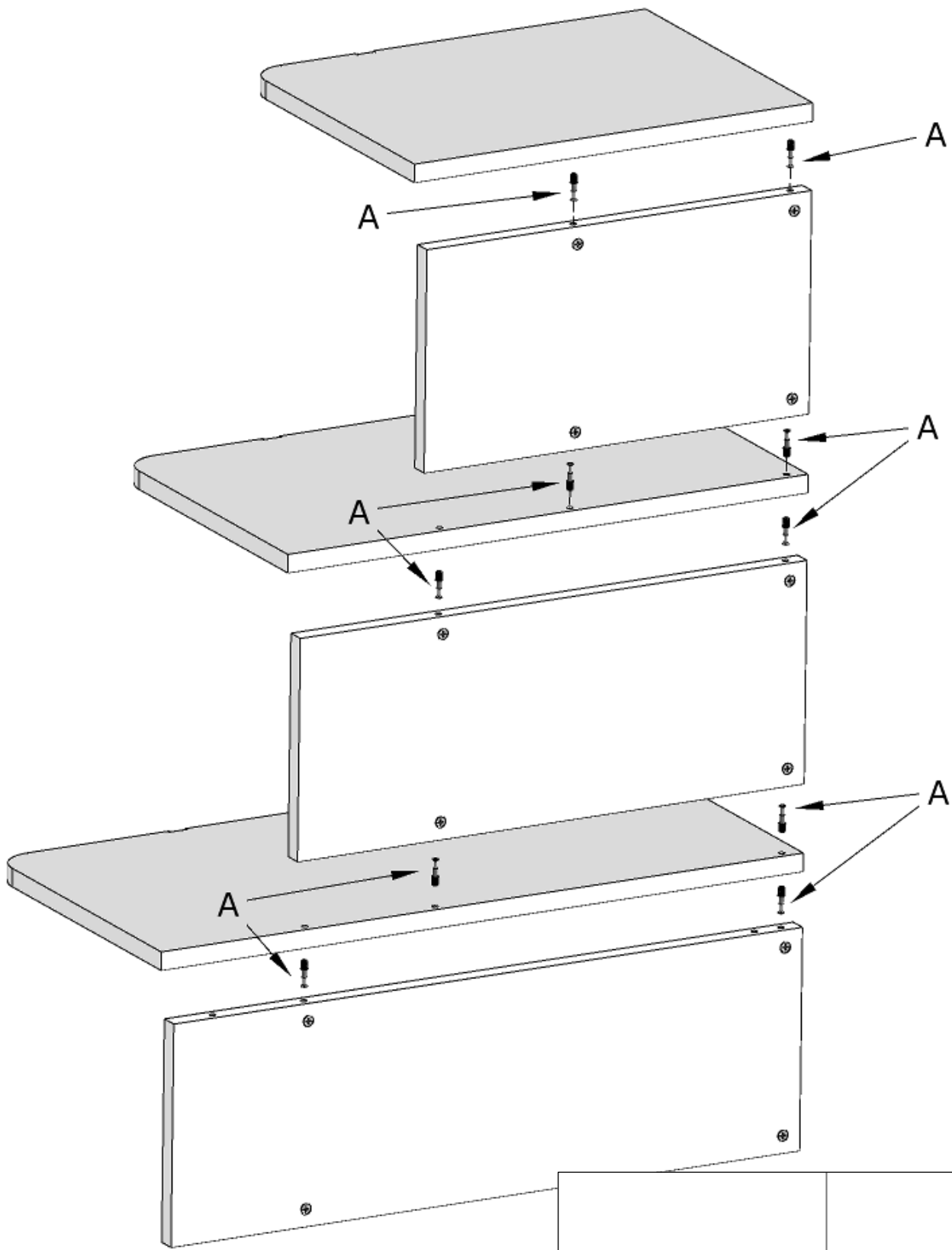

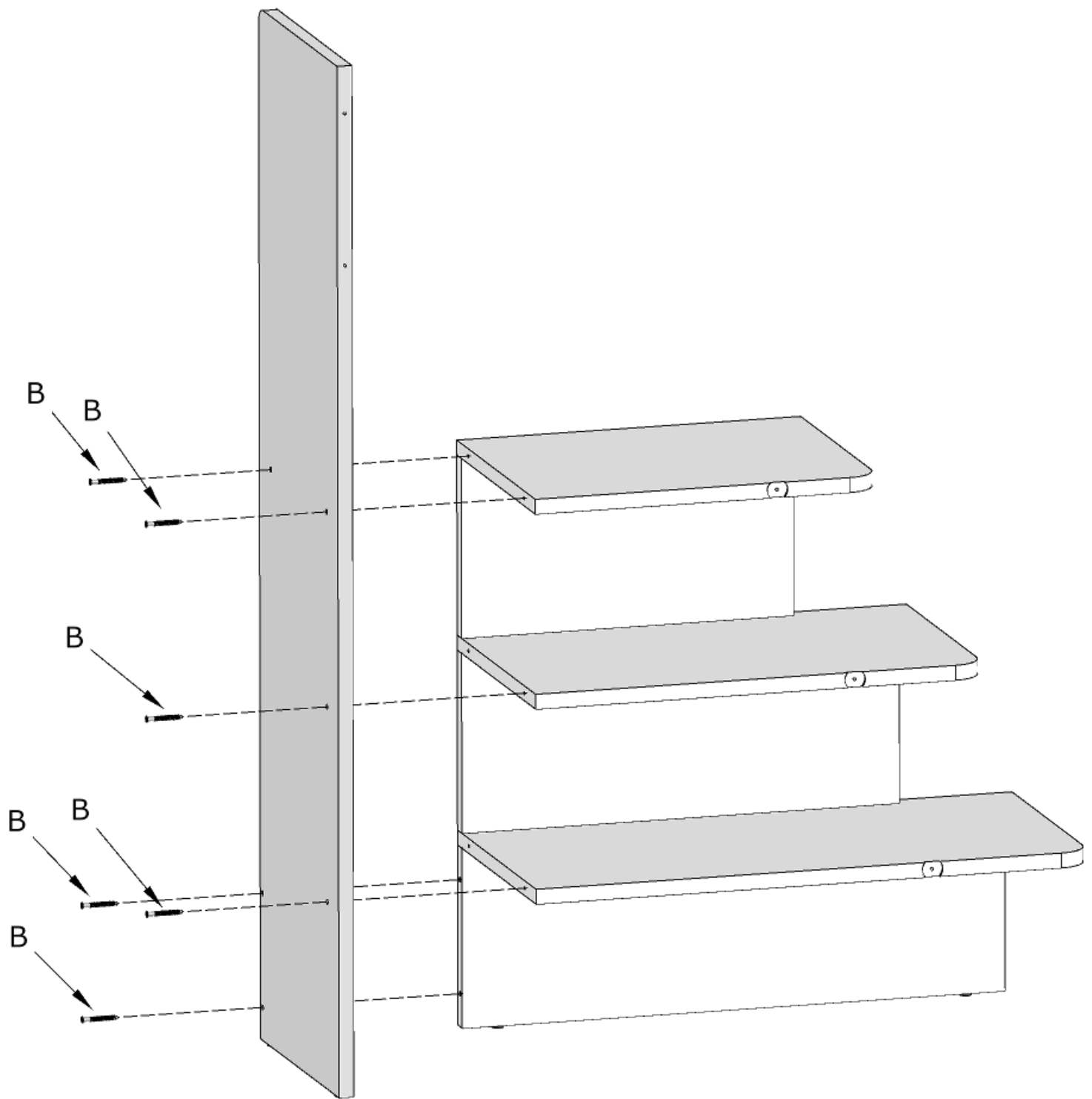

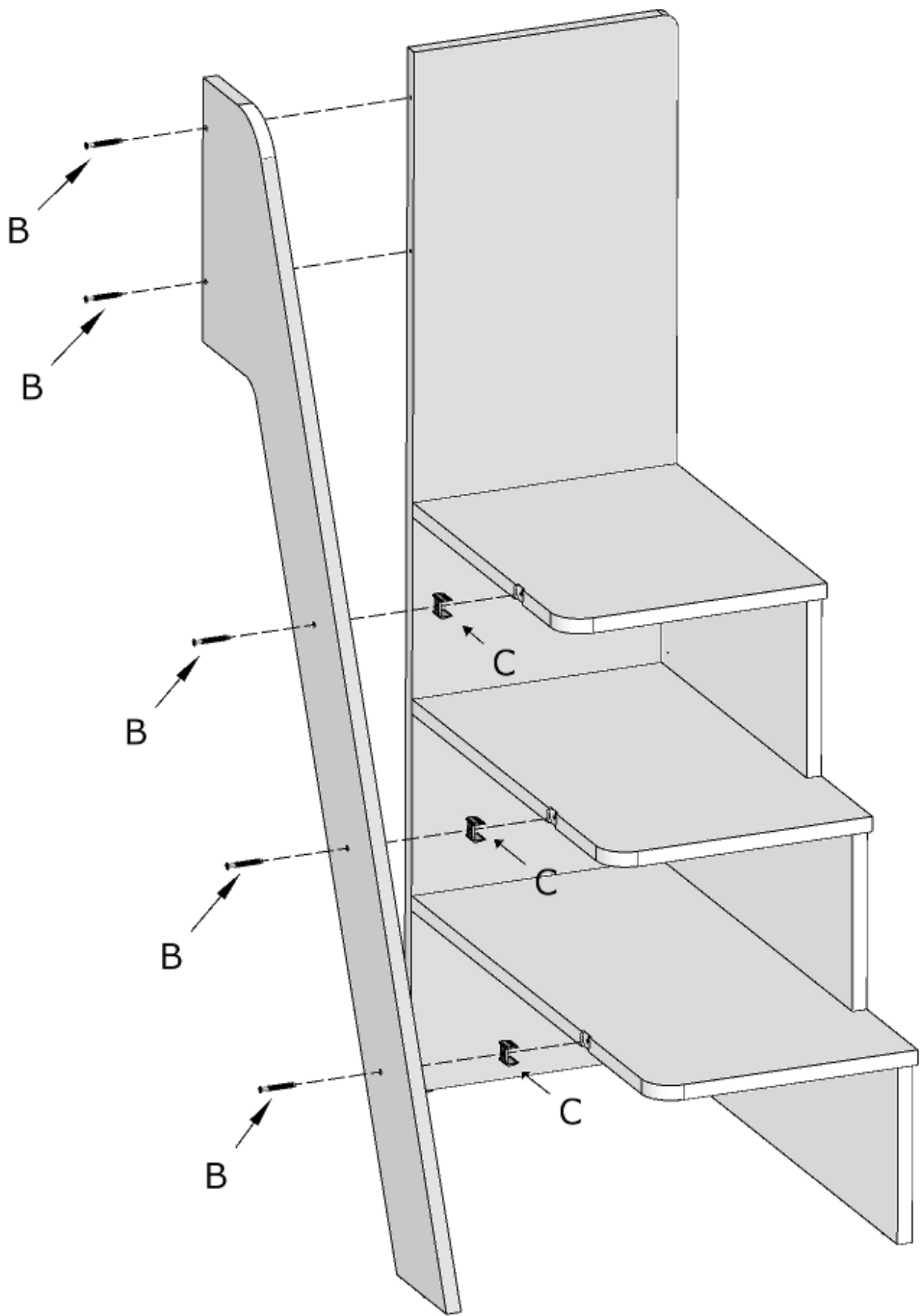

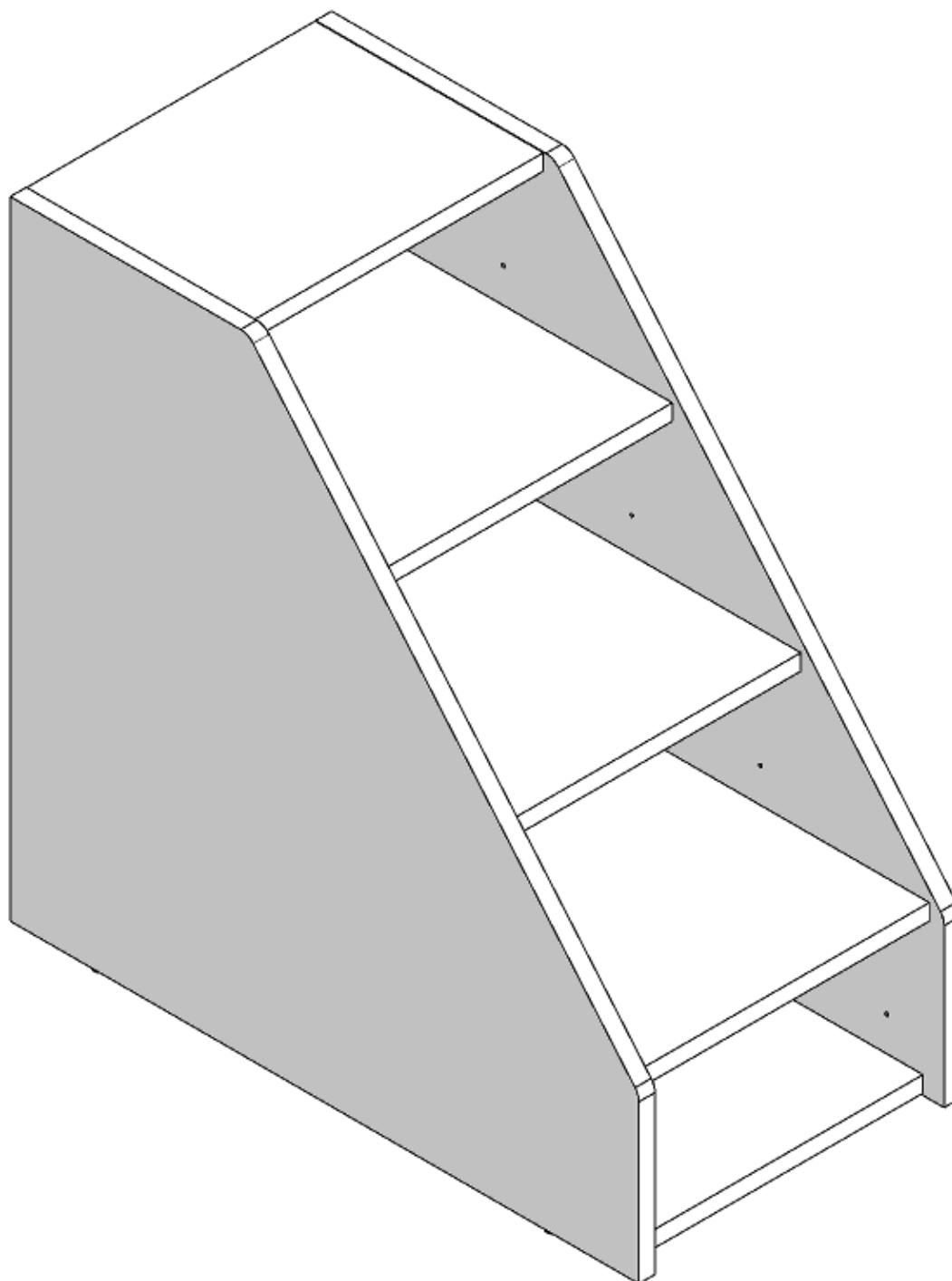

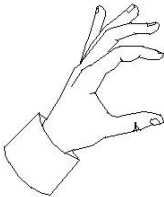

080005111 - SFR_Sac.Fr.Component.1°Scalino				
200000666	A		n°20	
200000653	B		n°36	
200000942	C		n°10	

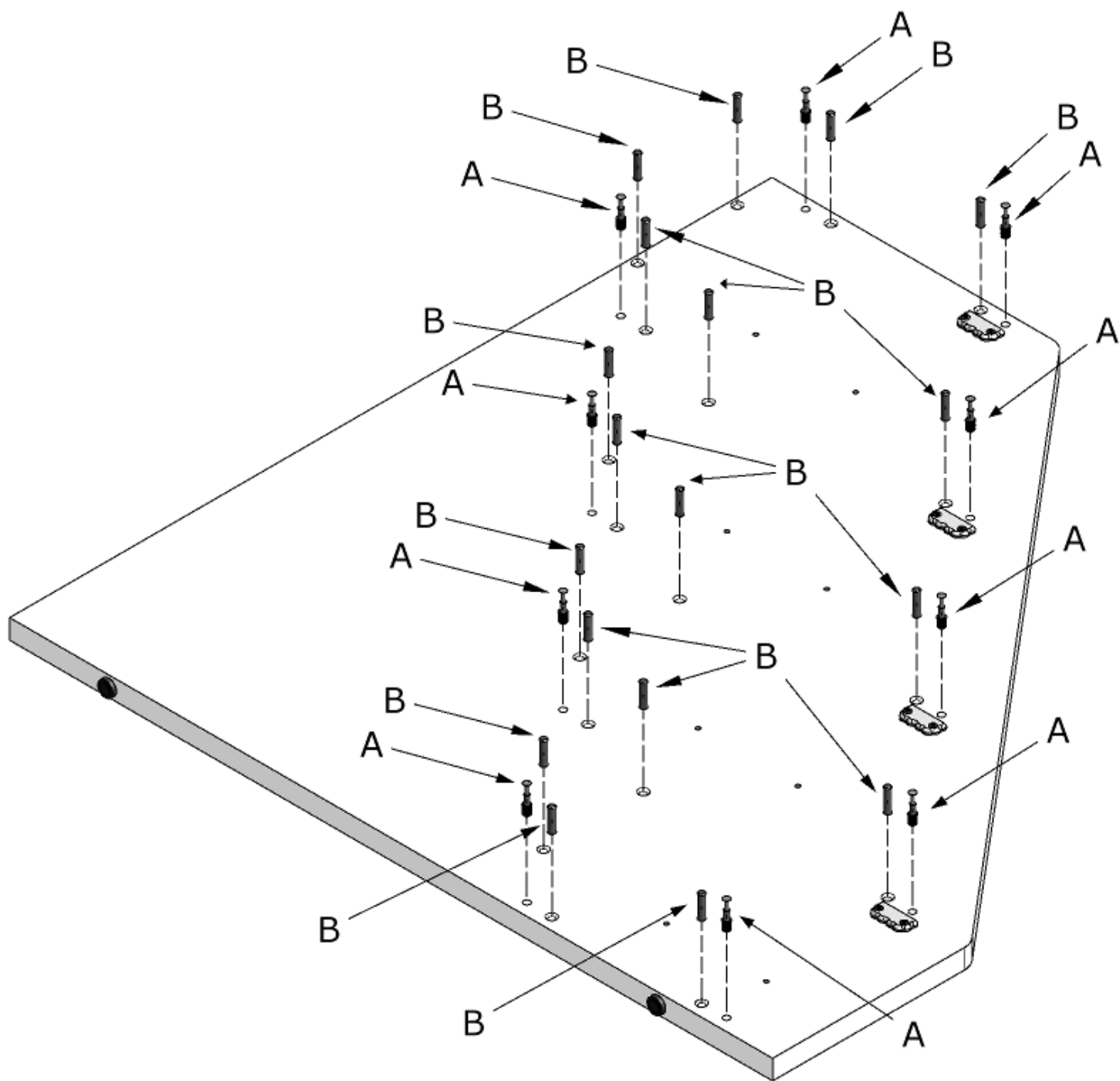

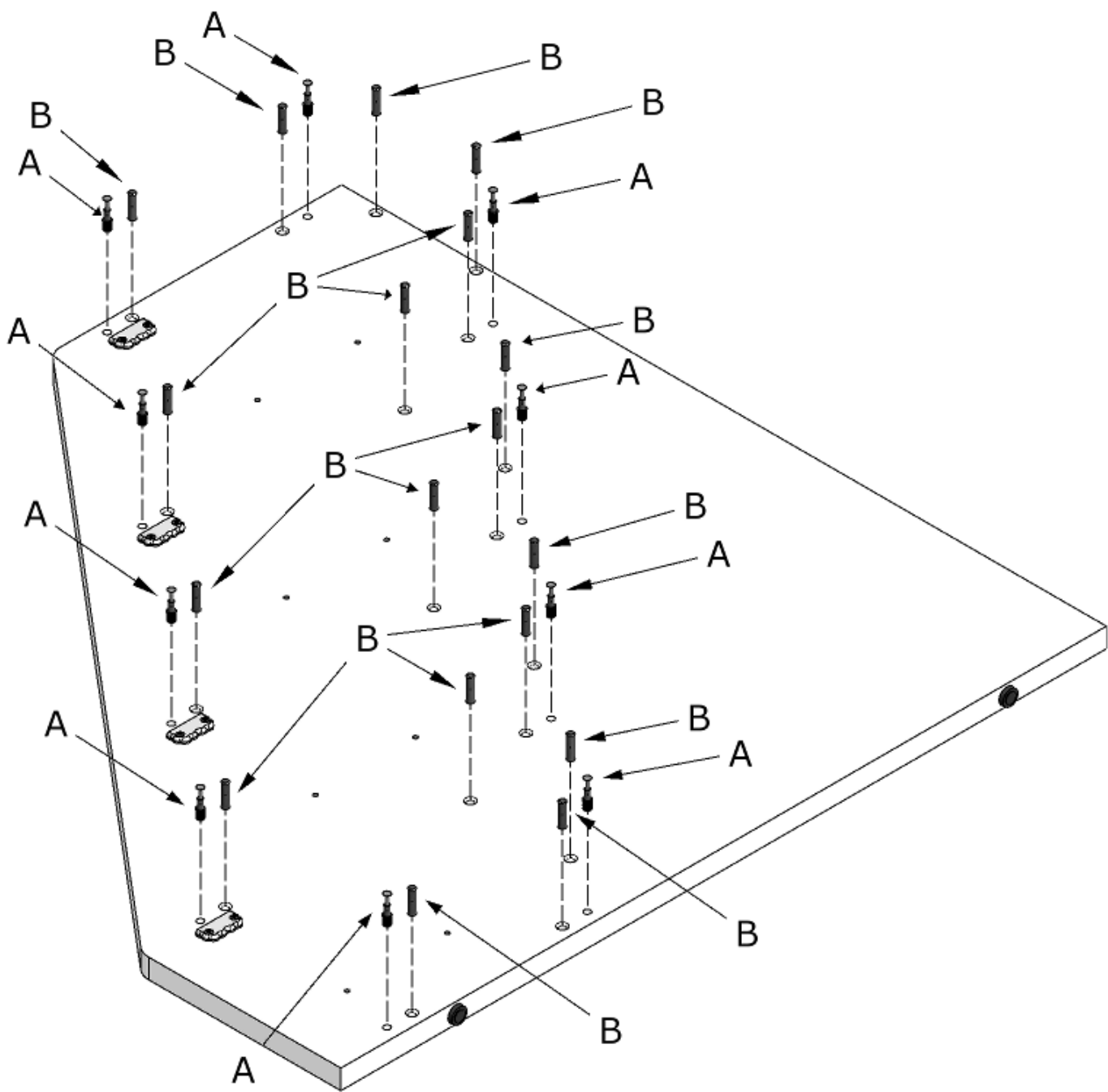

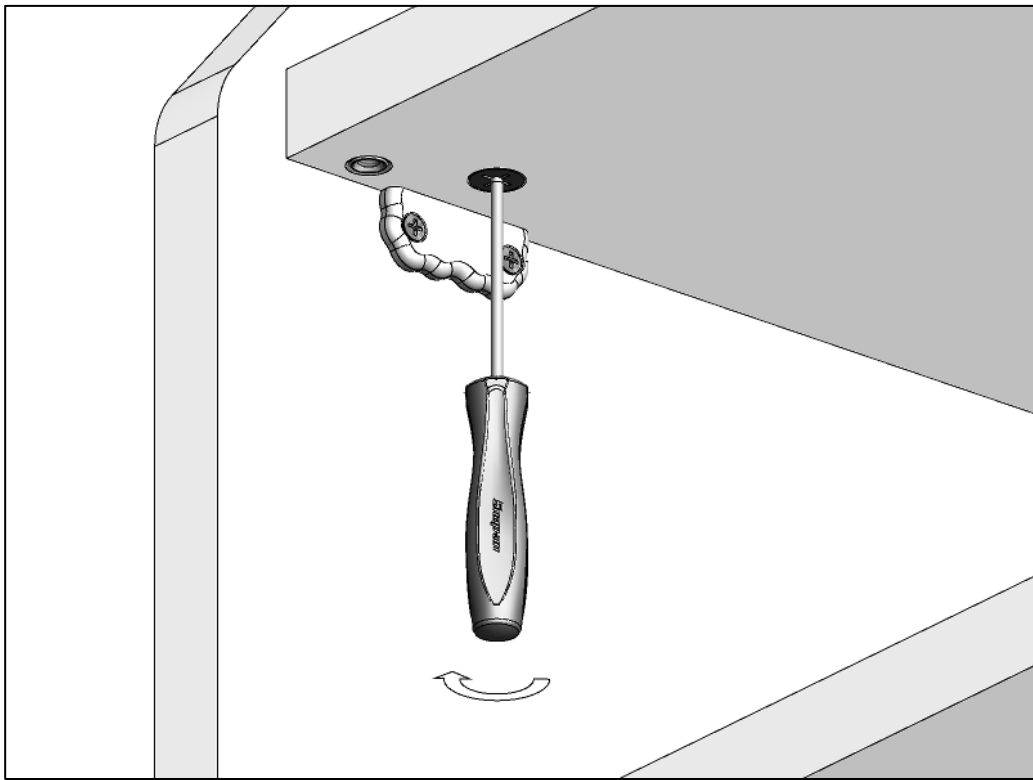
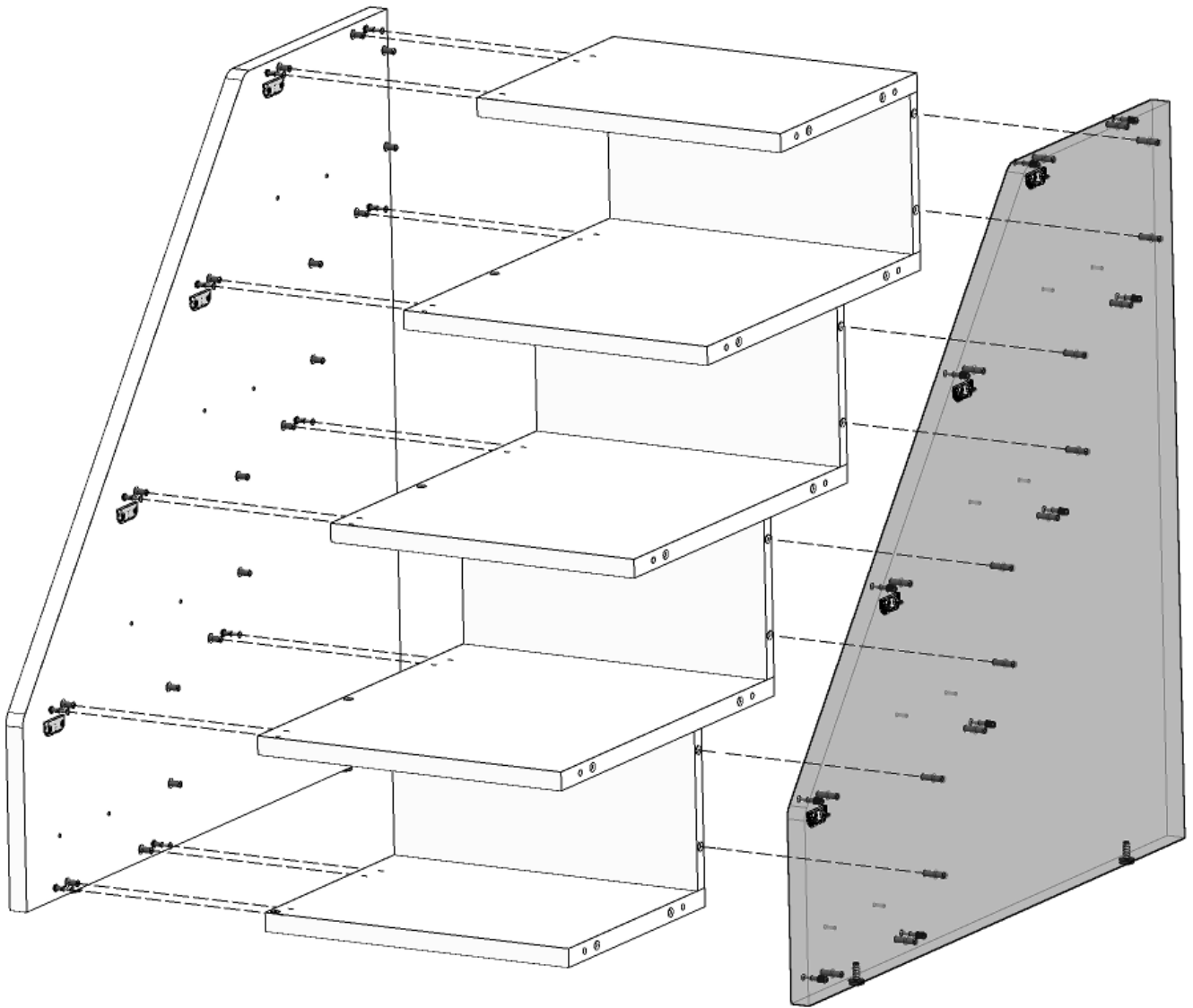

# VERSIONE CON CASSETTI

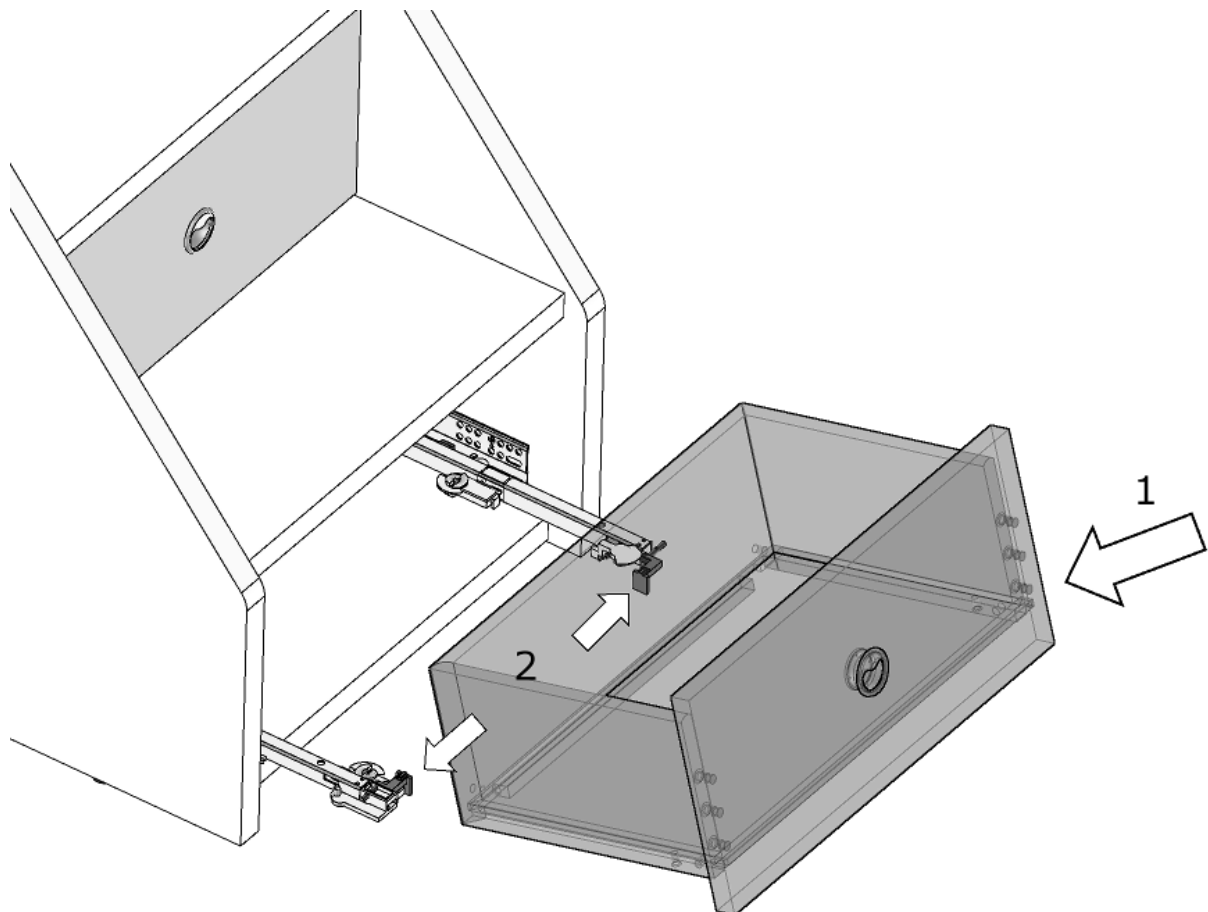
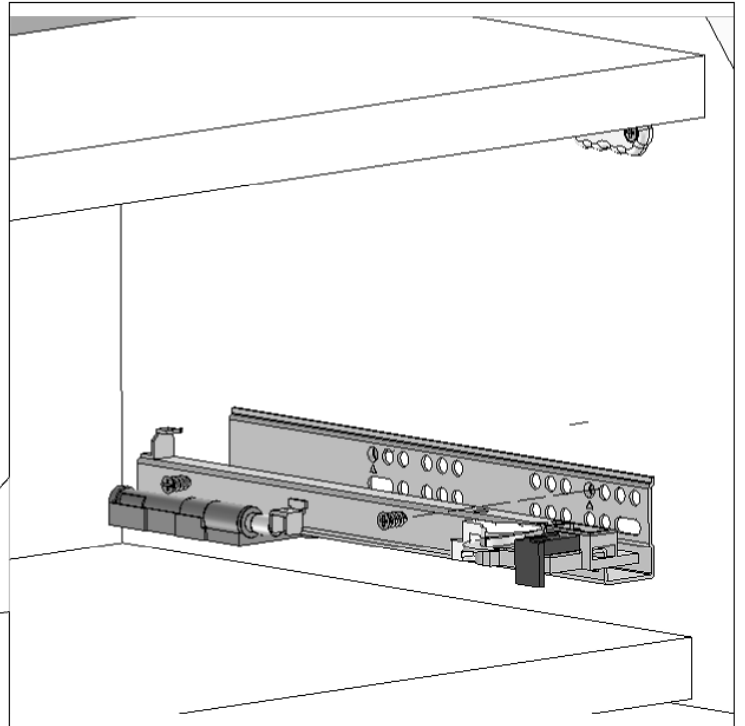
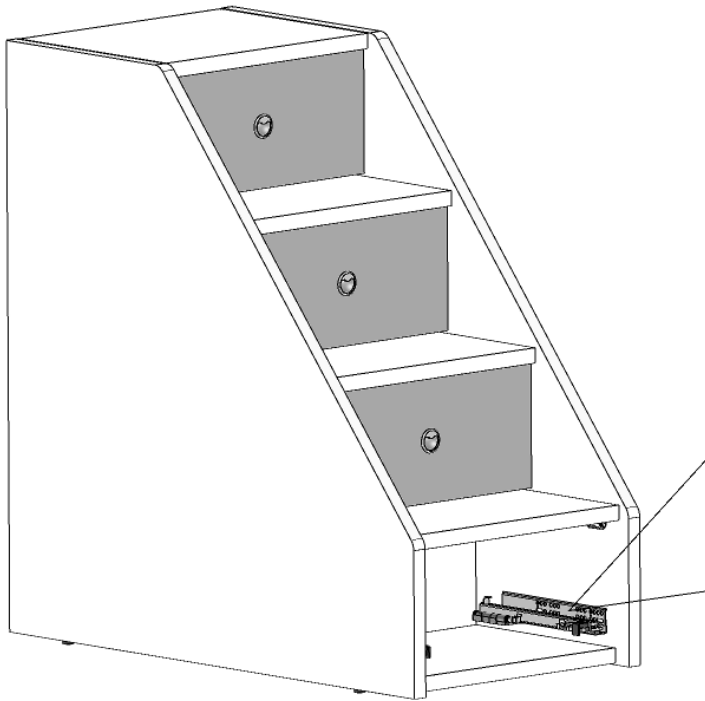



Ruotare la rotella nera verso il frontale del cassetto per aumentare l'aria tra il frontale e il fianco.

Questa operazione si effettua senza l'utilizzo di alcun utensile.

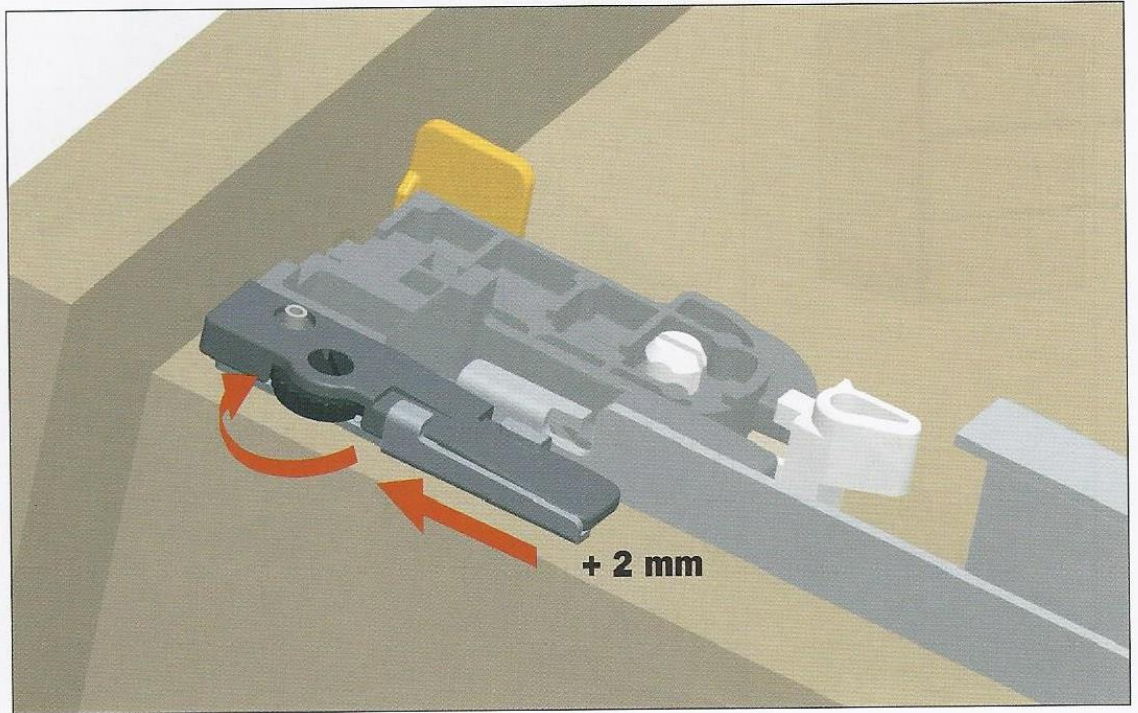
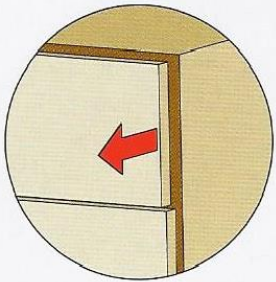
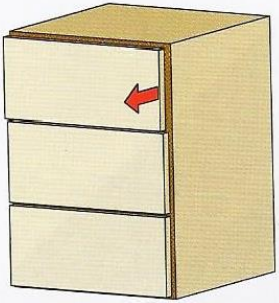

Ruotare la rotella nera verso il retro del cassetto per diminuire l'aria tra il frontale e il fianco.

Questa operazione si effettua senza l'utilizzo di alcun utensile.

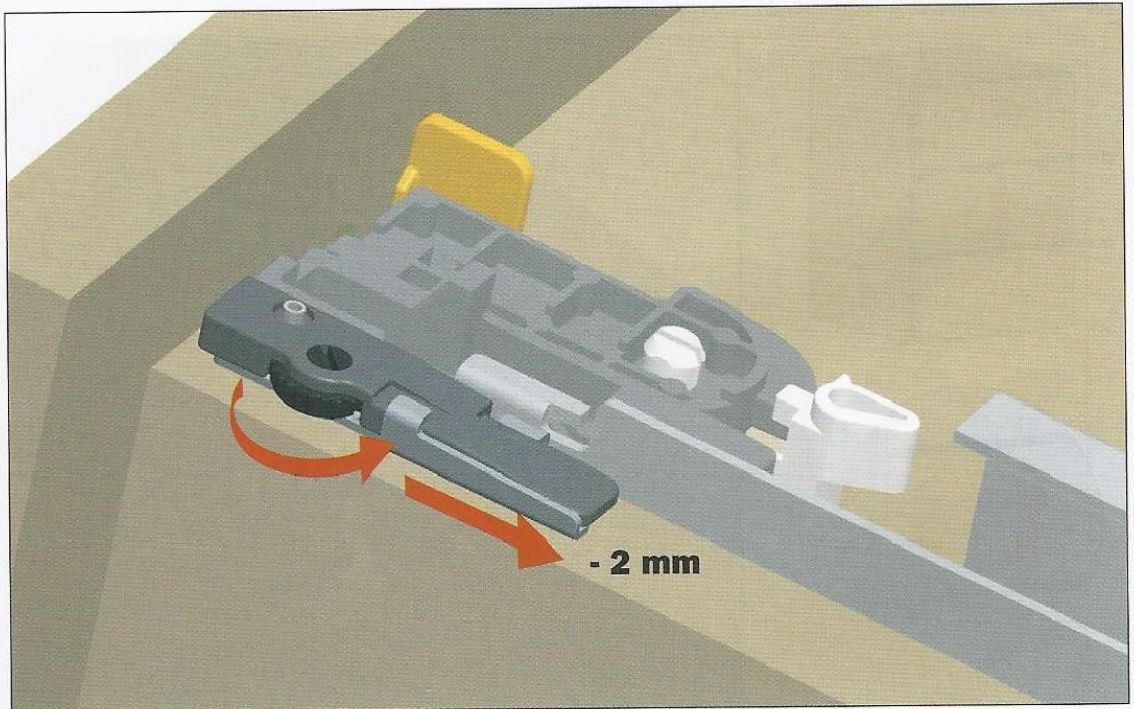
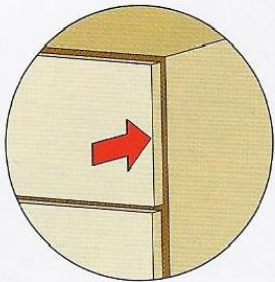
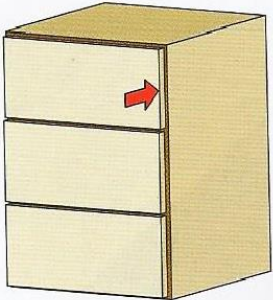

Posizione iniziale della leva per la regolazione verticale.

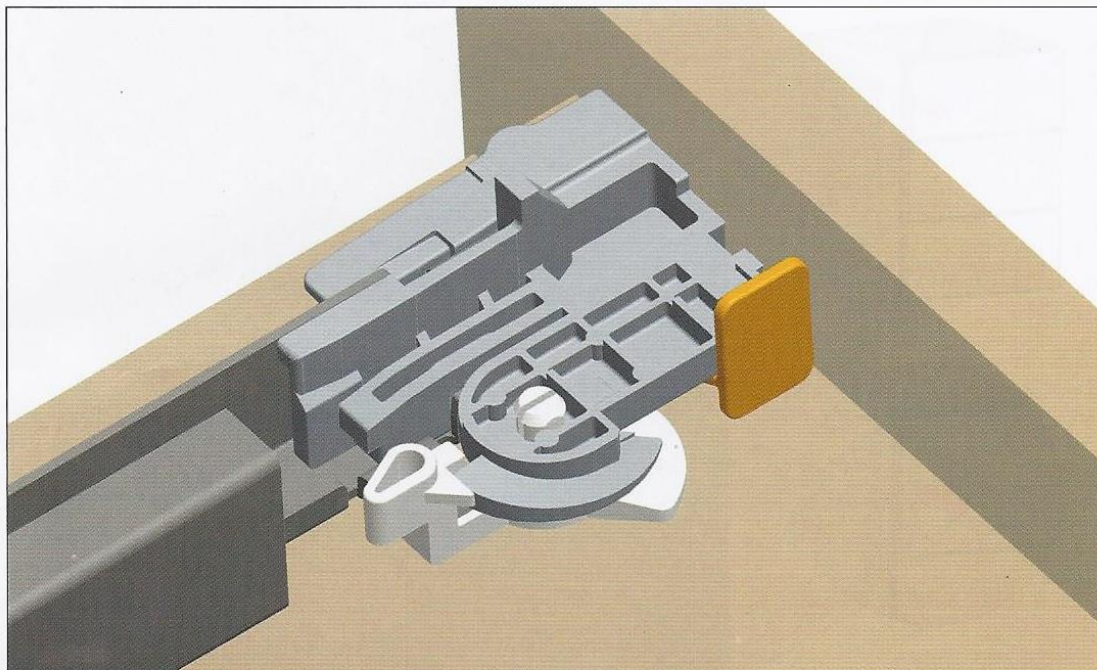
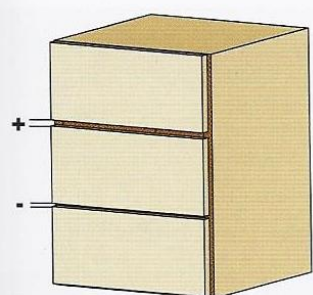

Ruotare la leva verso il frontale del cassetto per ottenere la regolazione verticale.

Questa operazione si effettua senza l'utilizzo di alcun utensile.

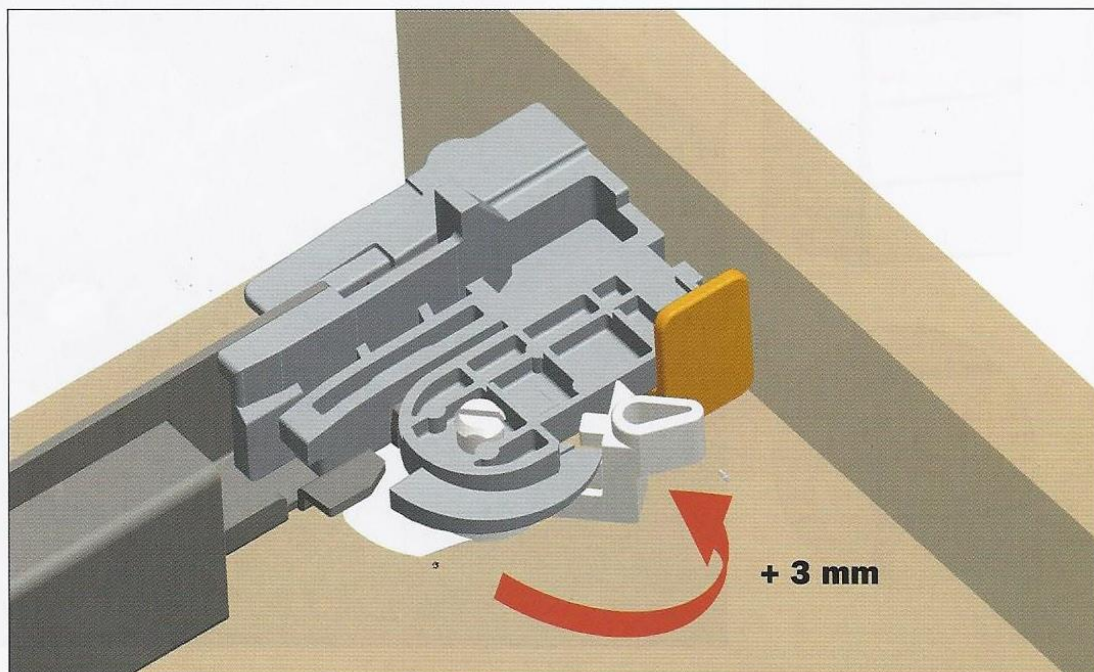
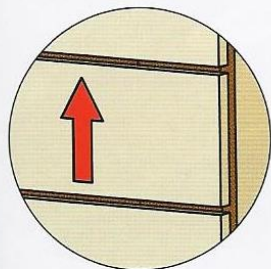
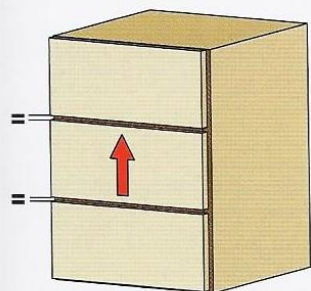

# VERSIONE CON ANTE

