

Schemi montaggio *Assembling diagrams*

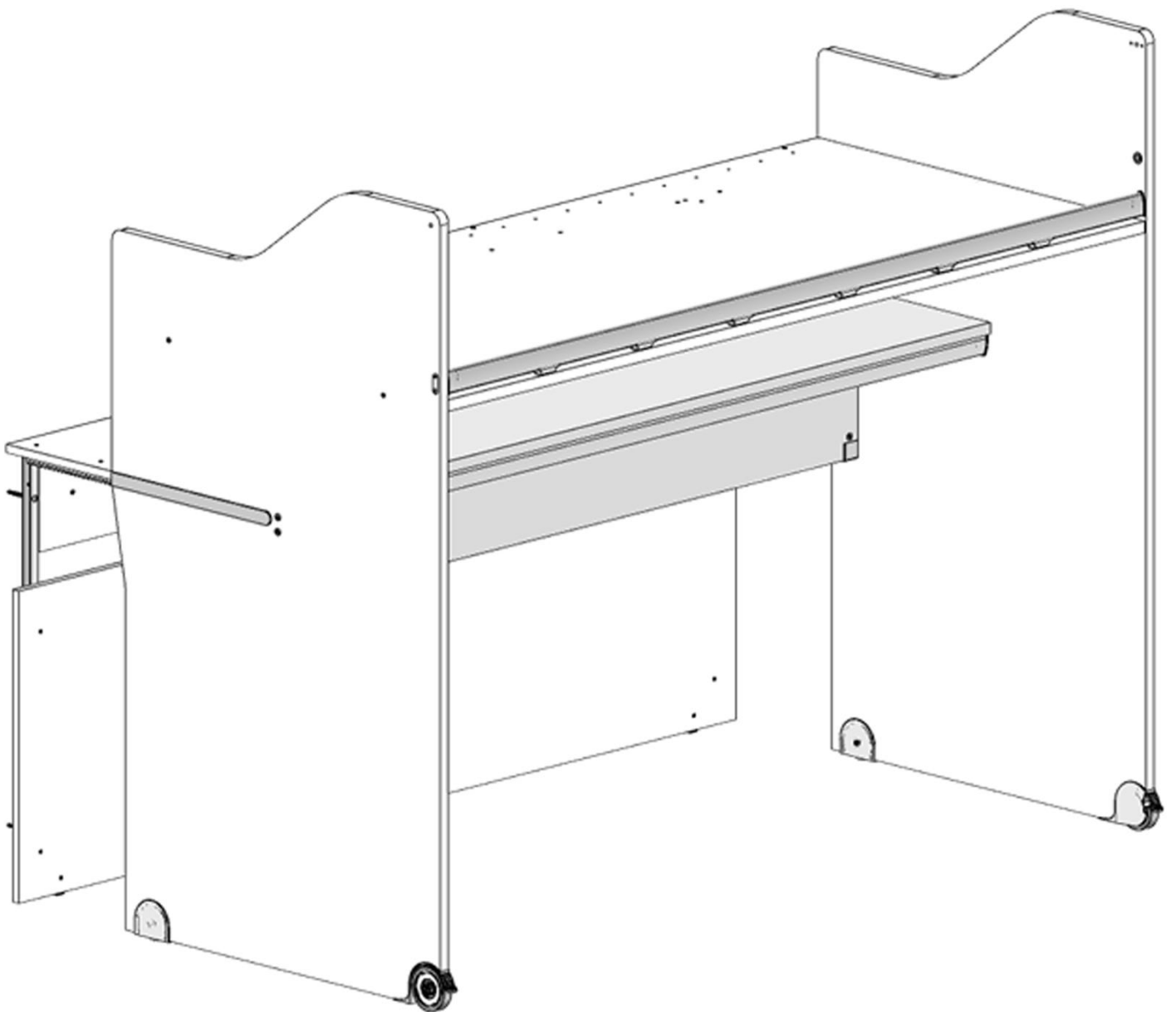







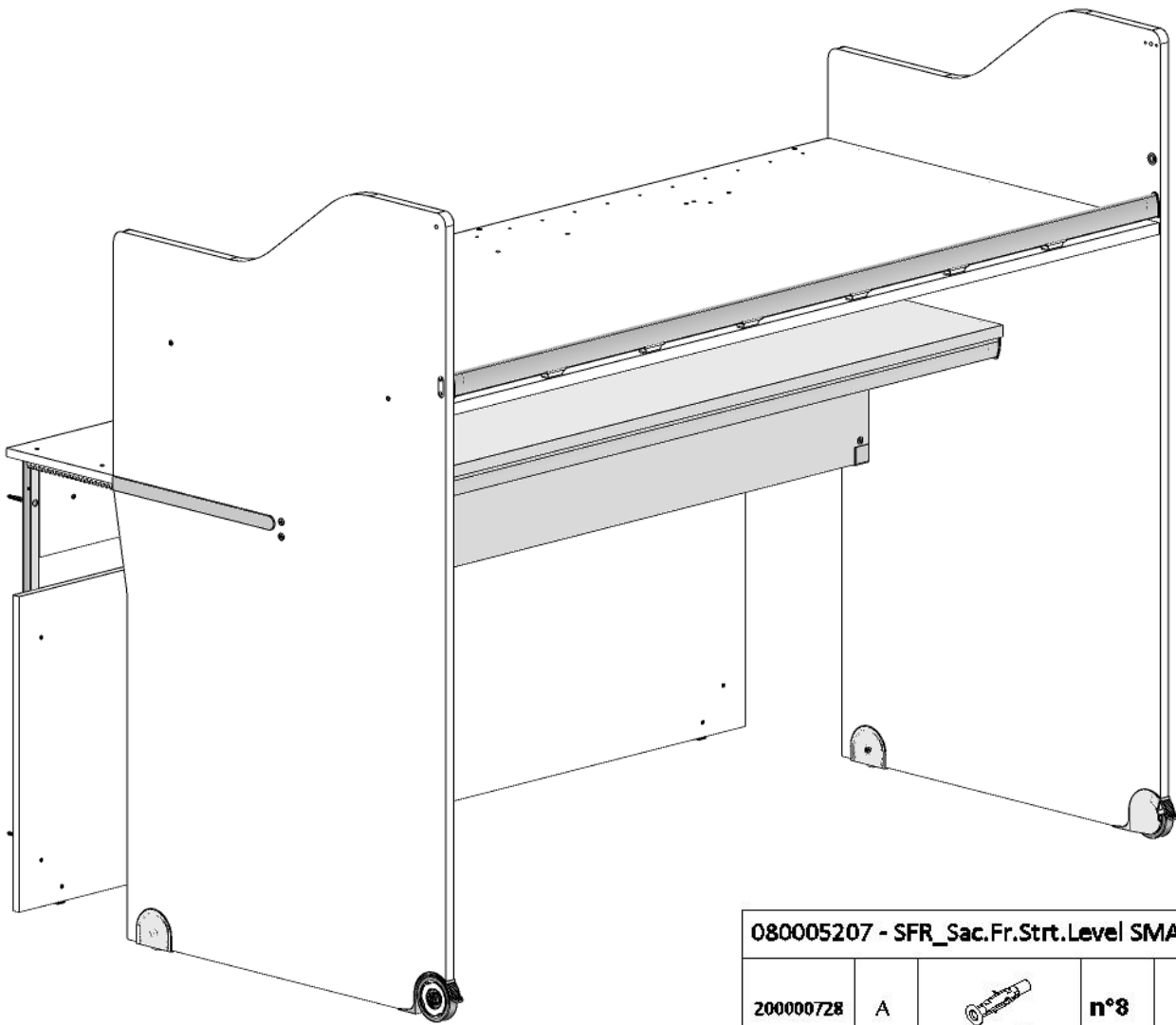

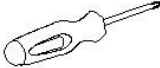

LEVEL SMART

ed. 02/2016 - rev. 1















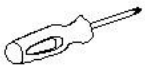





SCMNT021

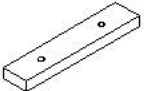

080005206 - SFR_Sac.Fr.Mecc.Apert.LvlSMART

200001064	T		n°1	
200002017	U		n°3	
200001760	V		n°2	
200000910	W		n°2	
200000895	X		n°1	
200000976	Y		n°2	
200001065	Z		n°1	

080005207 - SFR_Sac.Fr.Strt.Level SMART 2

200000728	A		n°8	
200000964	B		n°4	
200000667	C		n°4	
200000941	D		n°4	
200000966	E		n°4	
200000653	F		n°8	
200000666	G		n°8	
200000940	H		n°4	
200000906	I		n°4	
200000951	J		n°4	
200000876	K		n°3	
200000907	L		n°3	
200001759	M		n°1	
200000938	N		n°2	
200001219	O		n°2	
200000872	P		n°4	
200000973	Q		n°4	
200000959	R		n°6	
200000996	S		n°4	

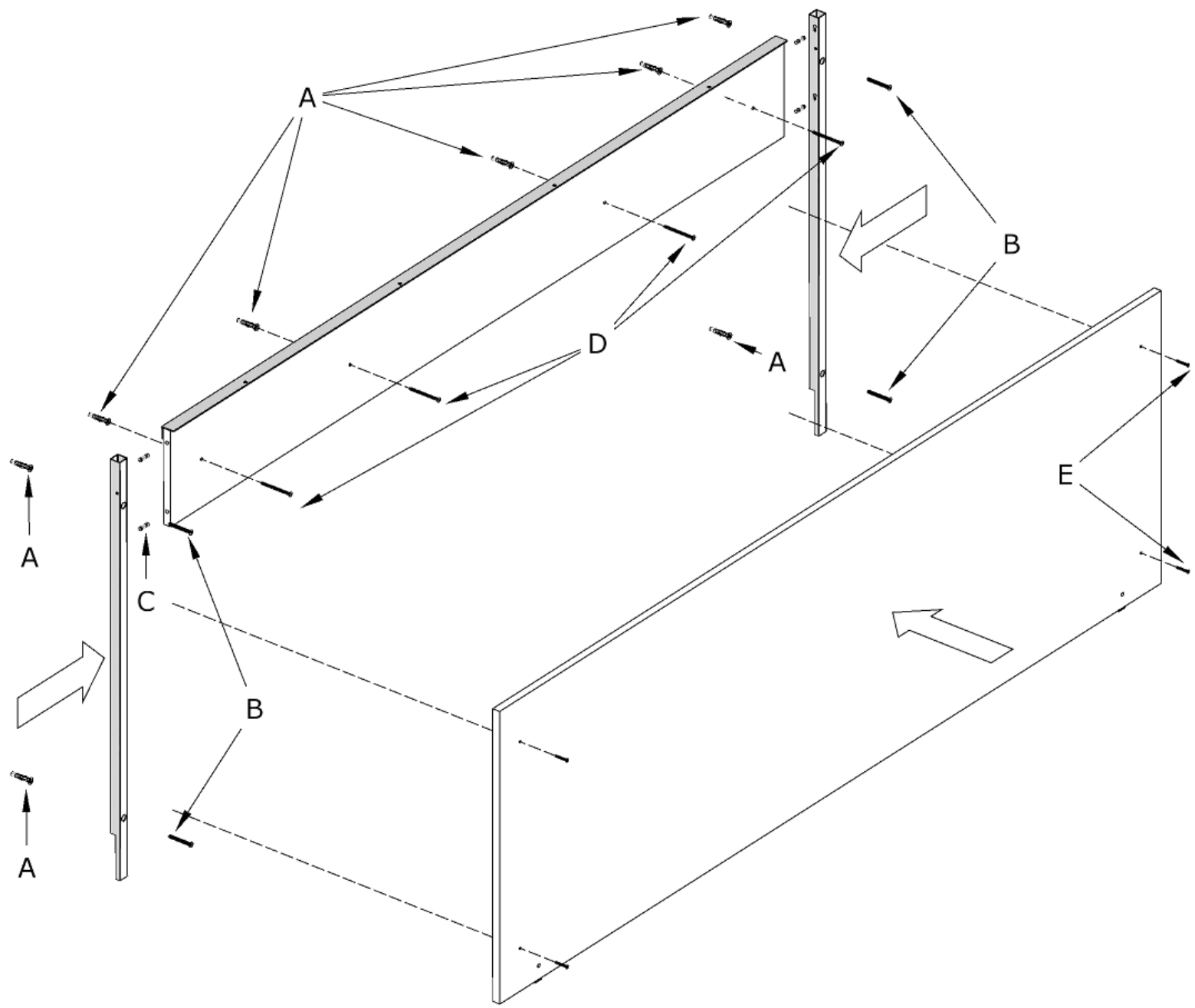

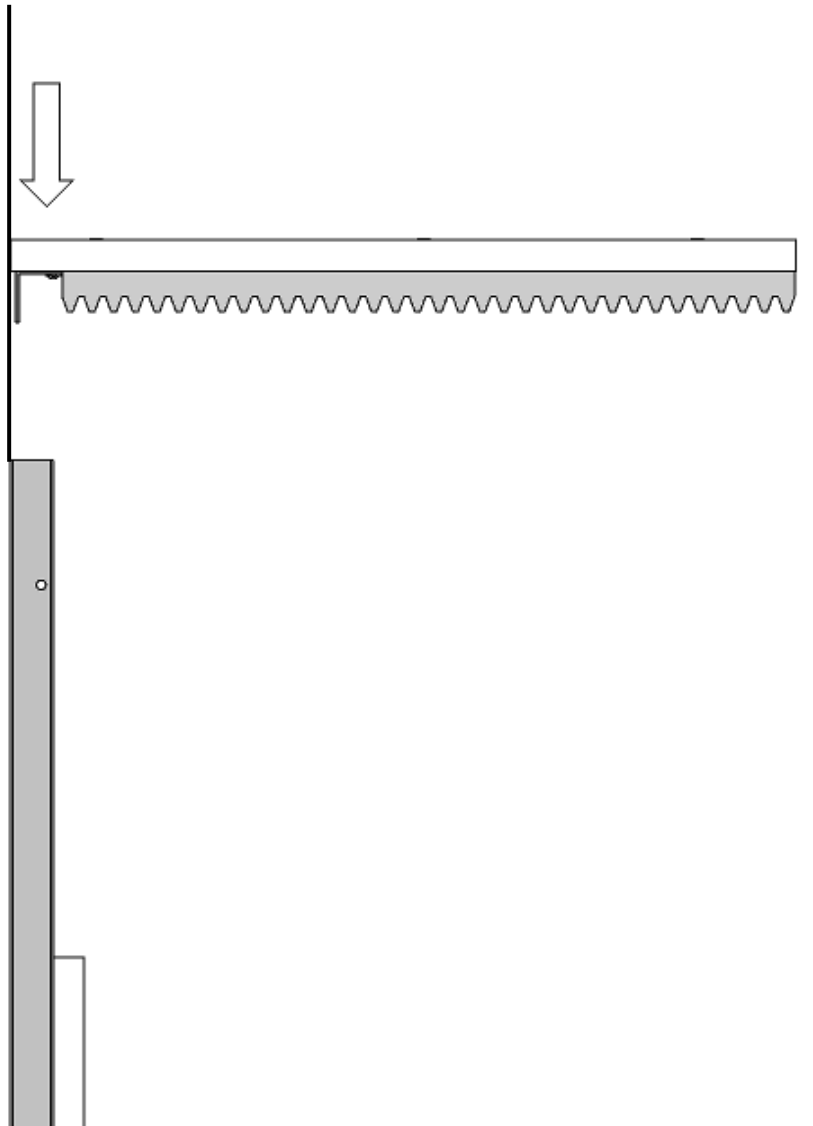
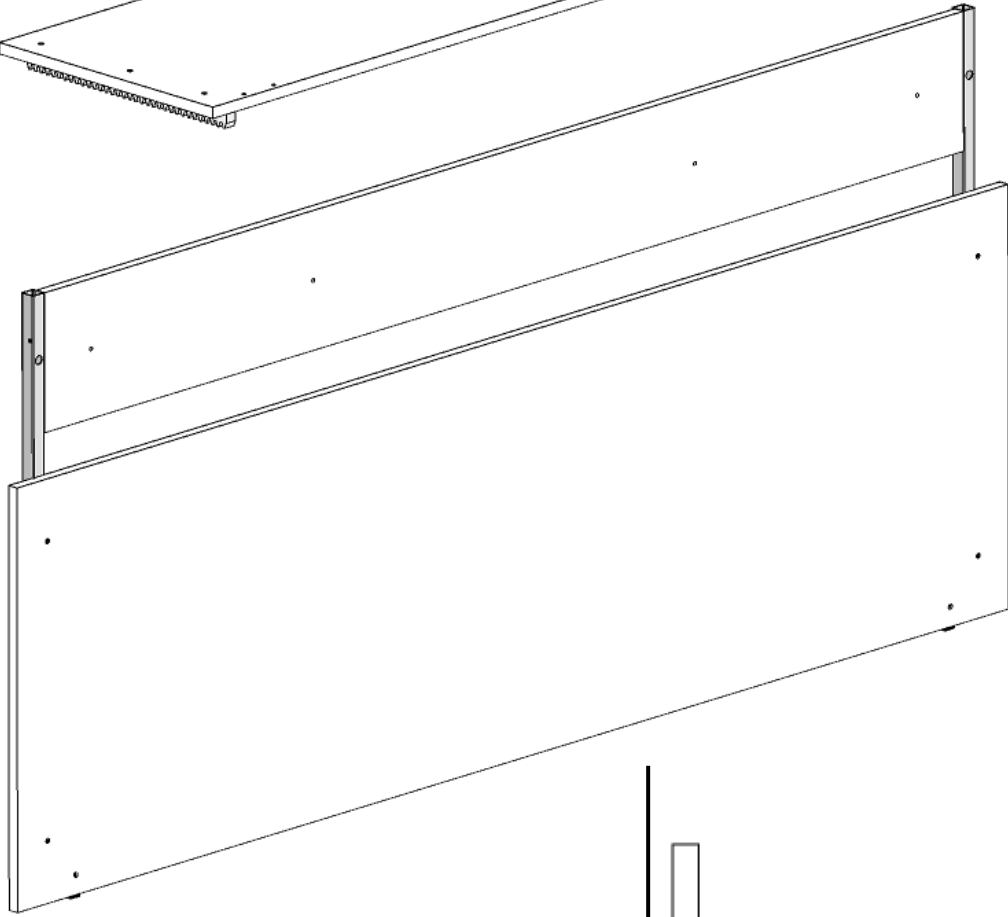
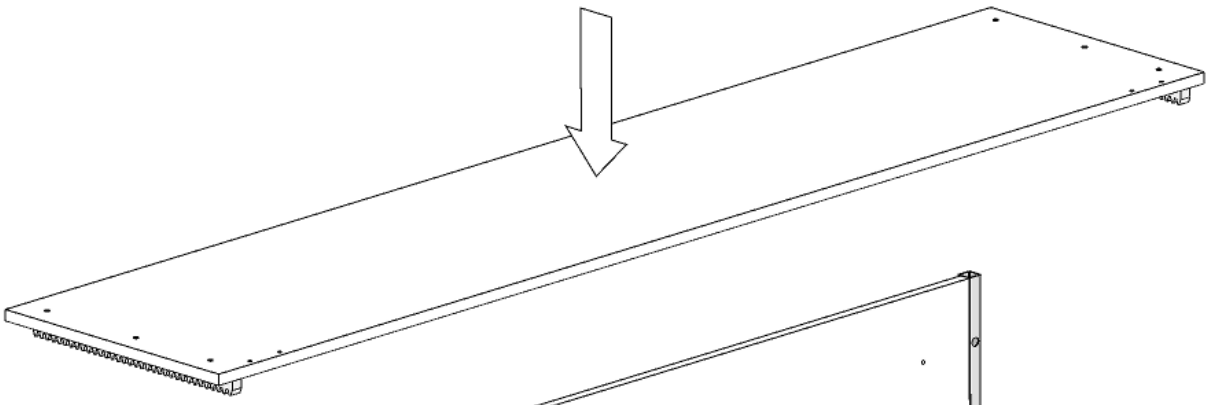

PARETE

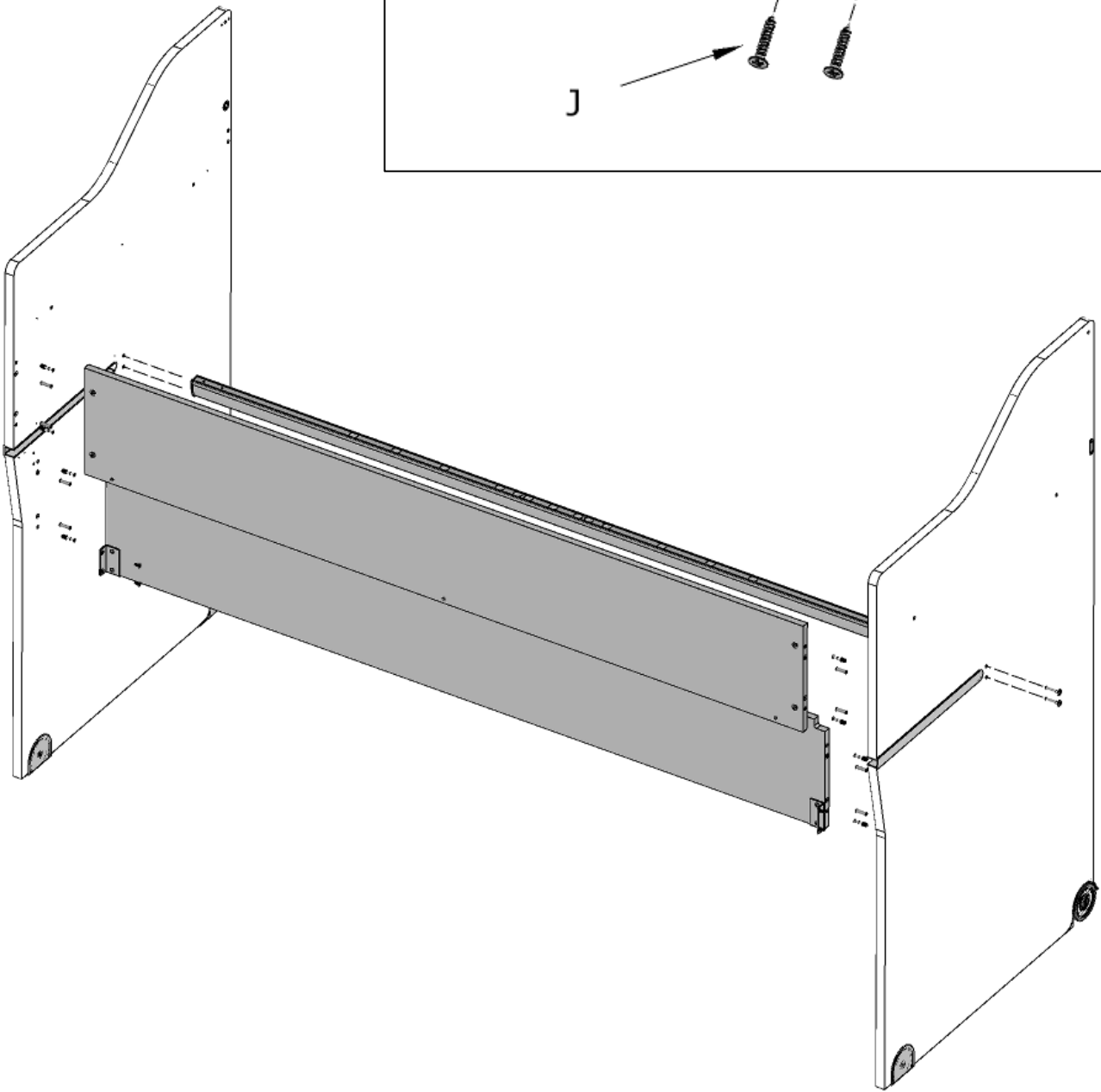
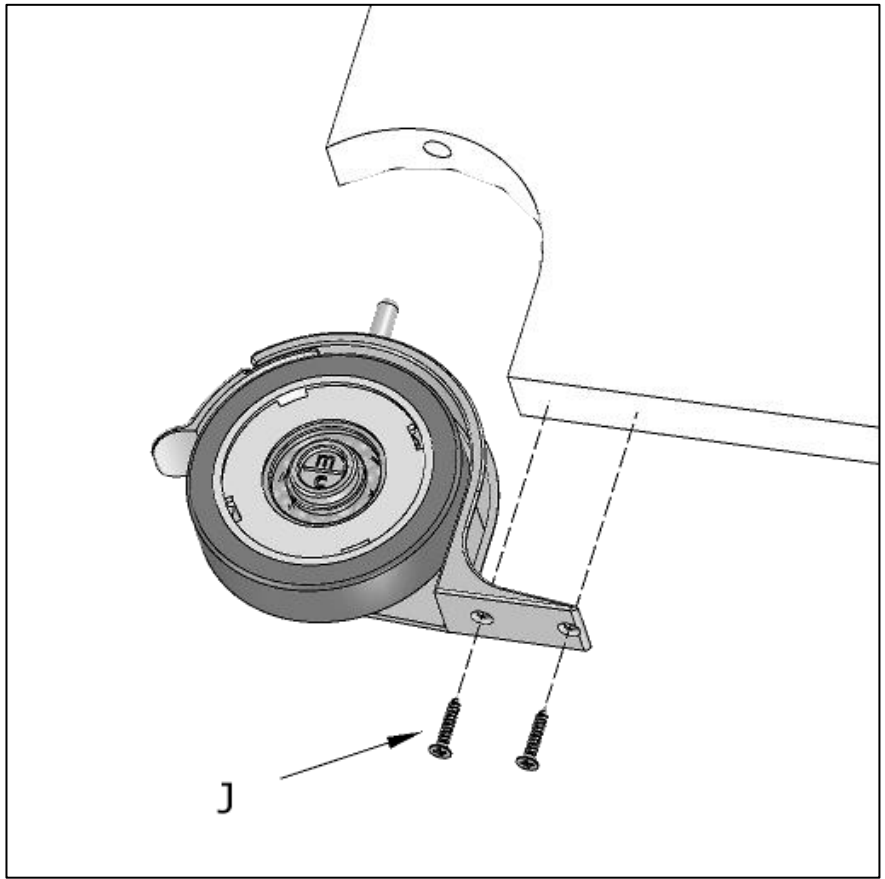

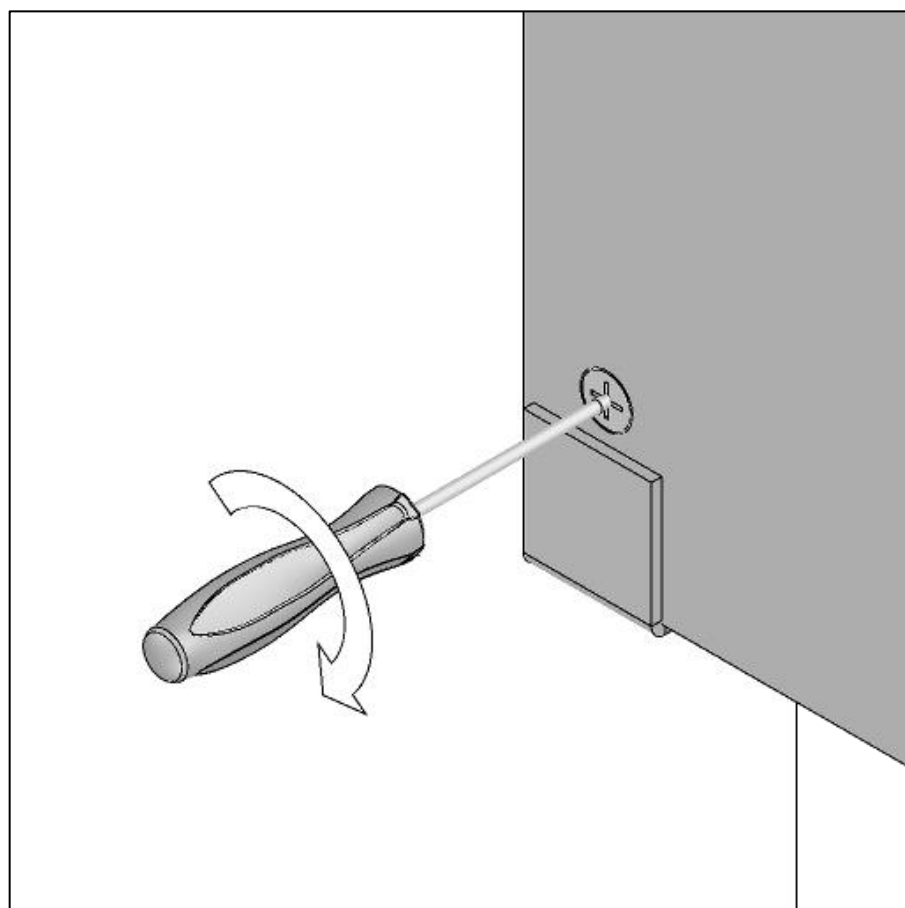
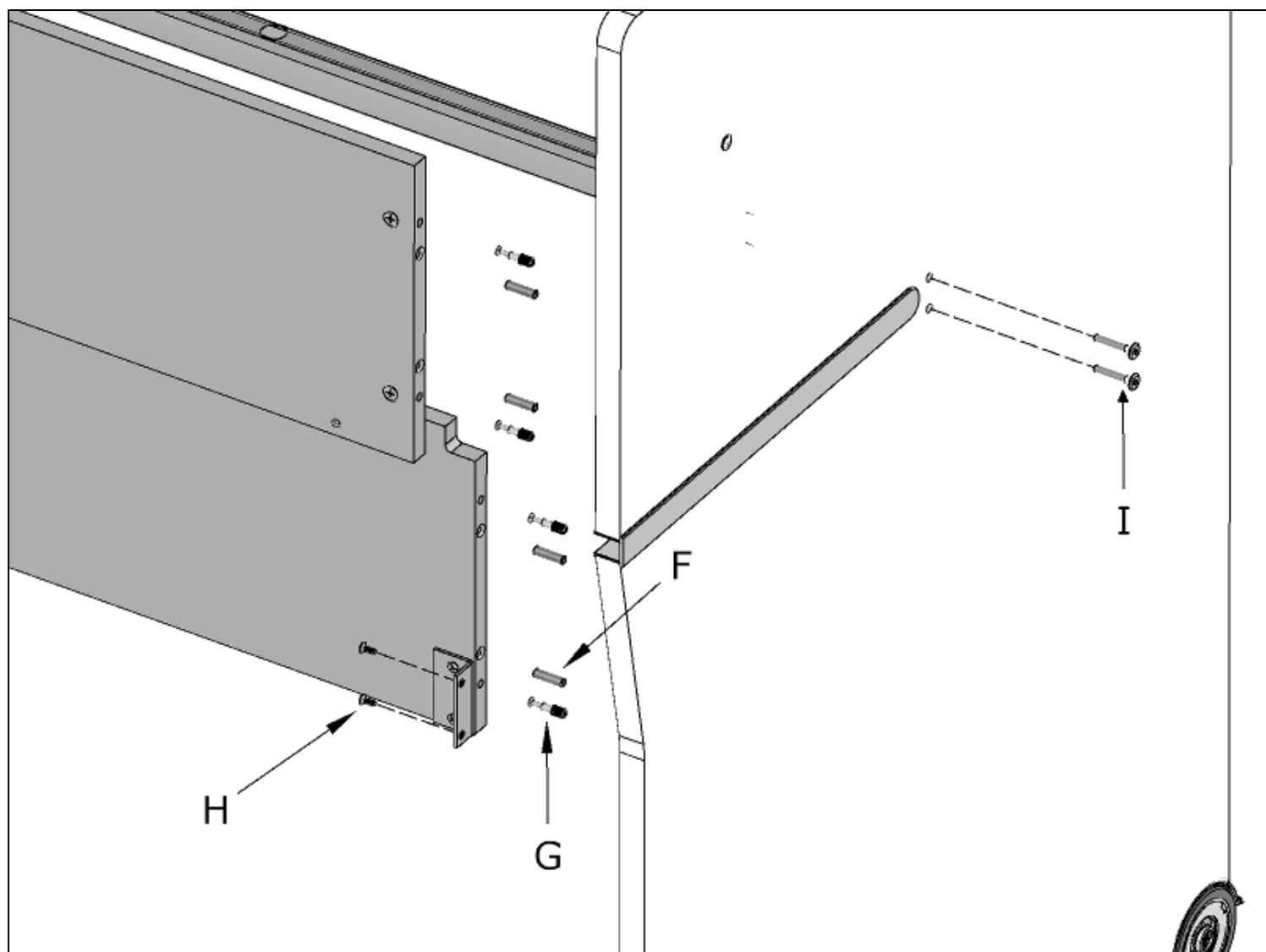

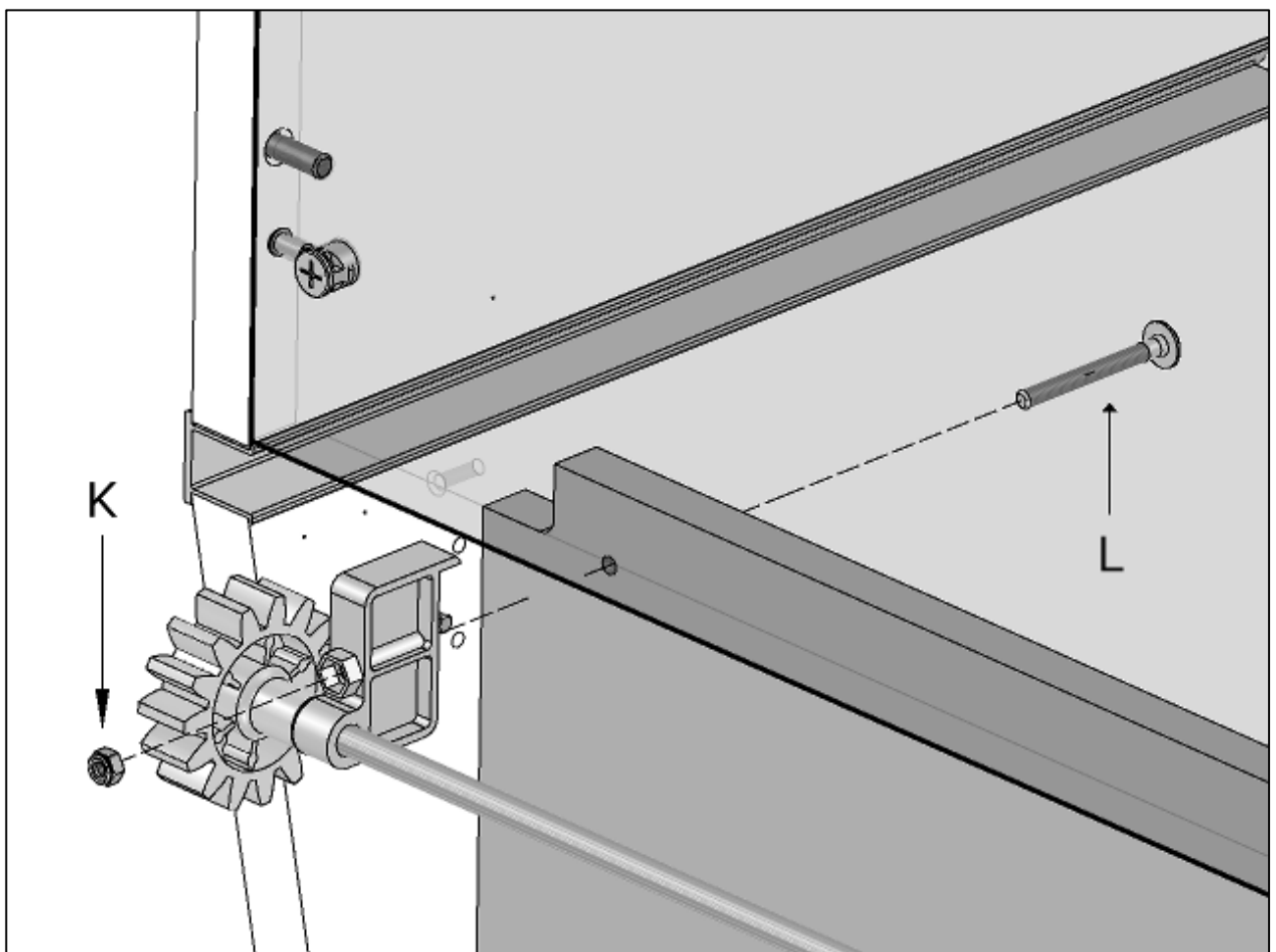
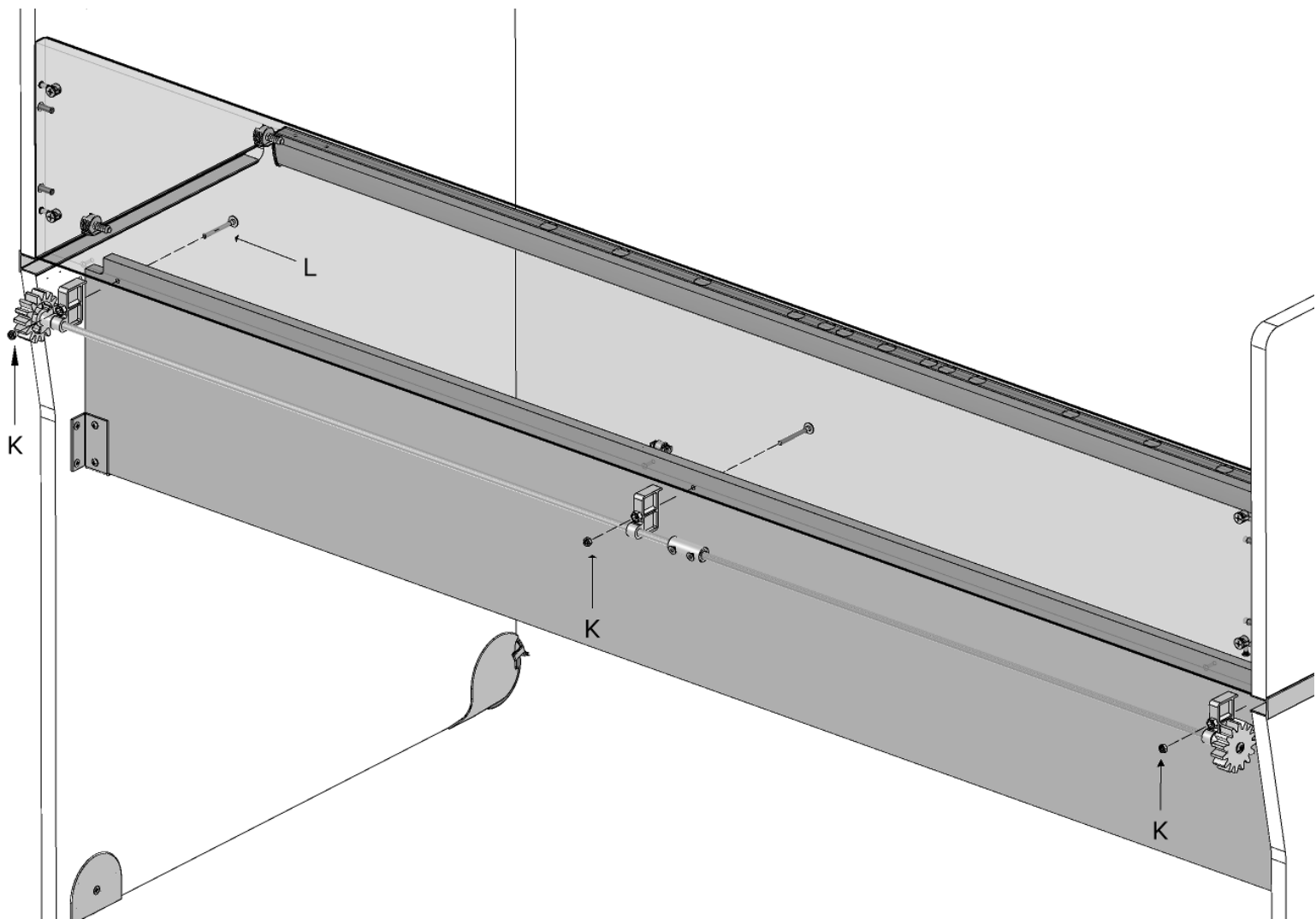

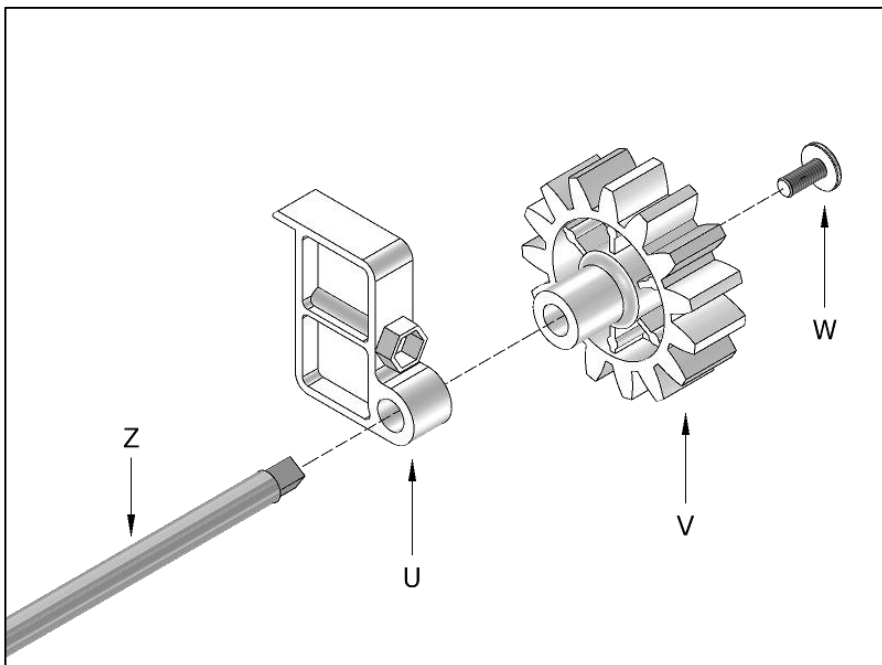
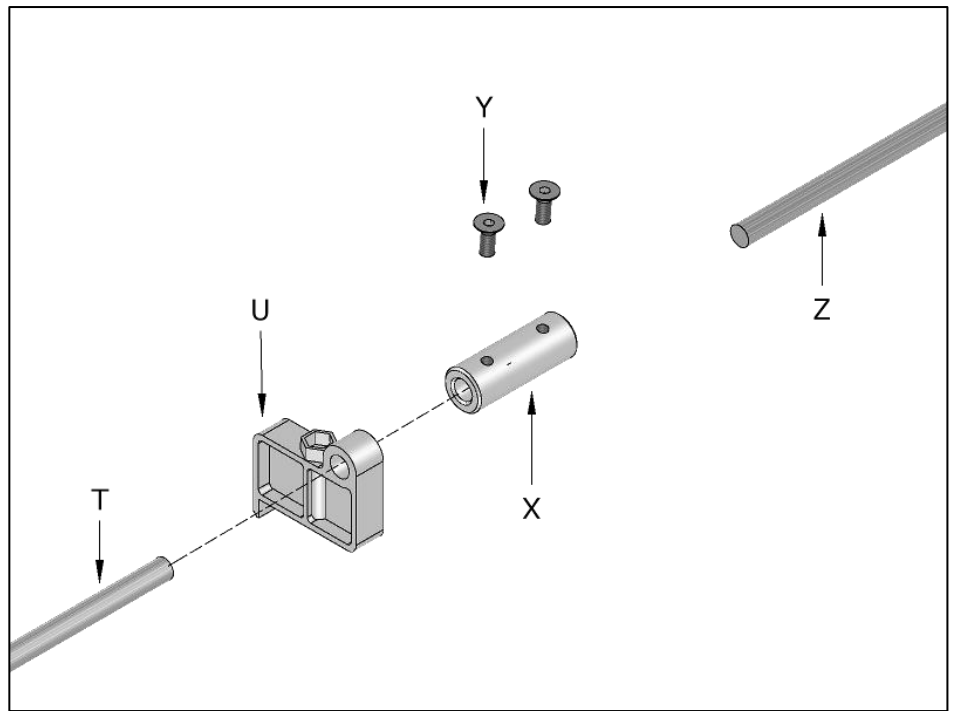
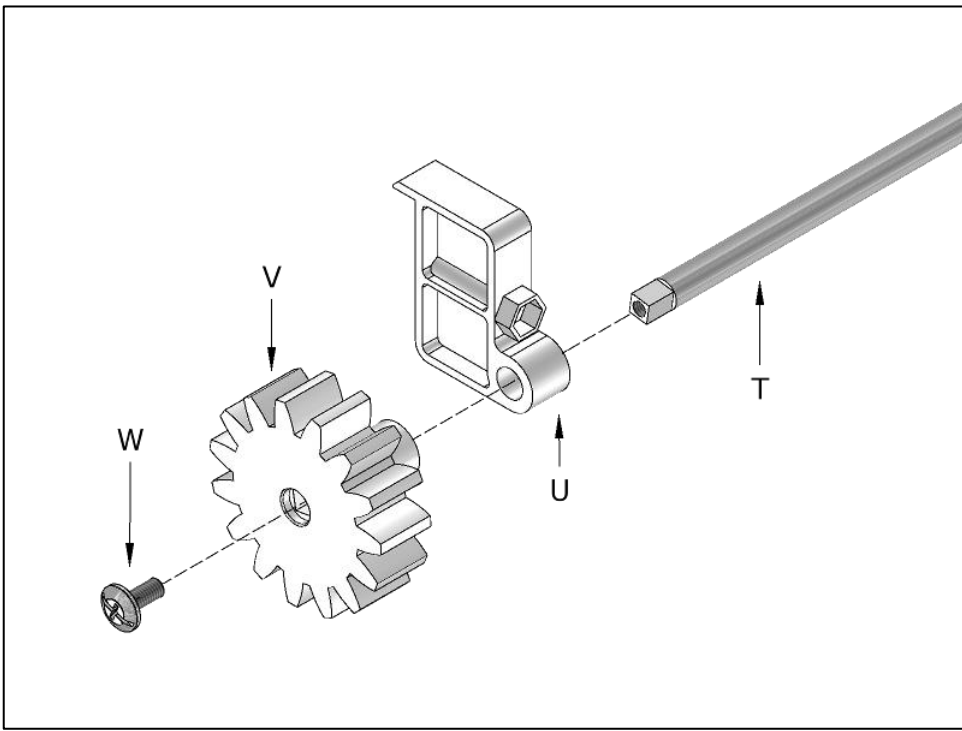

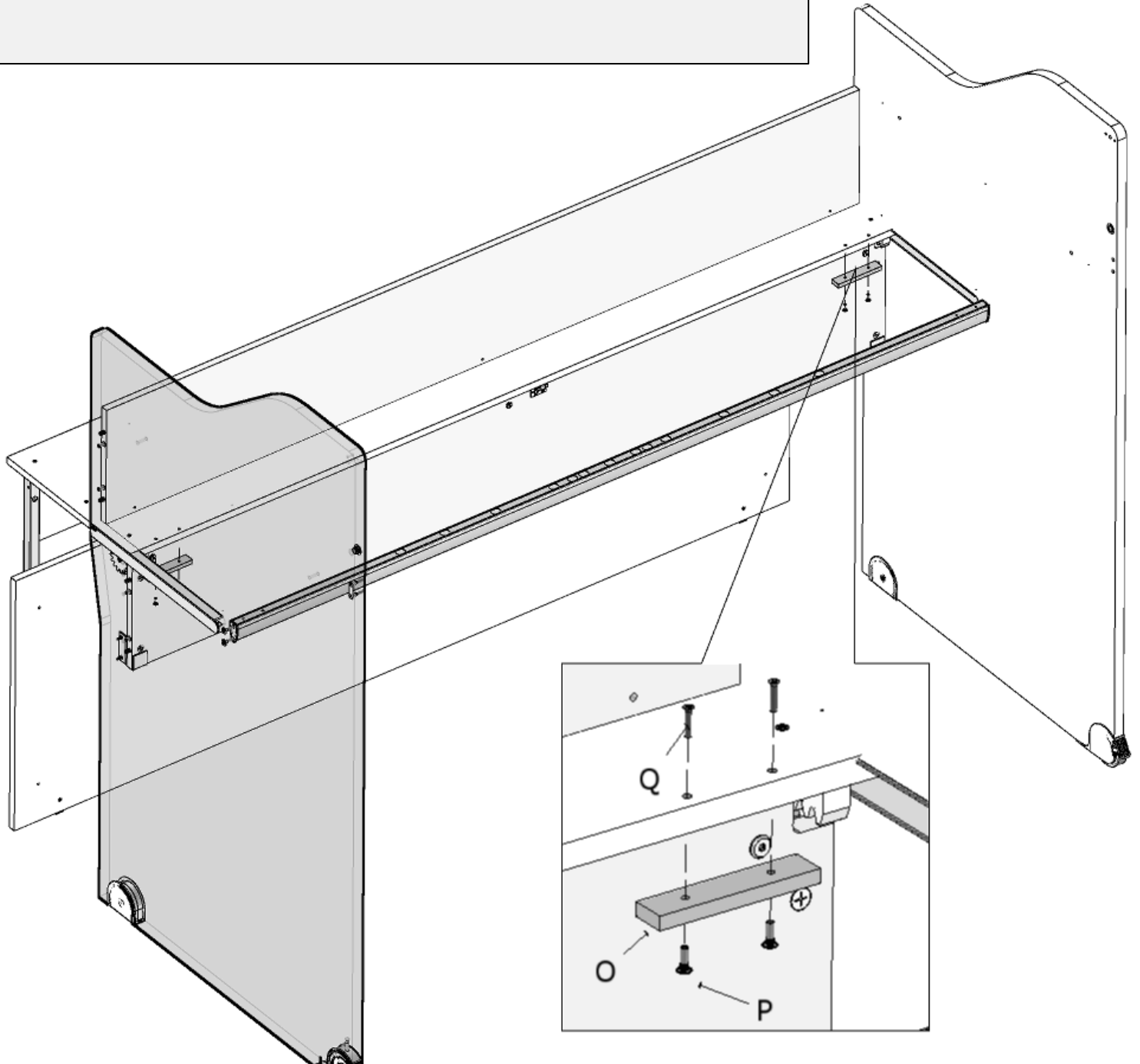
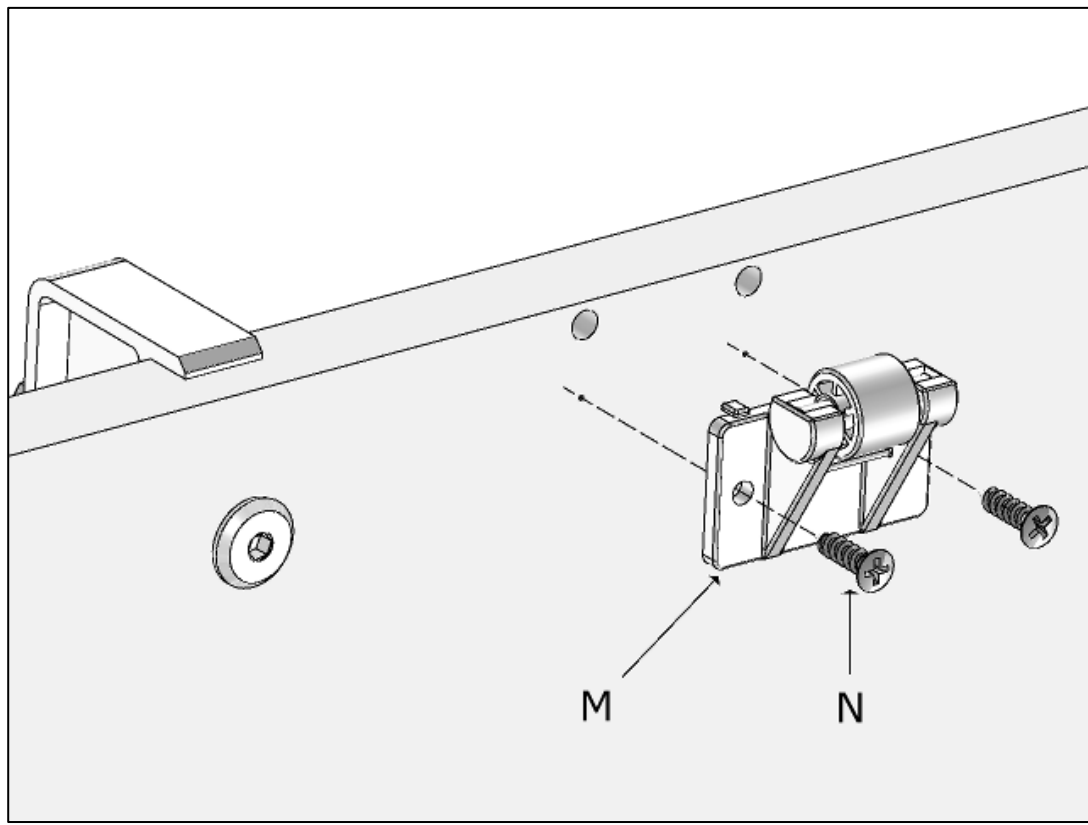

ESTRARRE COMPLETAMENTE IL
SOPPALCO E SERRARE I GRANI
CON L' APPOSITA CHIAVE PER
FASARE LA STRUTTURA

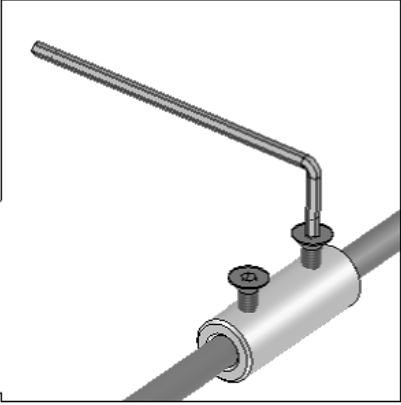
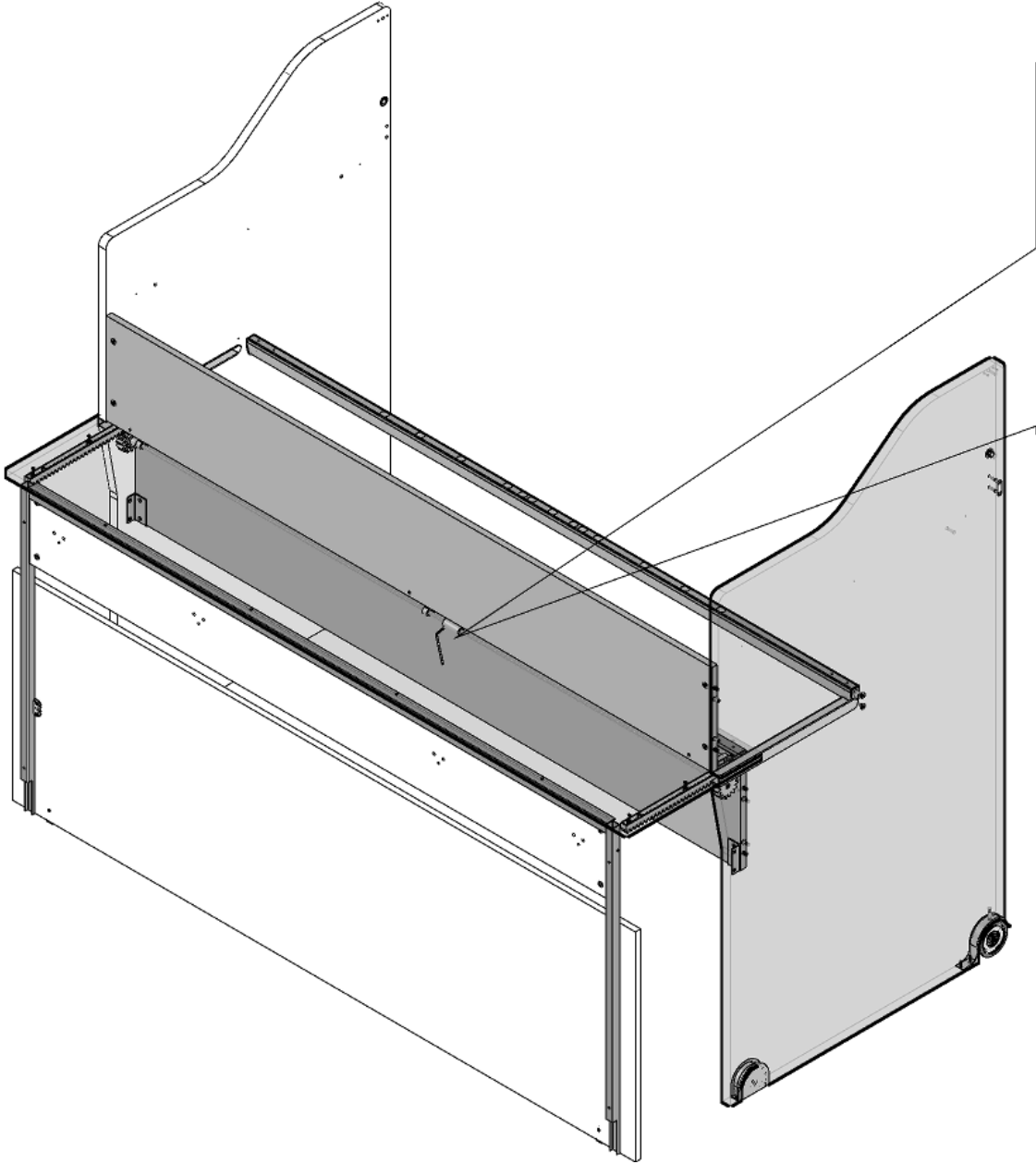

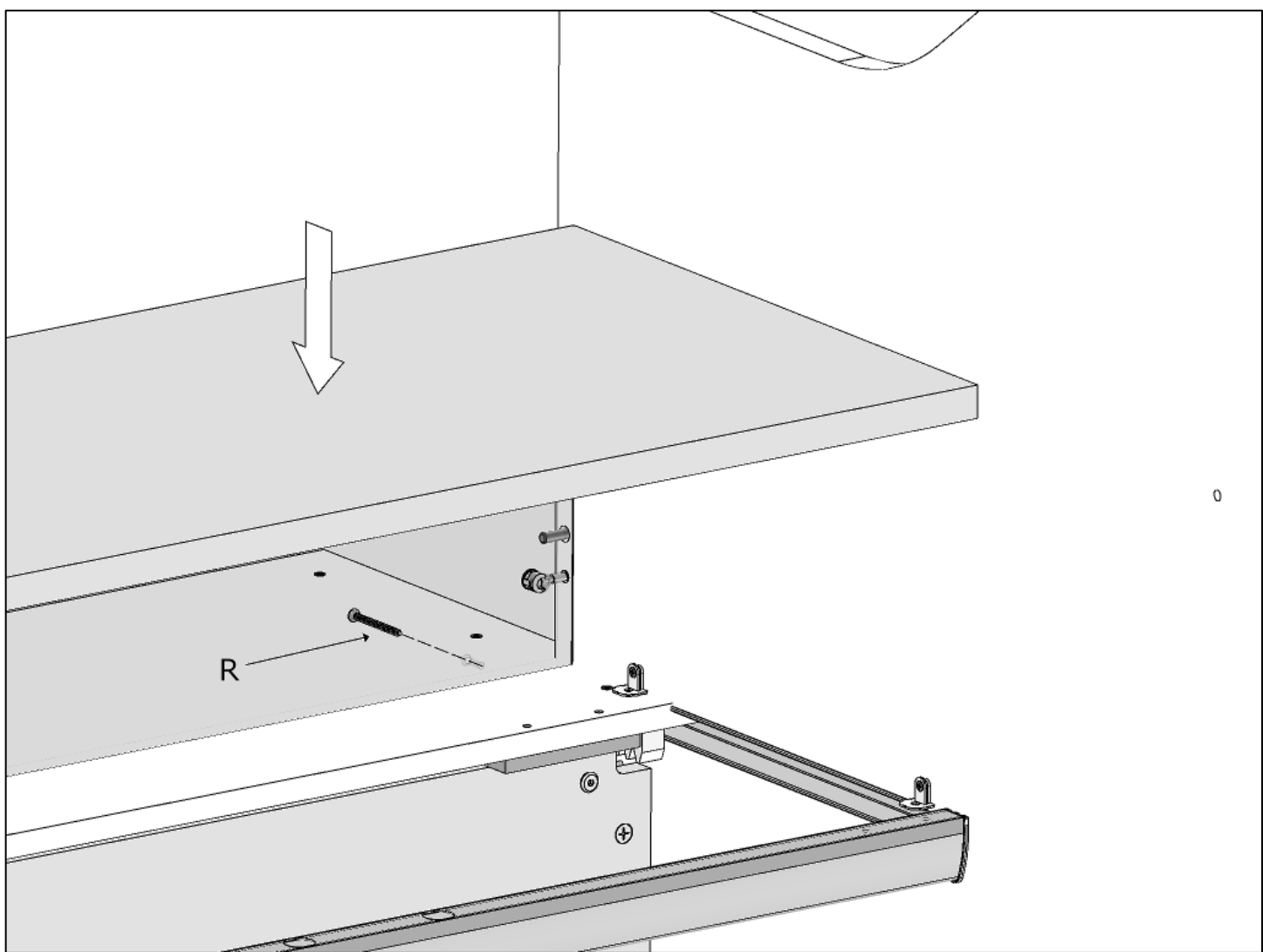
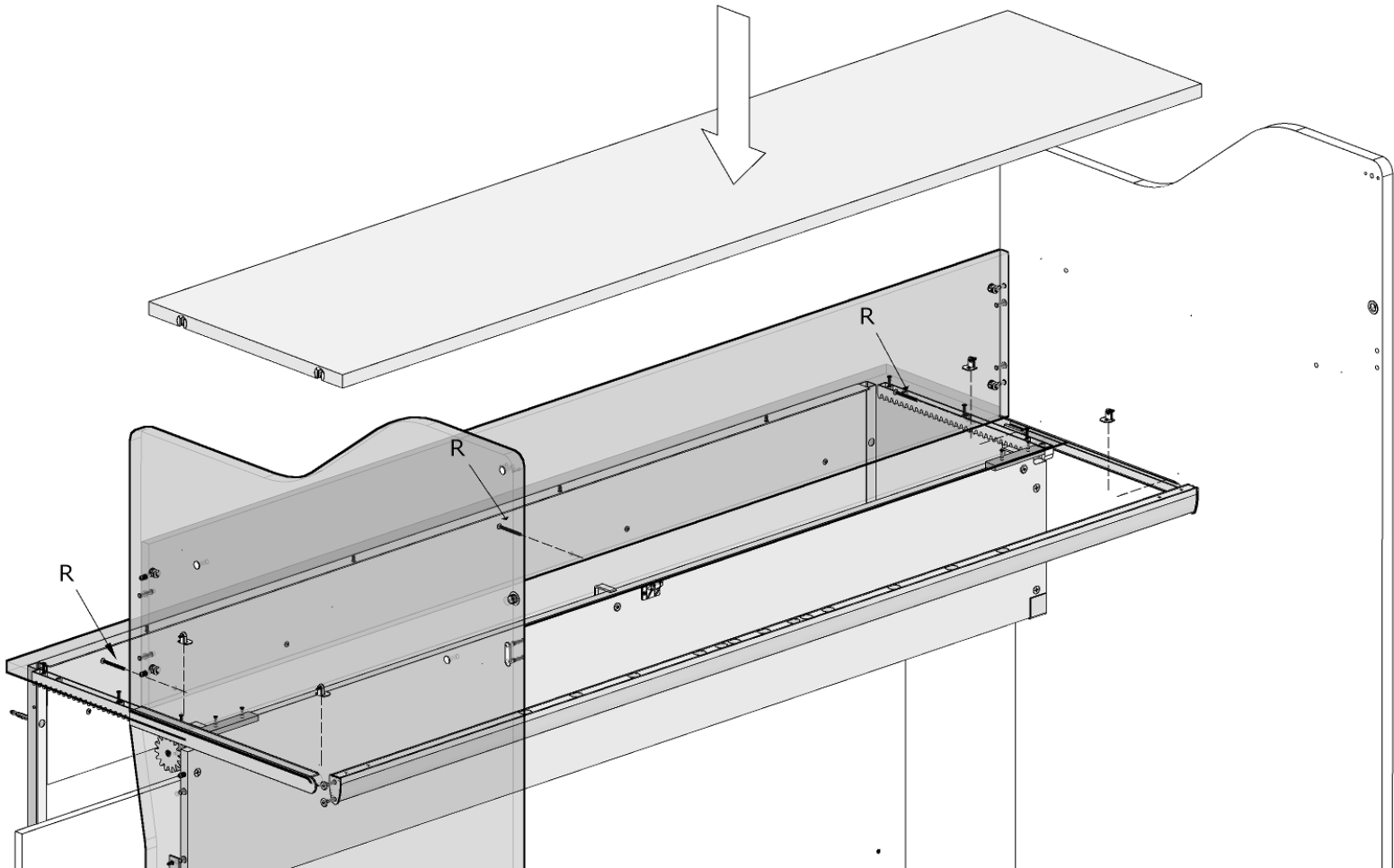

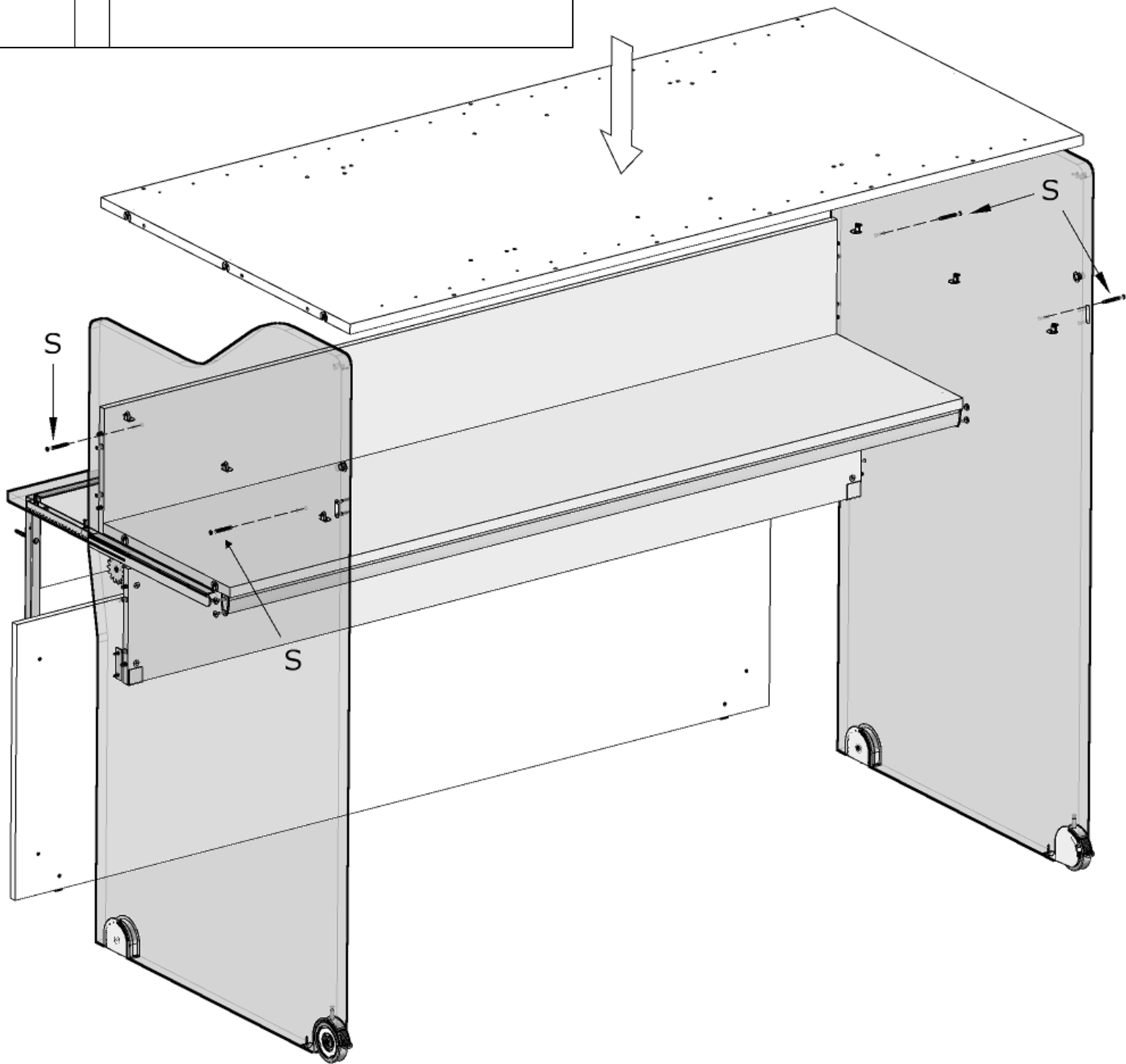
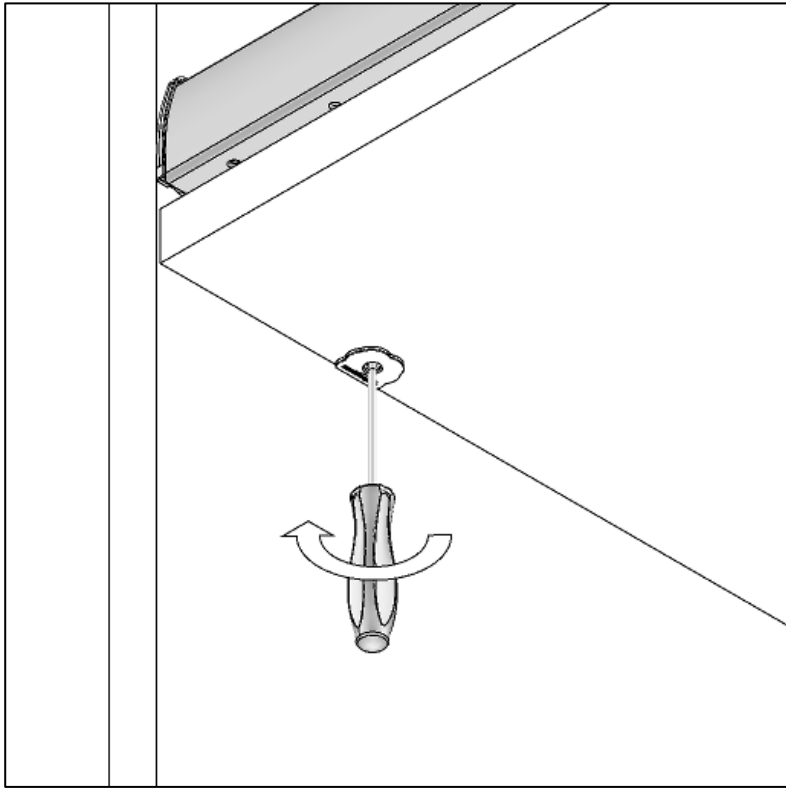

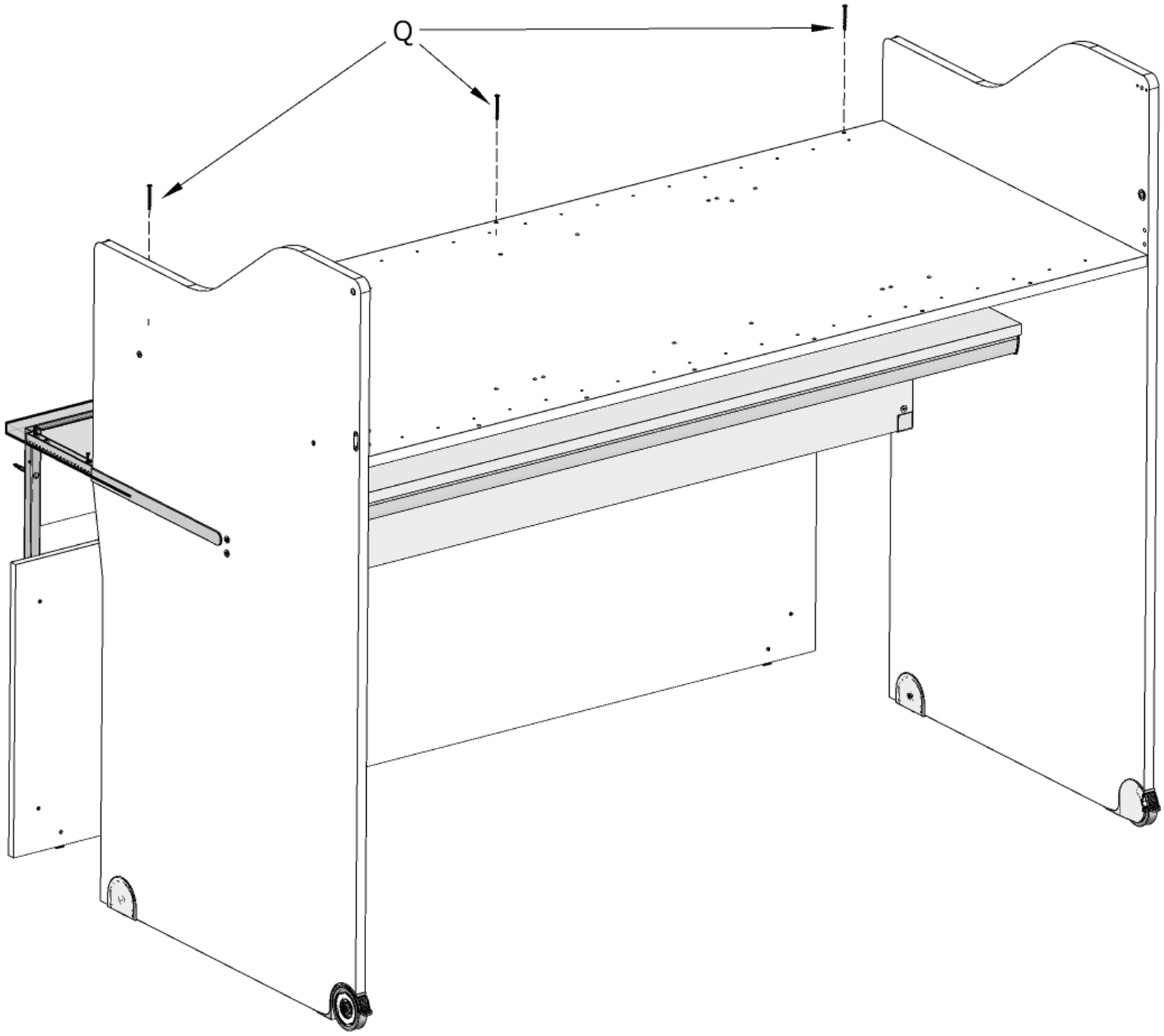

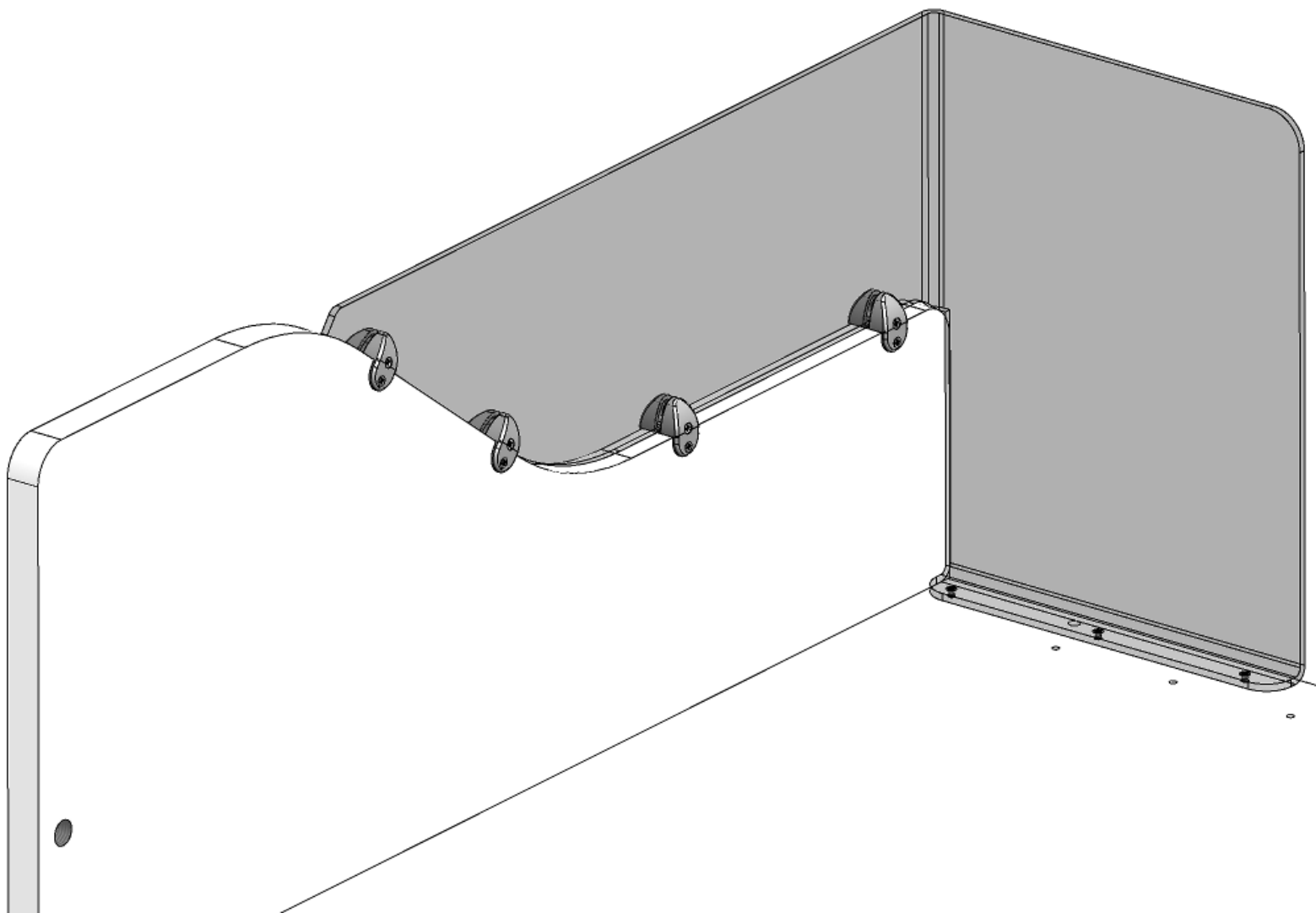



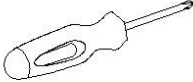
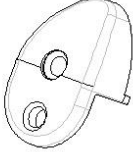

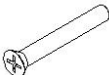

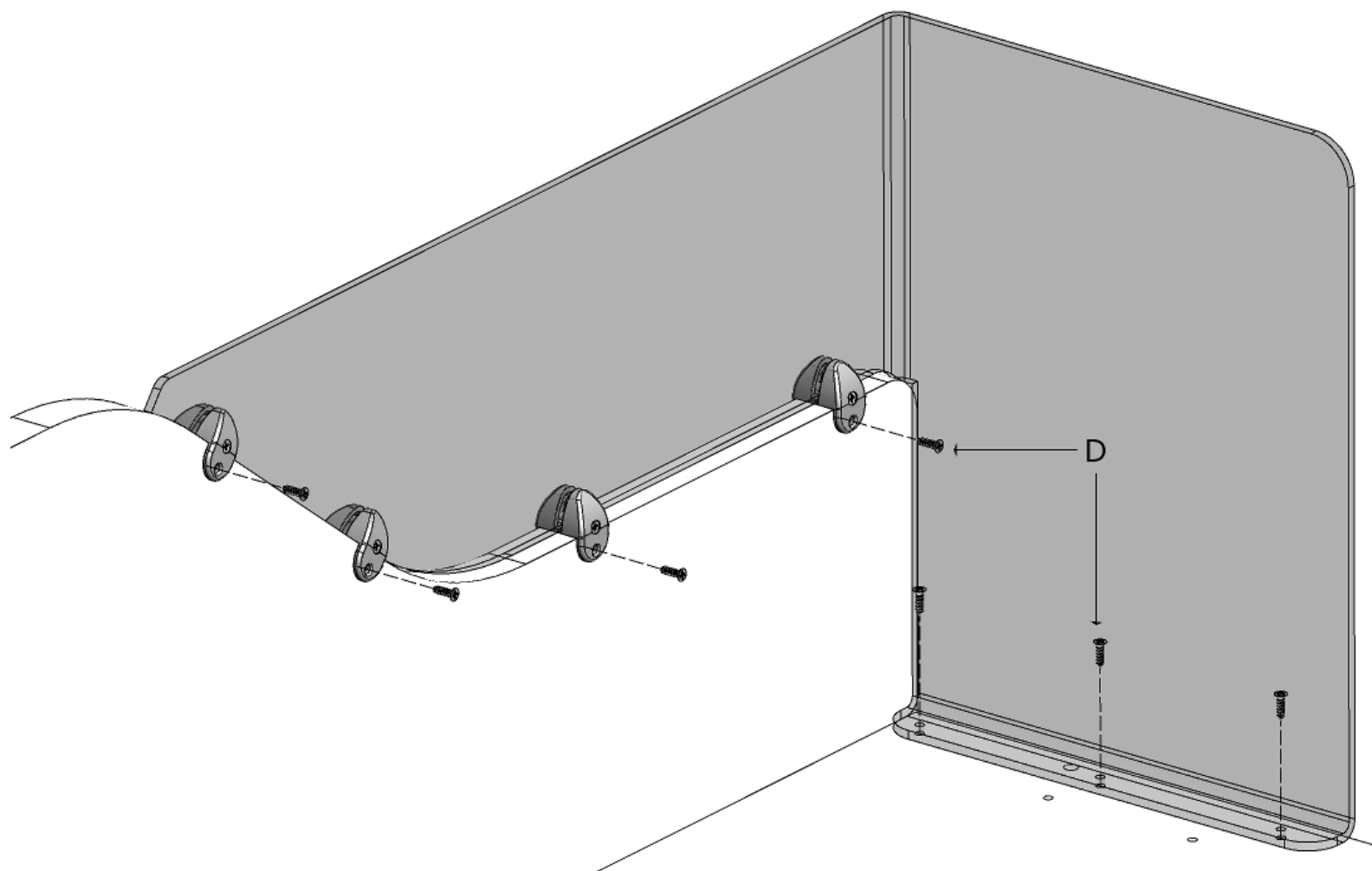
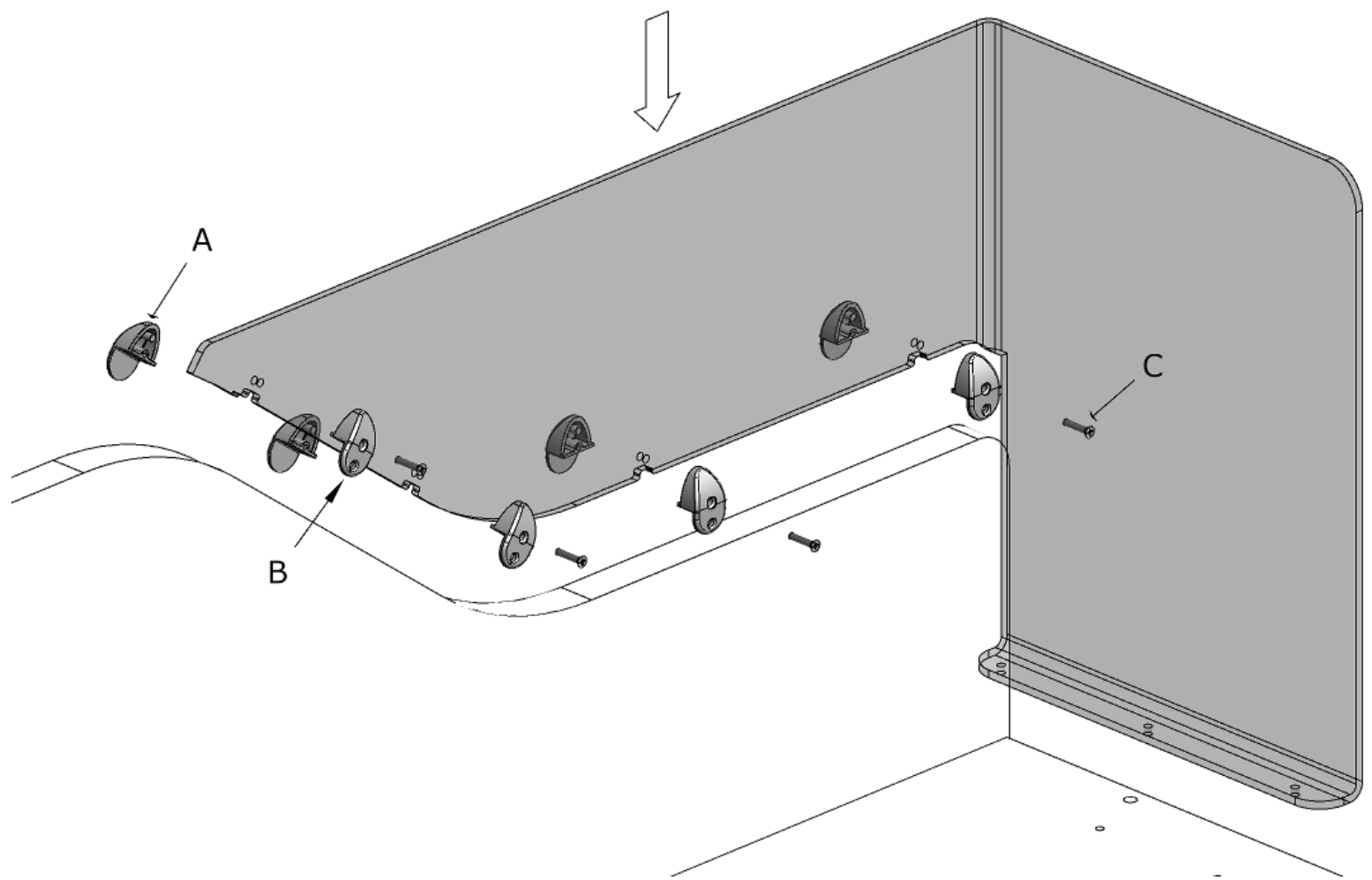

SFR_SAC.FR.FISS PROTEZ. SIDE

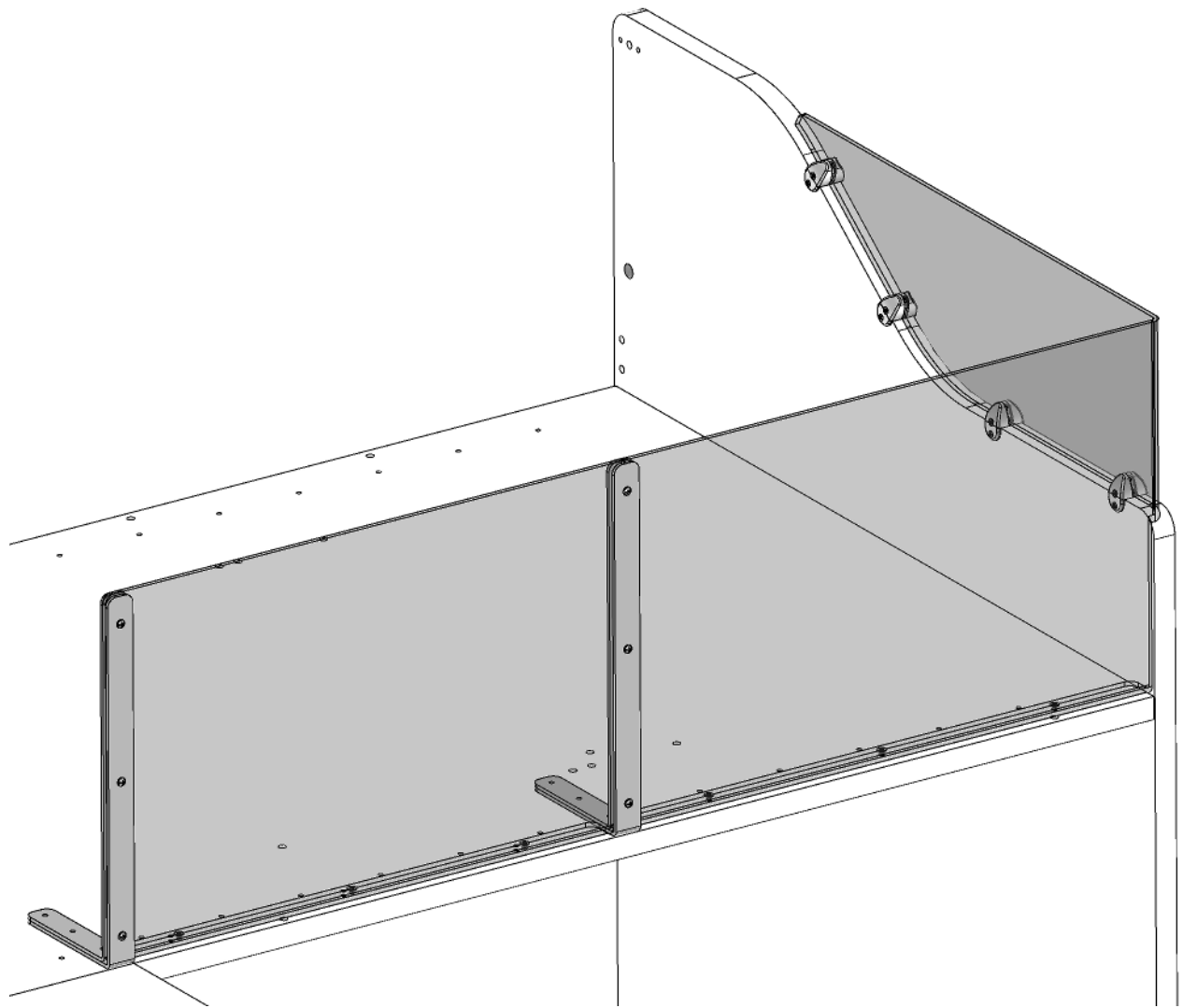
A		n°4	
B		n°4	
C		n°4	
D		n°7	



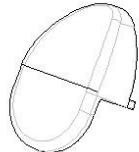
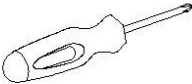
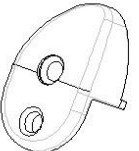

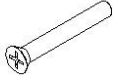

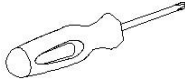

SFR_SAC.FR.FISS PROTEZ. SIDE

	A		n°4	
	B		n°4	
	C		n°4	
	D		n°7	

080005829 - SFR_Sac.Fr.Fiss Prt.Posteriore



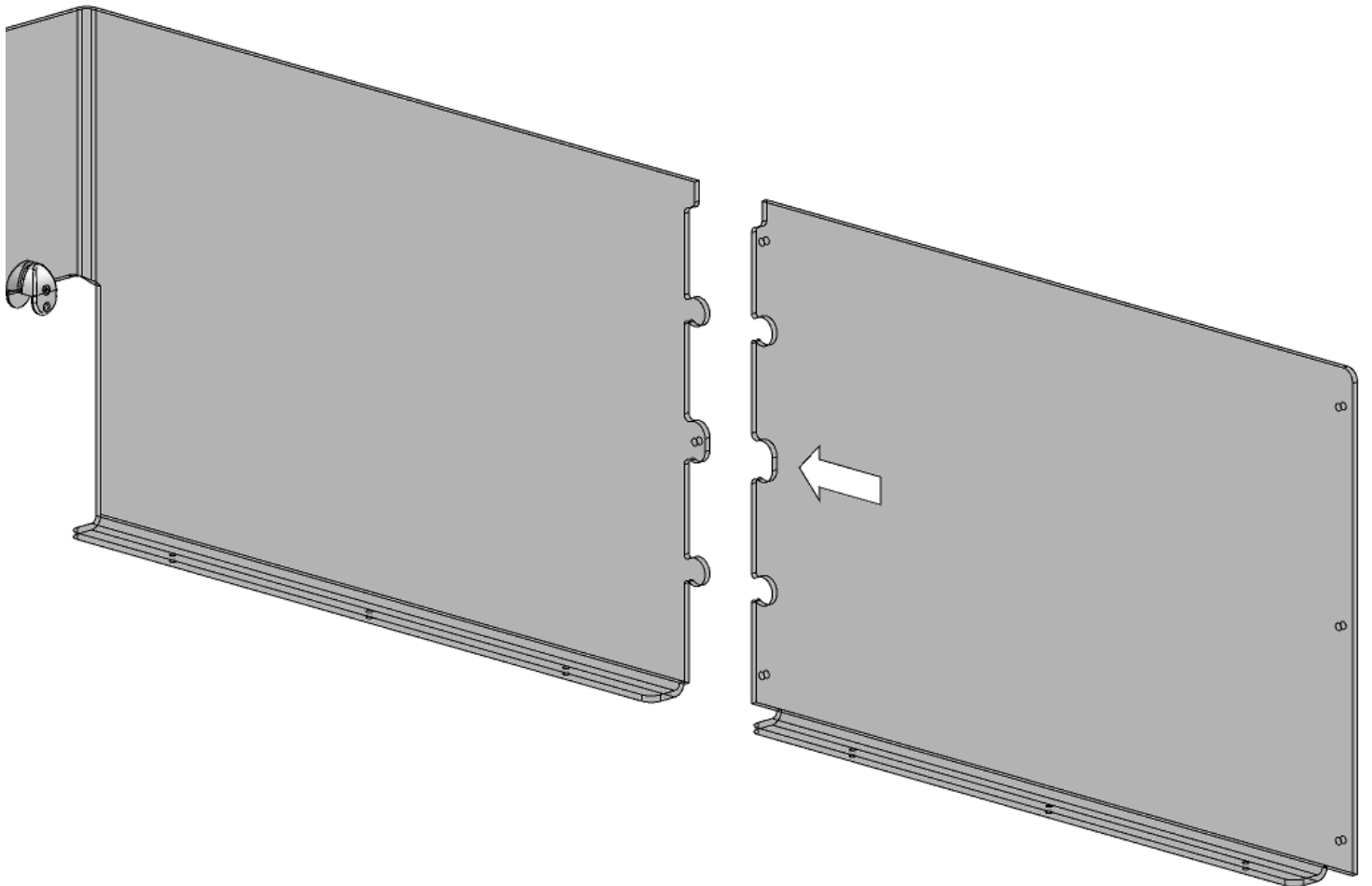
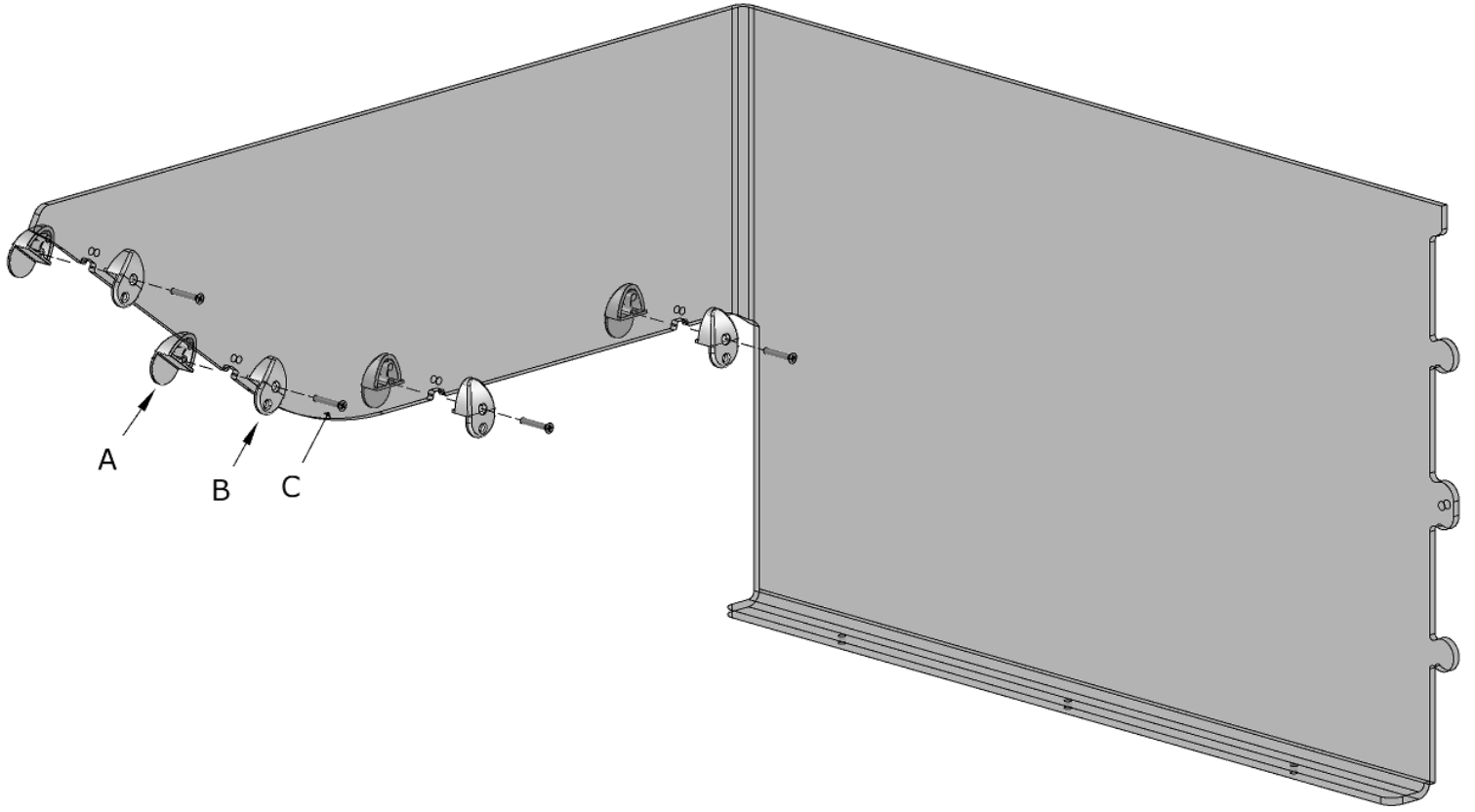

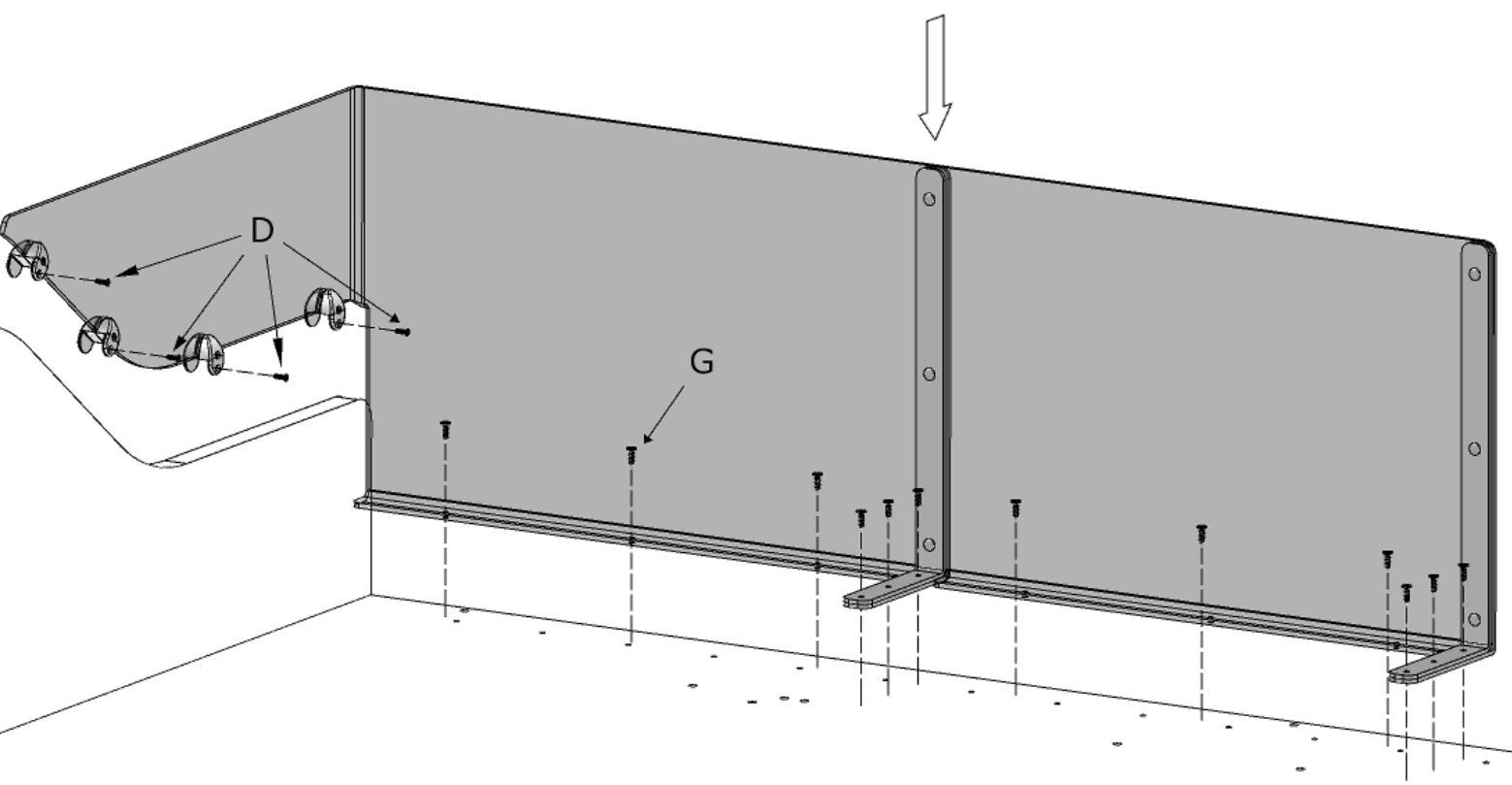
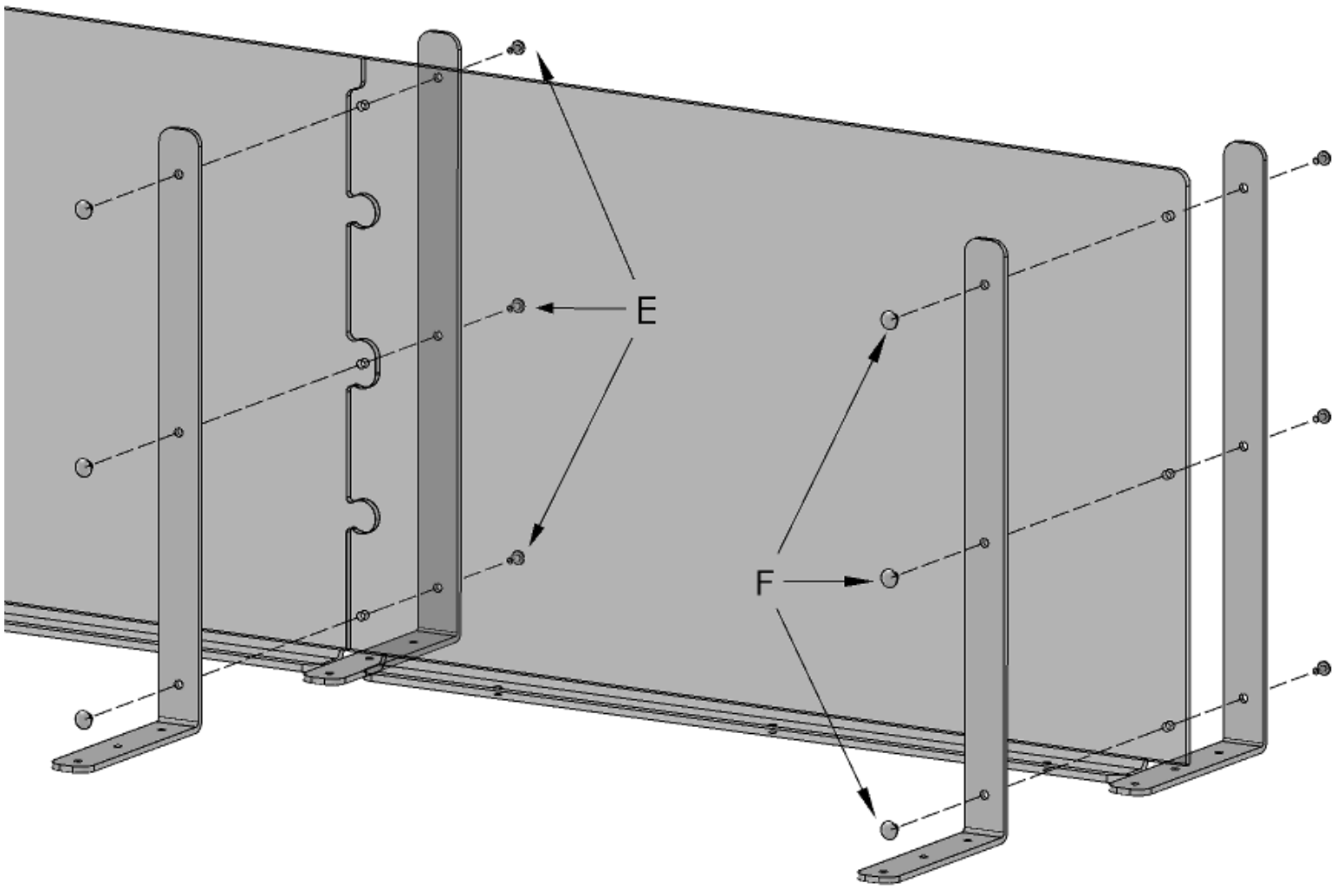
200000920	E		n°6	
200000871	F		n°6	
200002991	G		n°13	

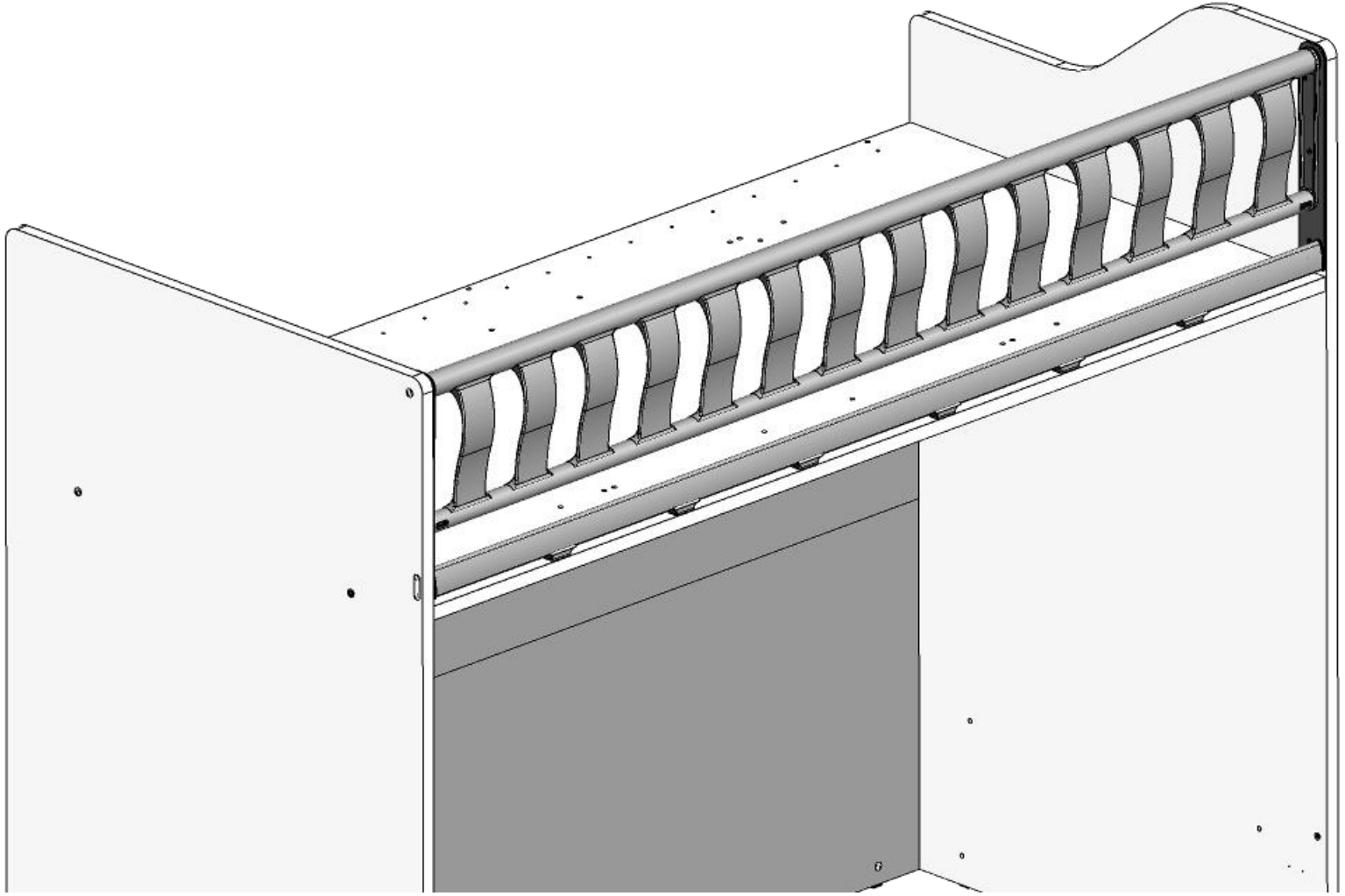



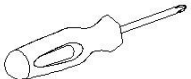

080005827 - SFR_Sac.Fr.Fiss Prot.LongSmall



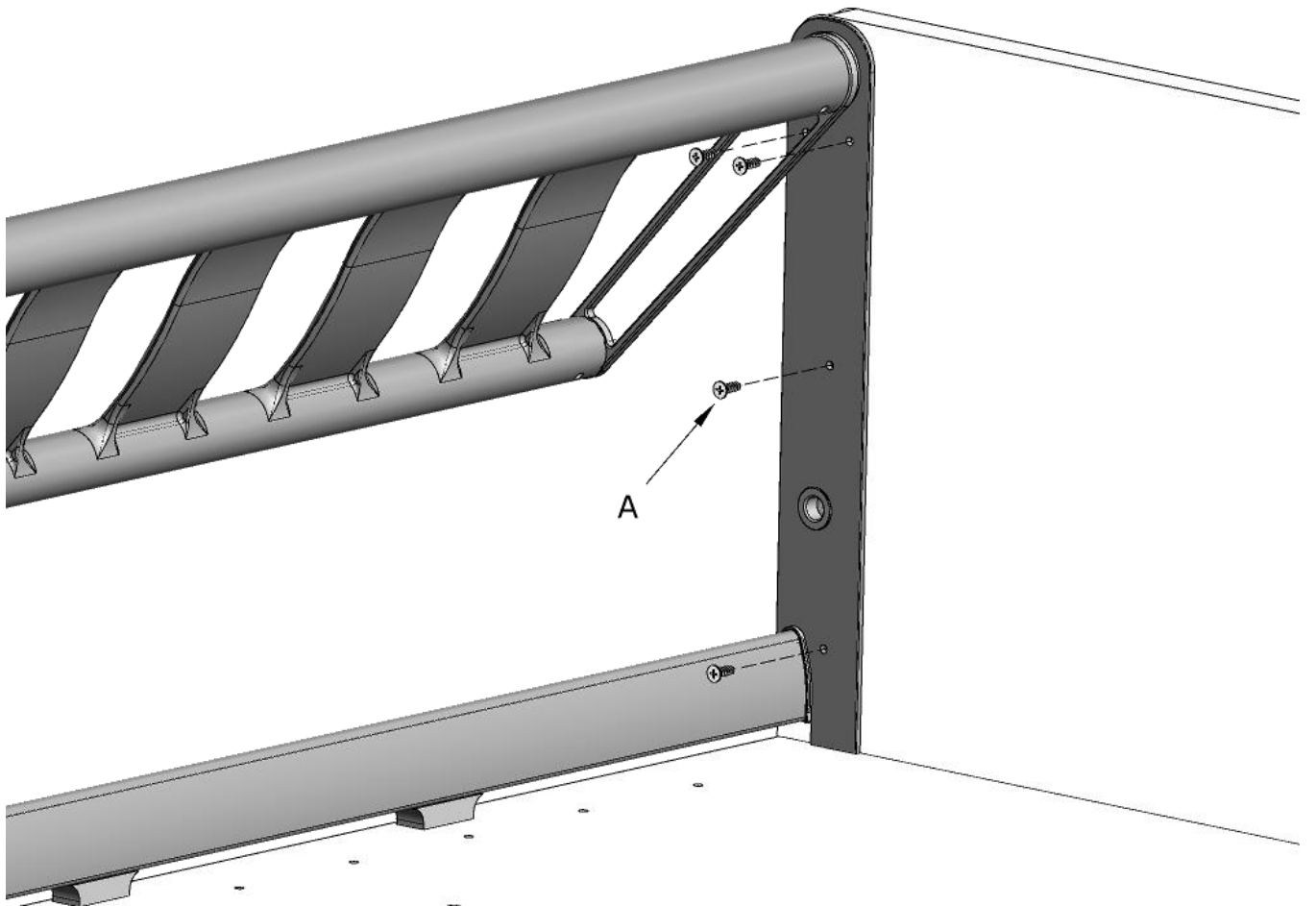
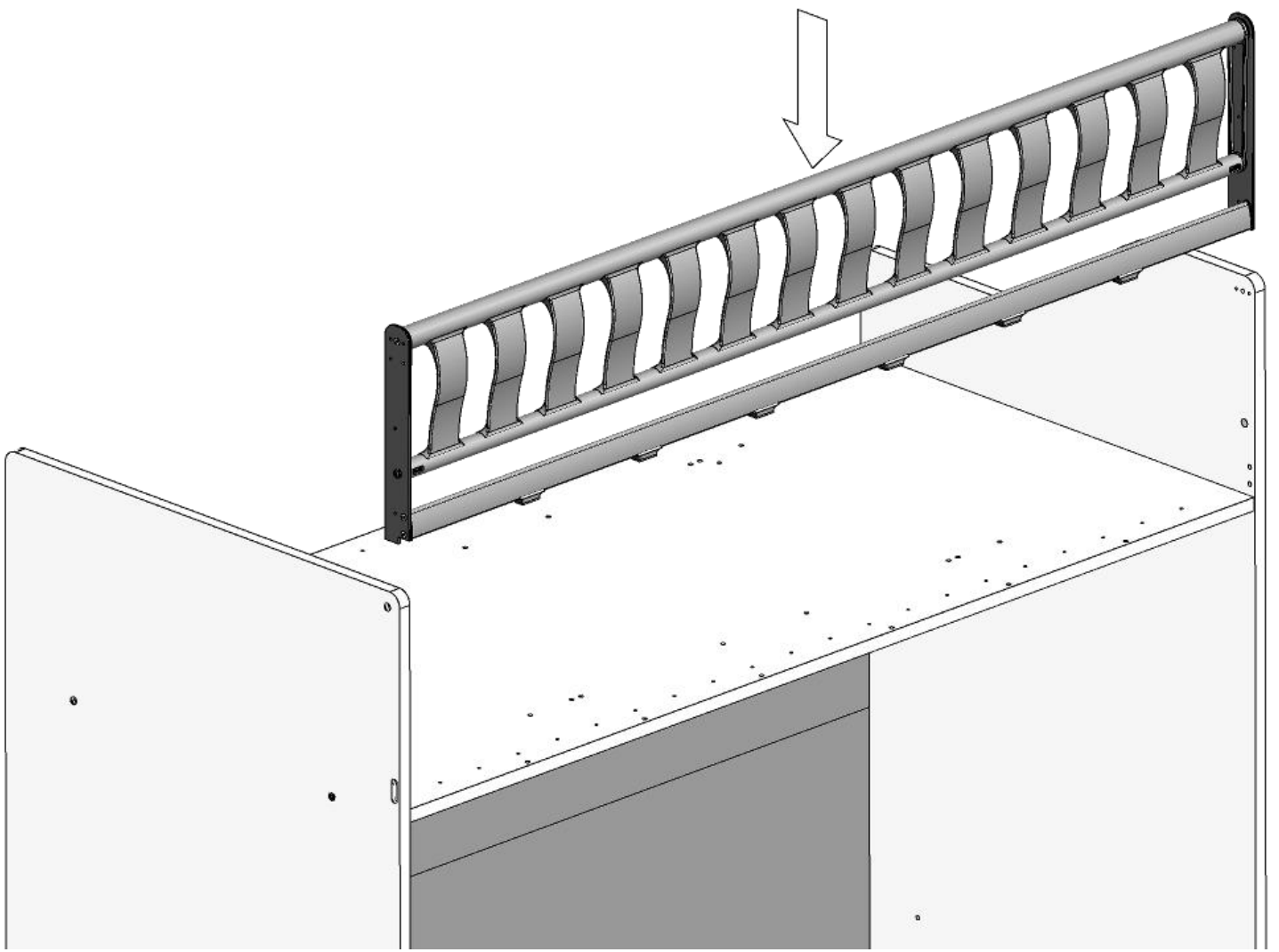

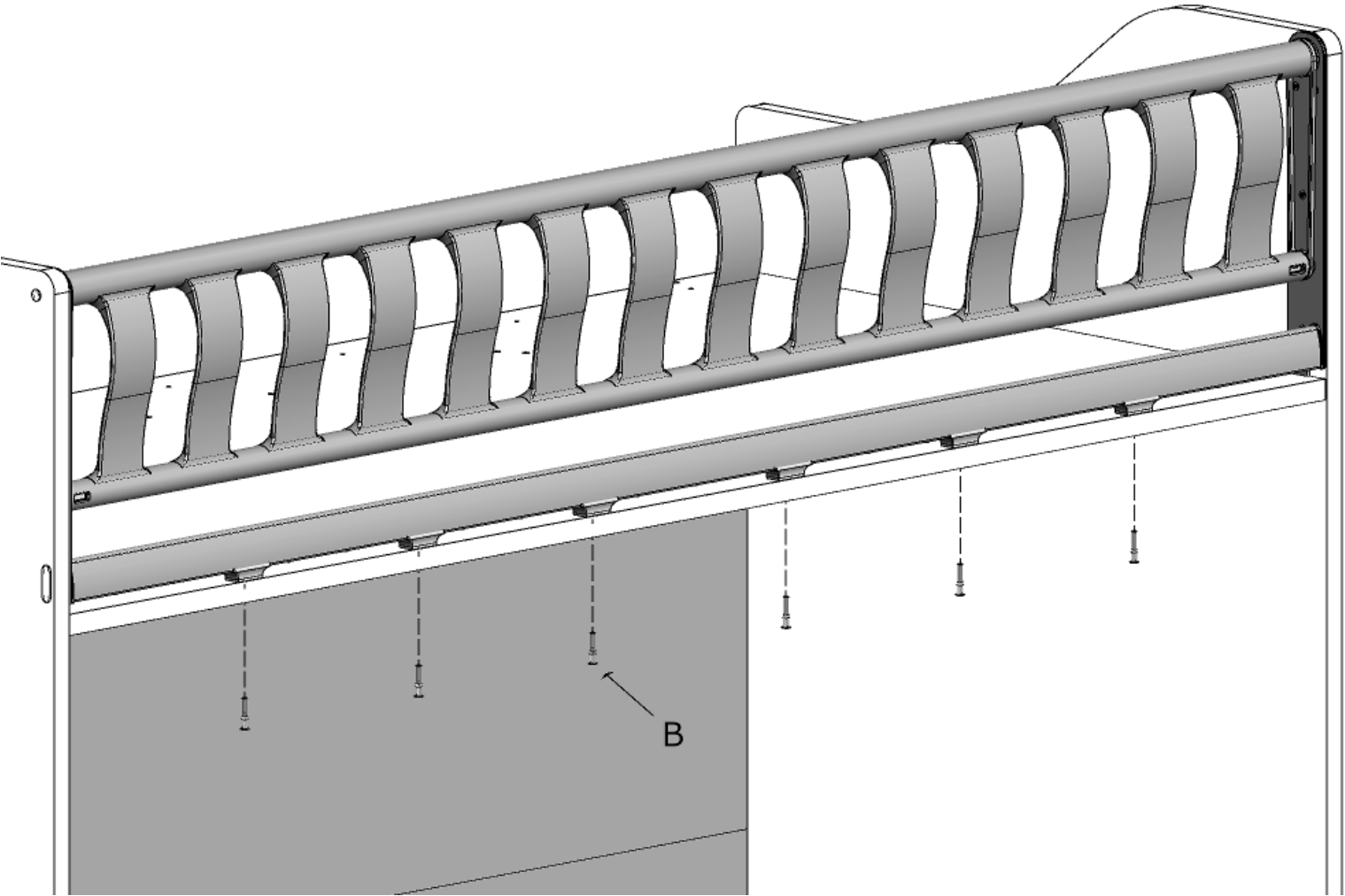
200002990	A		n°8	
200000997	B		n°6	
200002160	C		n°1	

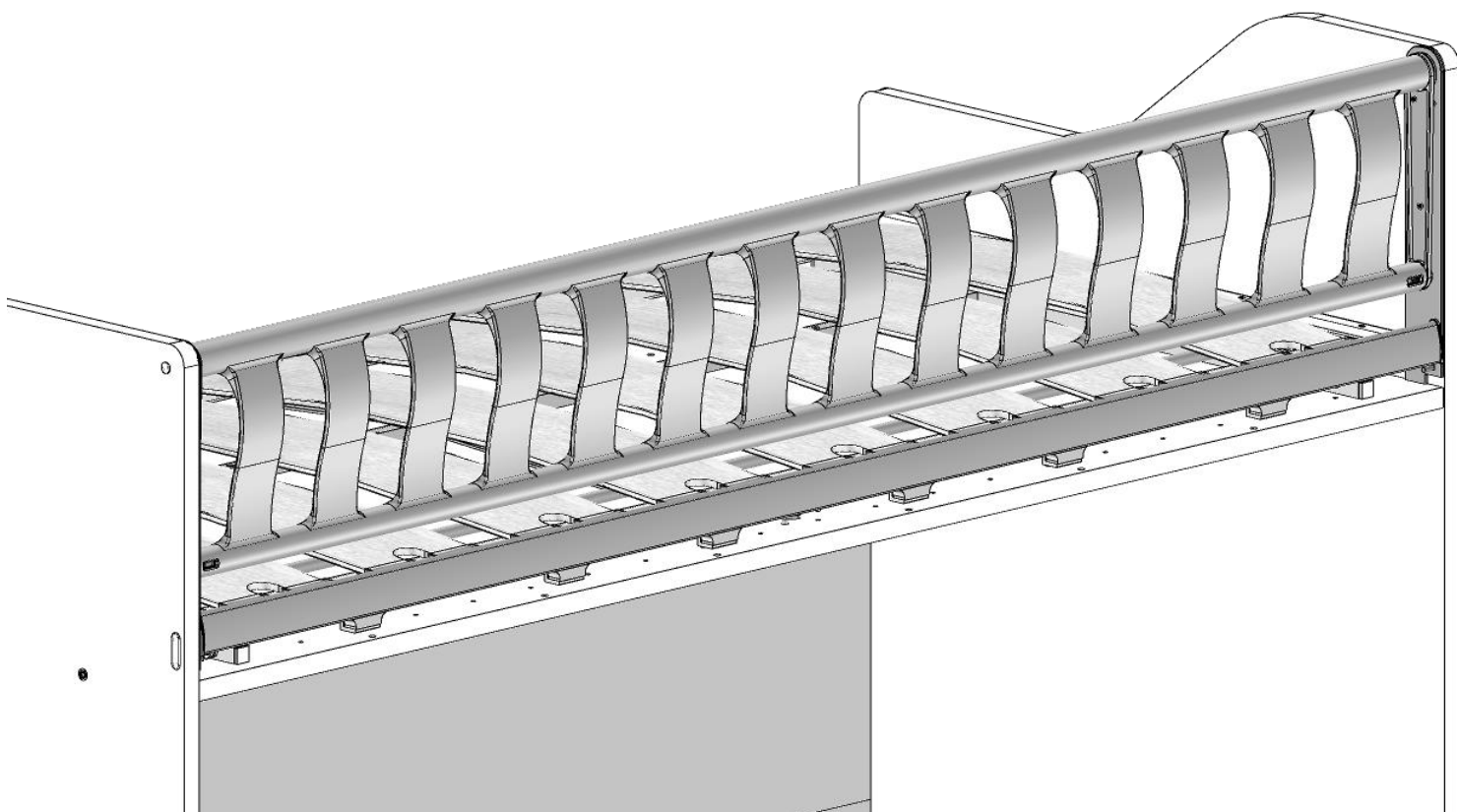



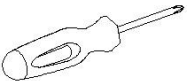

080005826 - SFR_Sac.Fr.Fiss Prot.ReteFlow

200002990	A		n°8	
200000978	B		n°6	
200002160	C		n°2	

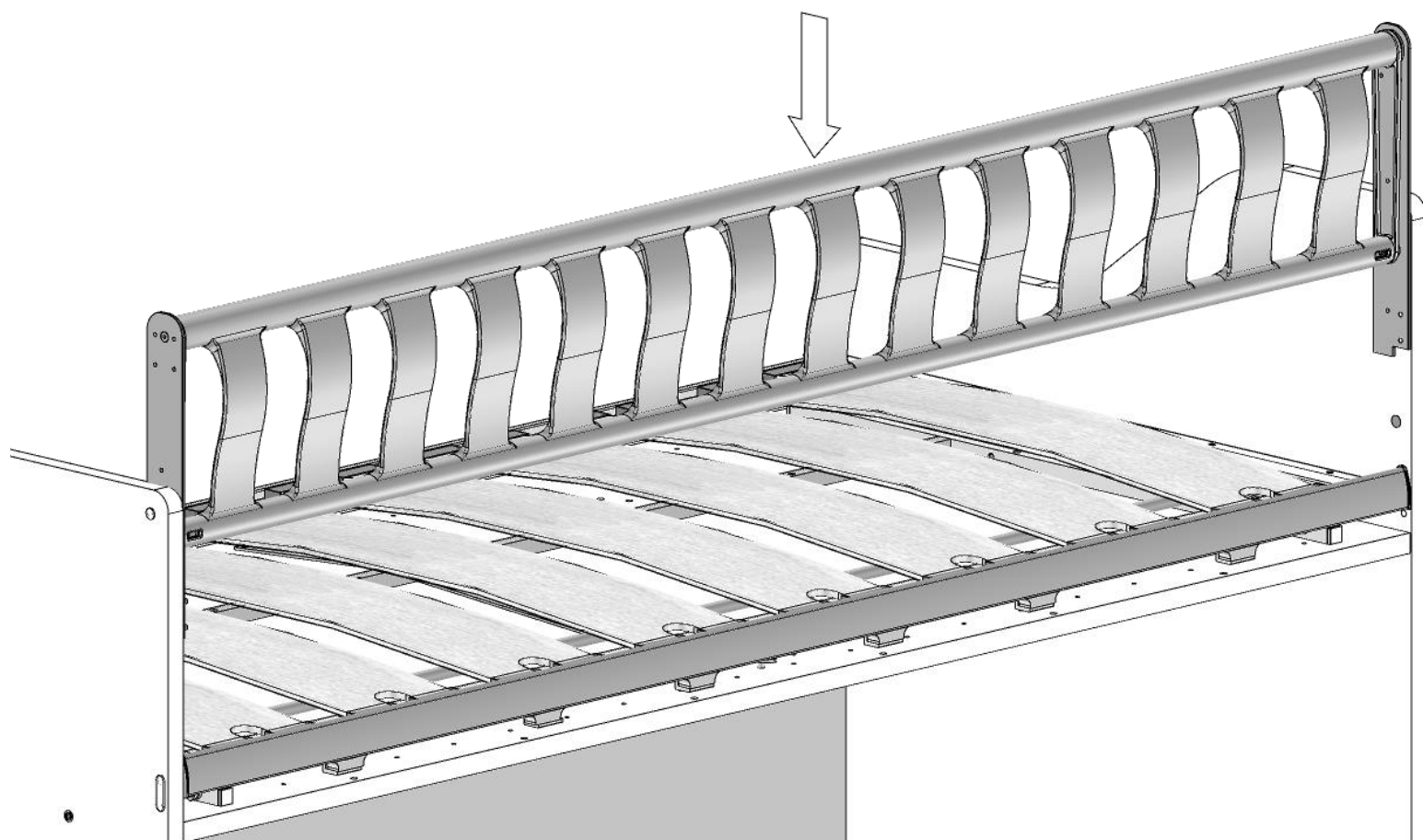
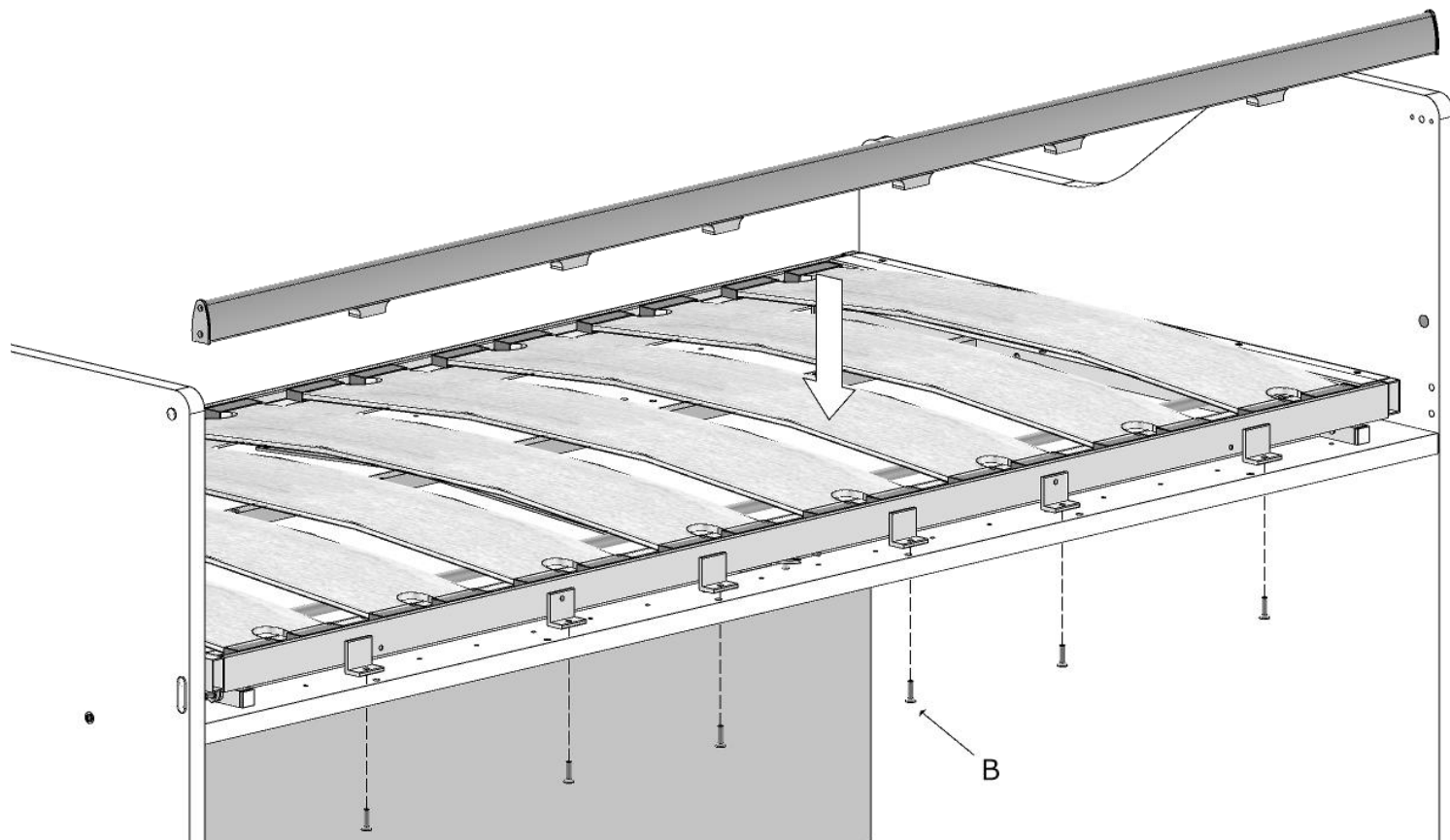

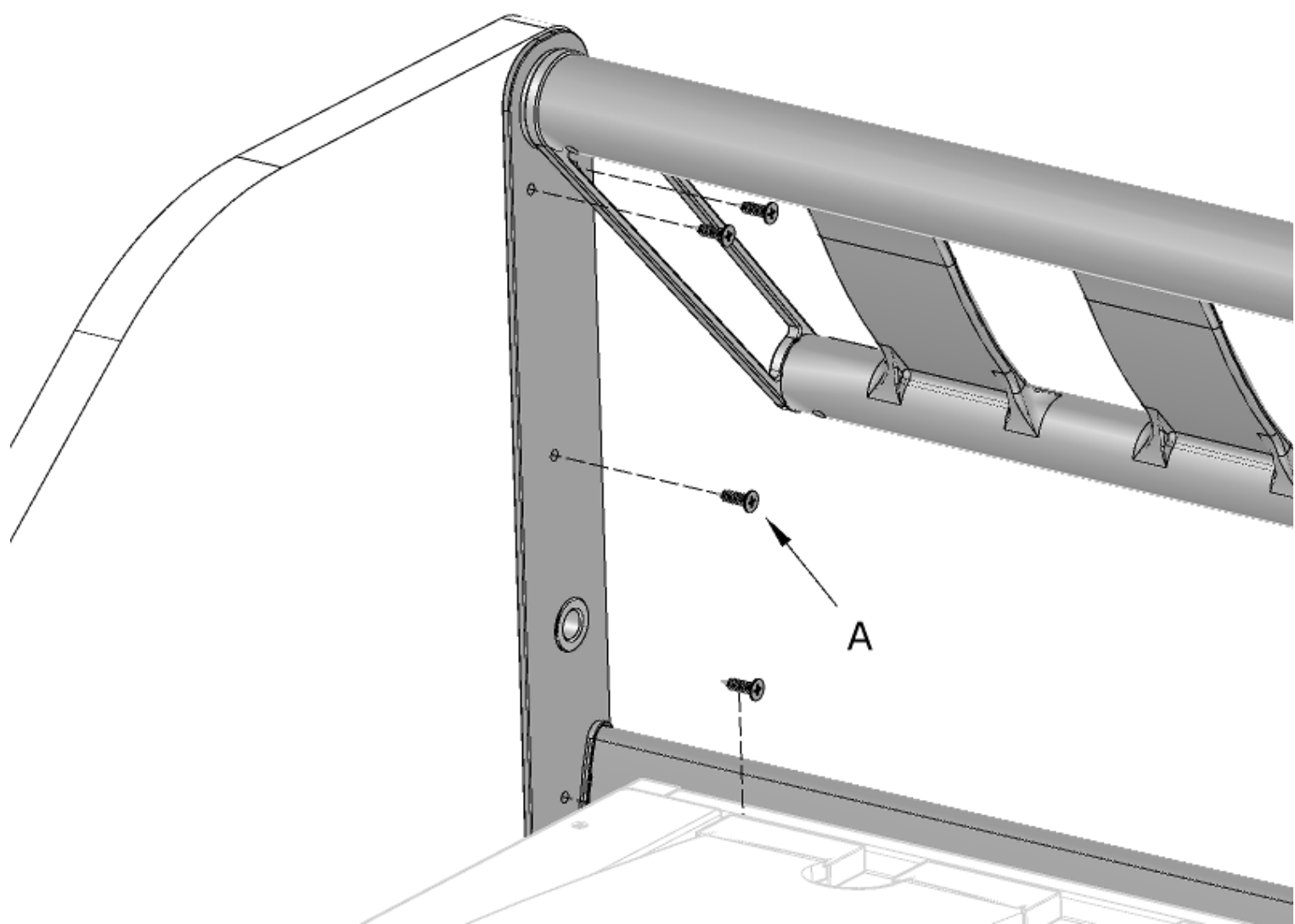

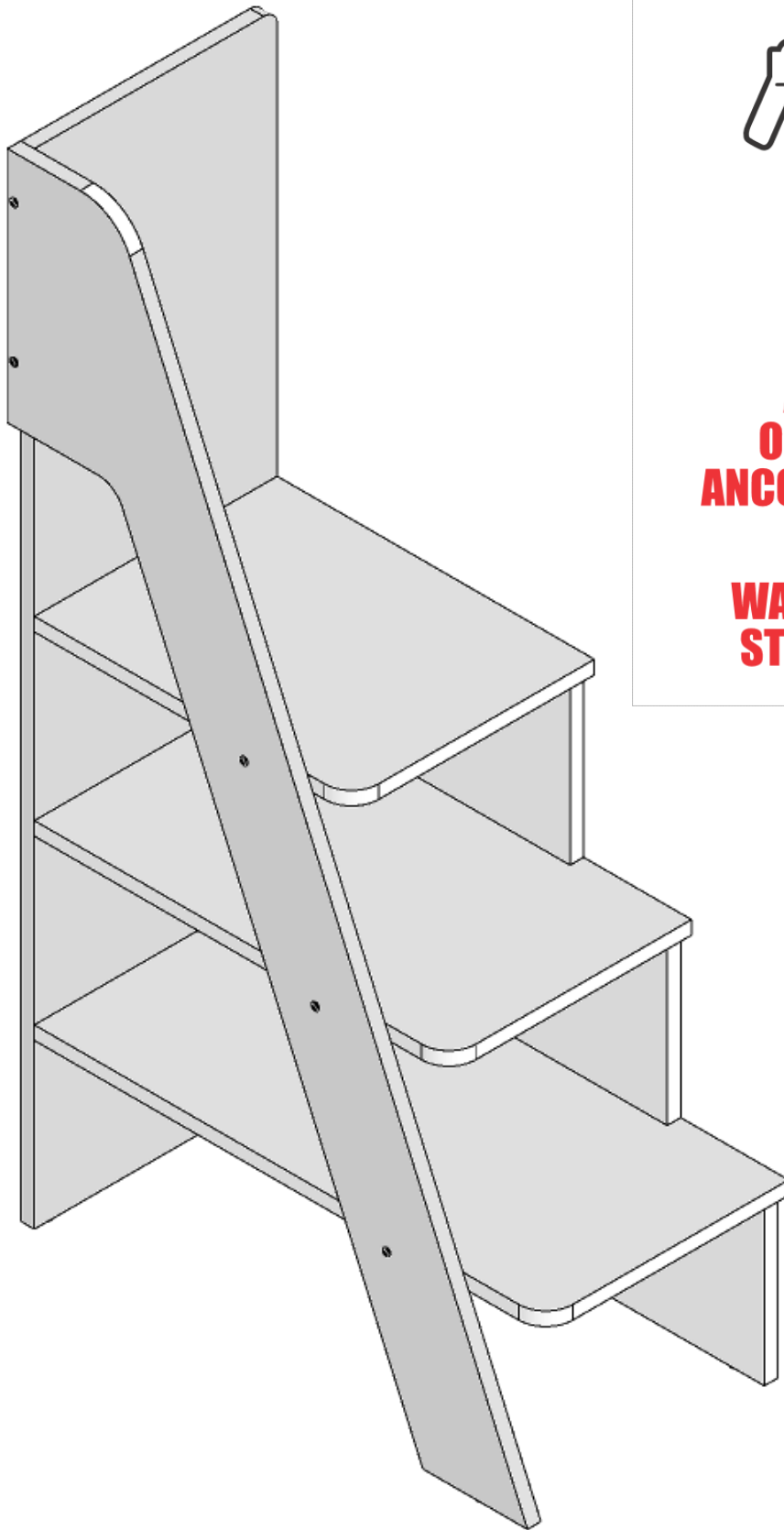



**ATTENZIONE!
OBBLIGATORIO
ANCORAGGIO A MURO**

**WARNING!
WALL ANCHORING
STRICTLY NEEDED**

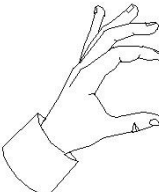
080005831 - SFR_Sac.Fr.Scl.LatEVO 3Gradini

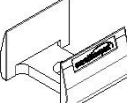
200000666	A		n°10	
200000996	B		n°11	
200002977	C		n°3	

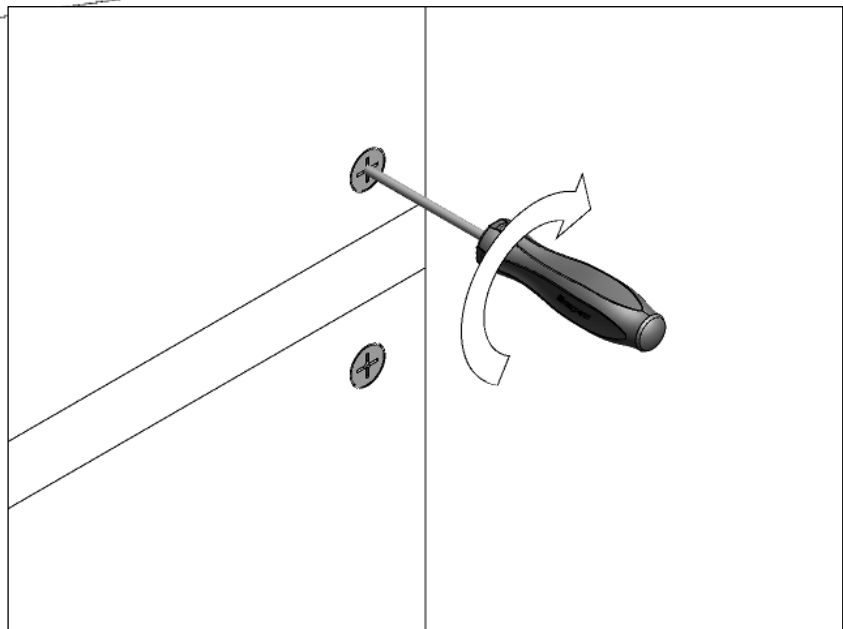
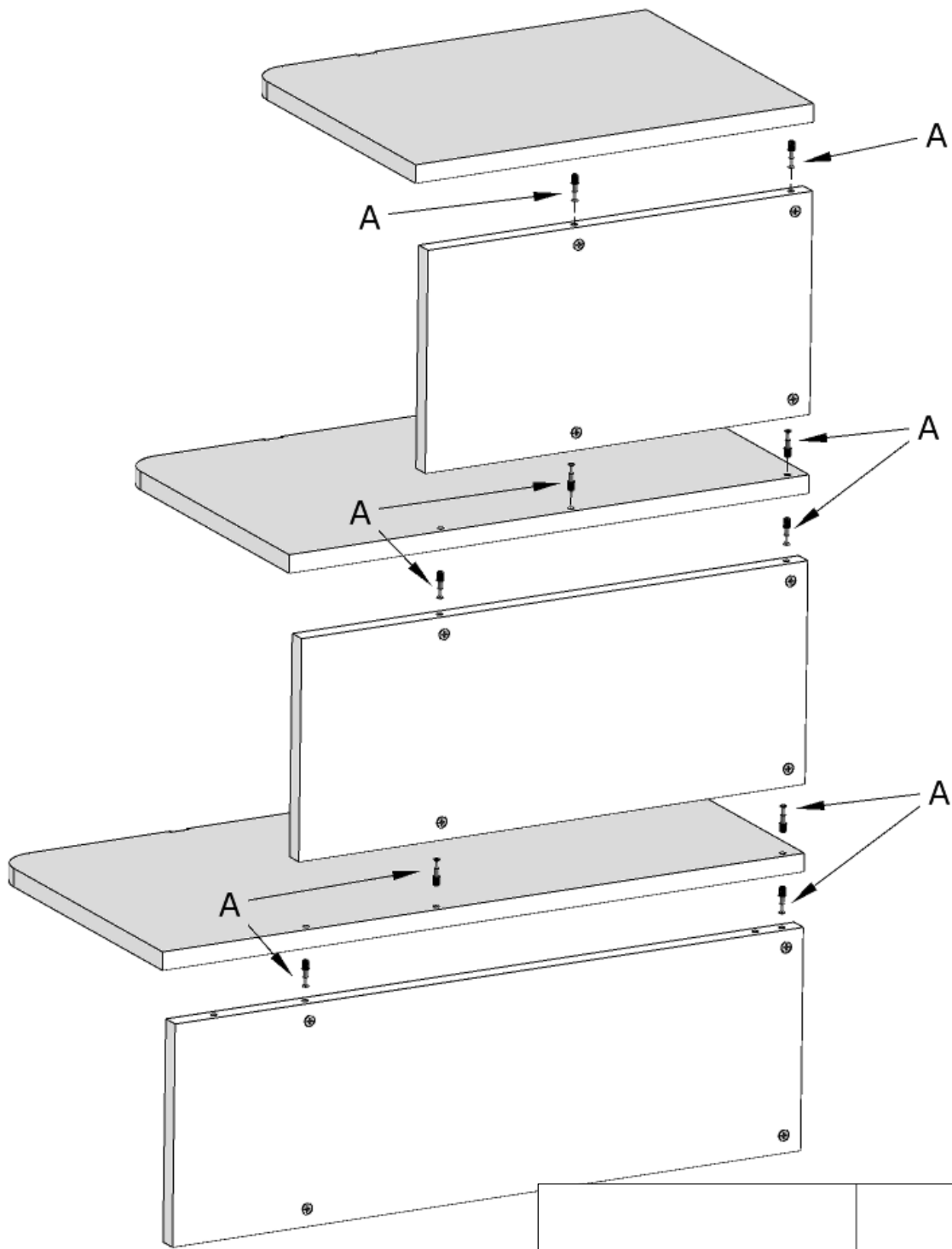

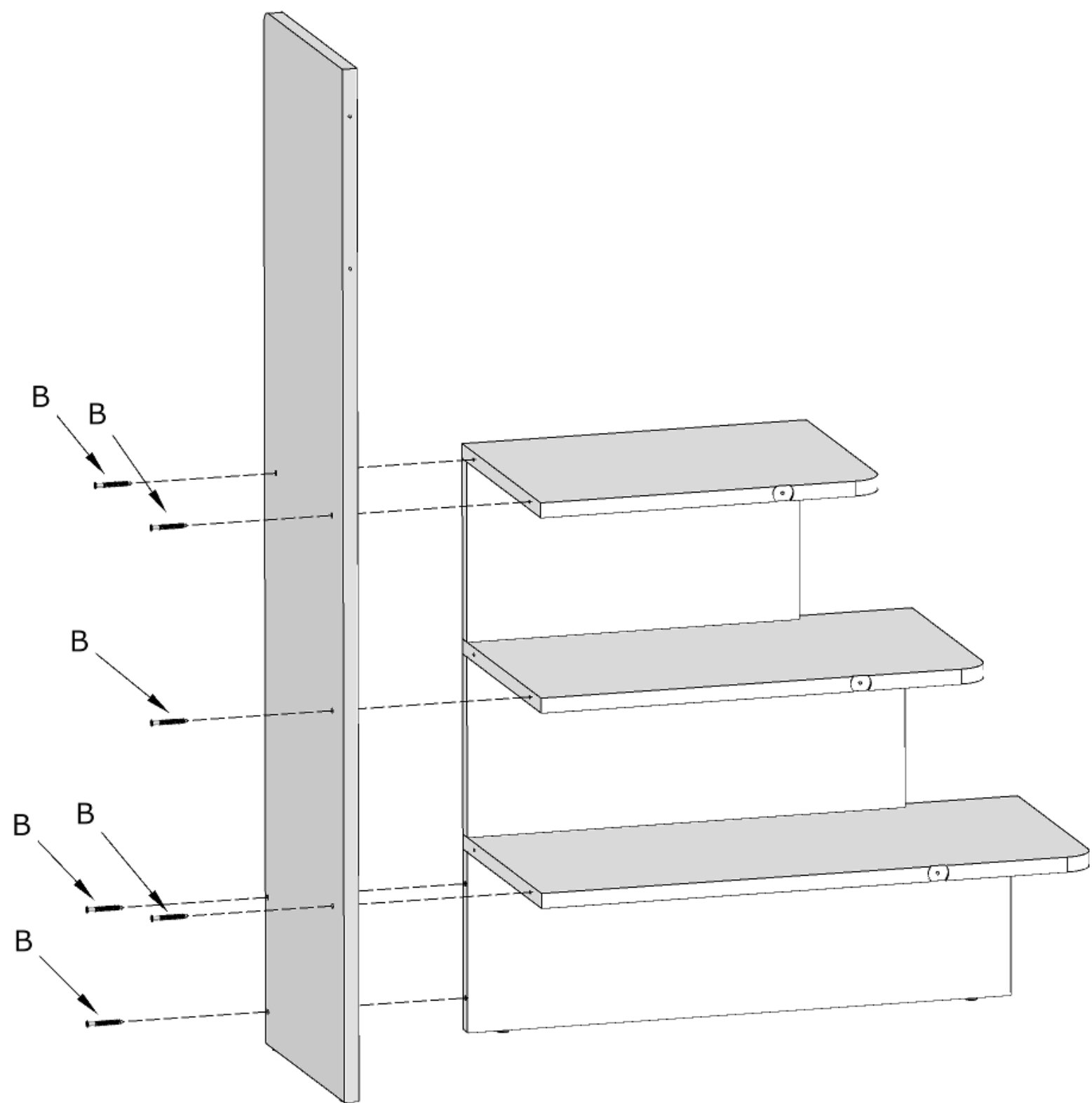

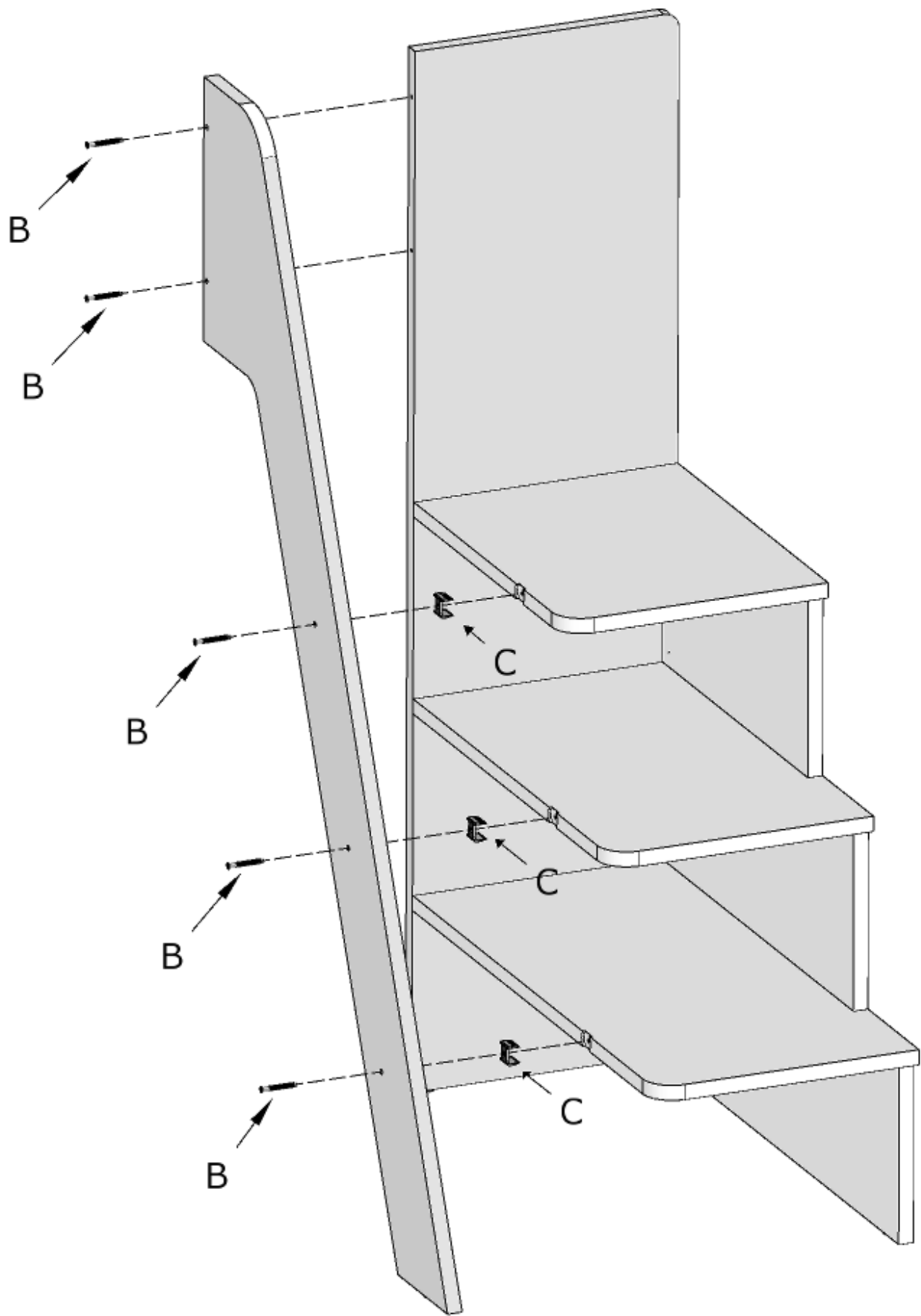

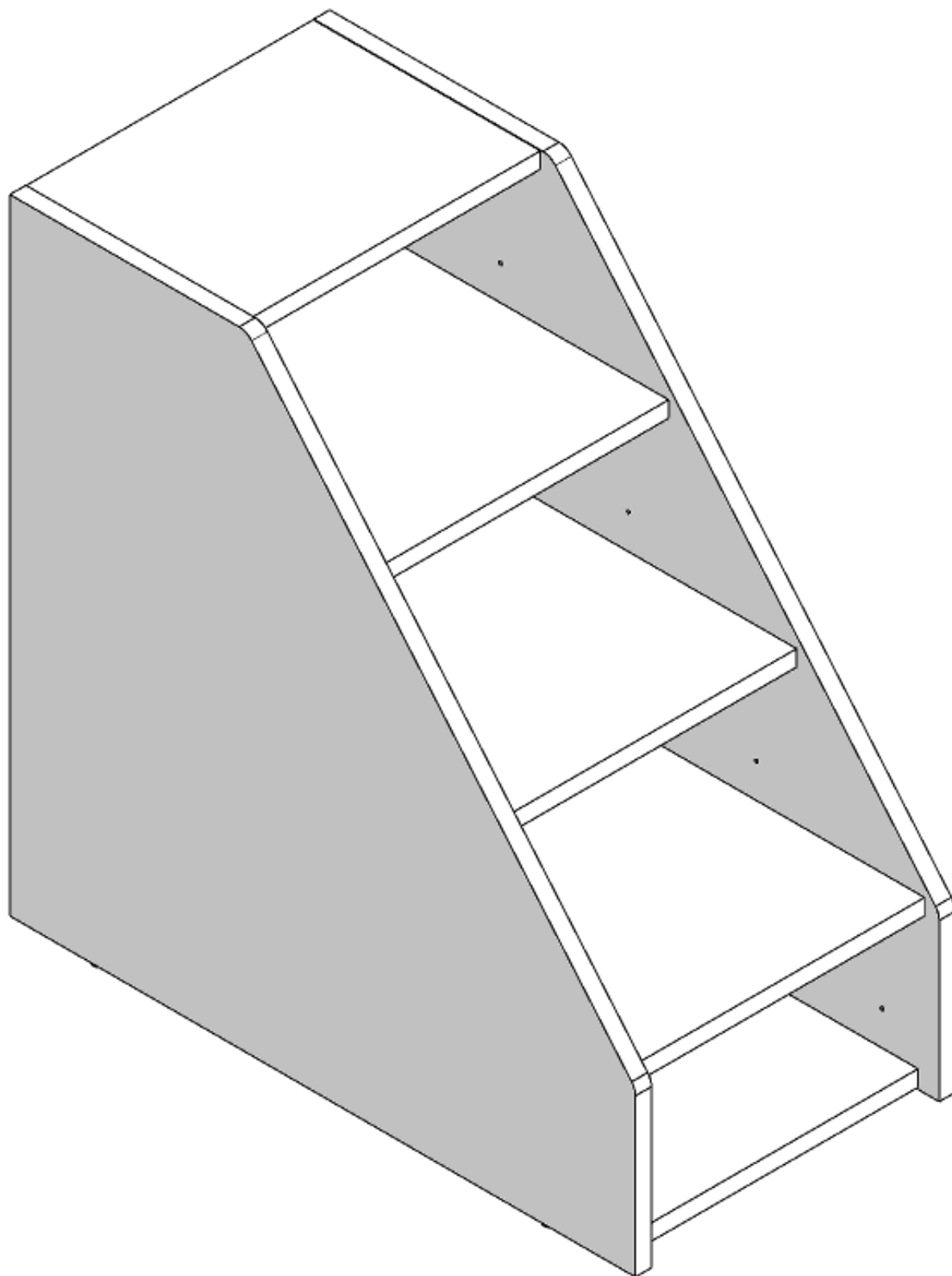

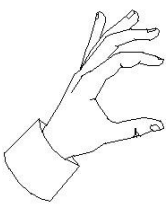

080005111 - SFR_Sac.Fr.Component.1°Scalino

200000666	A		n°20	
200000653	B		n°36	
200000942	C		n°10	

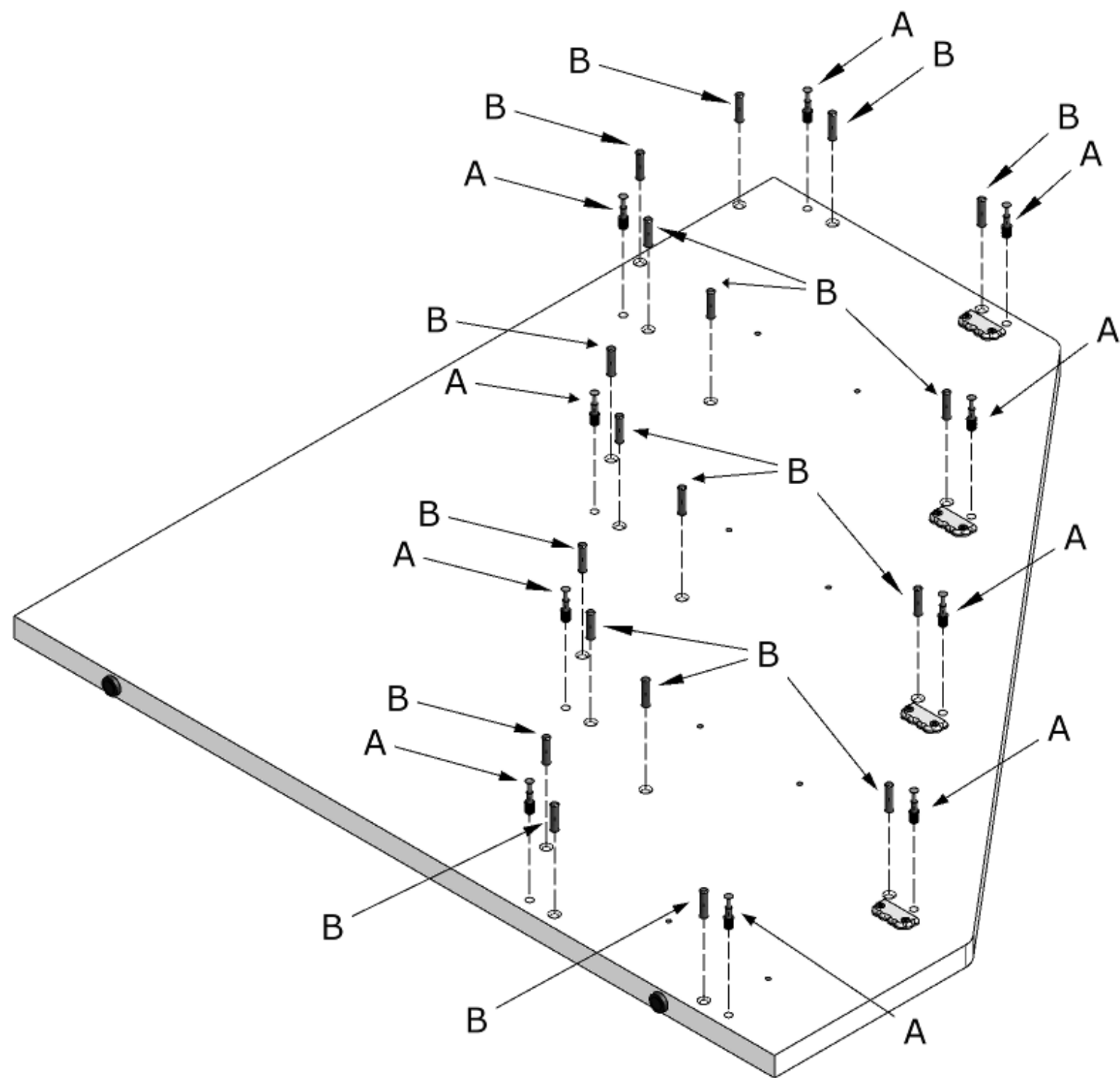

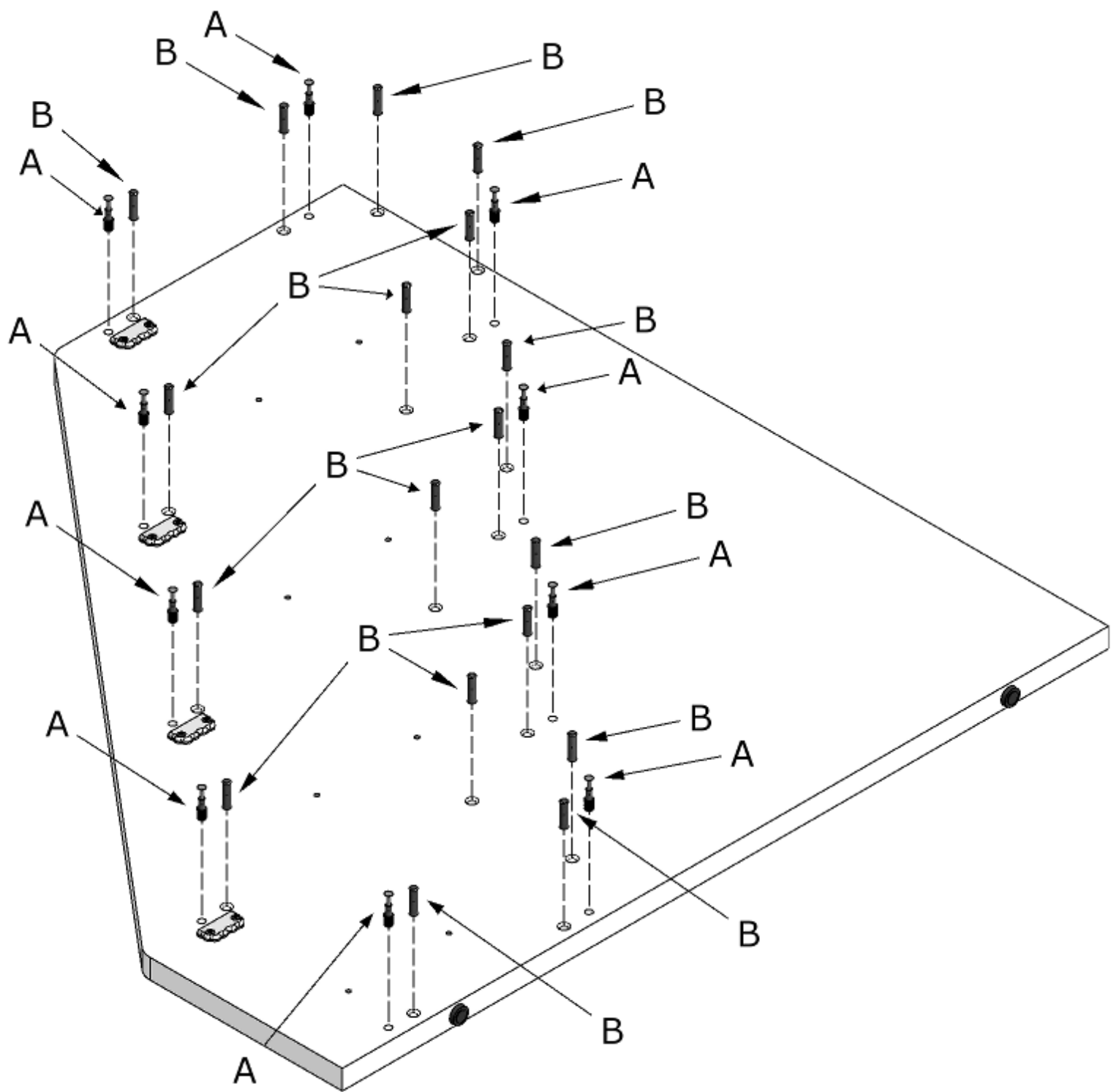

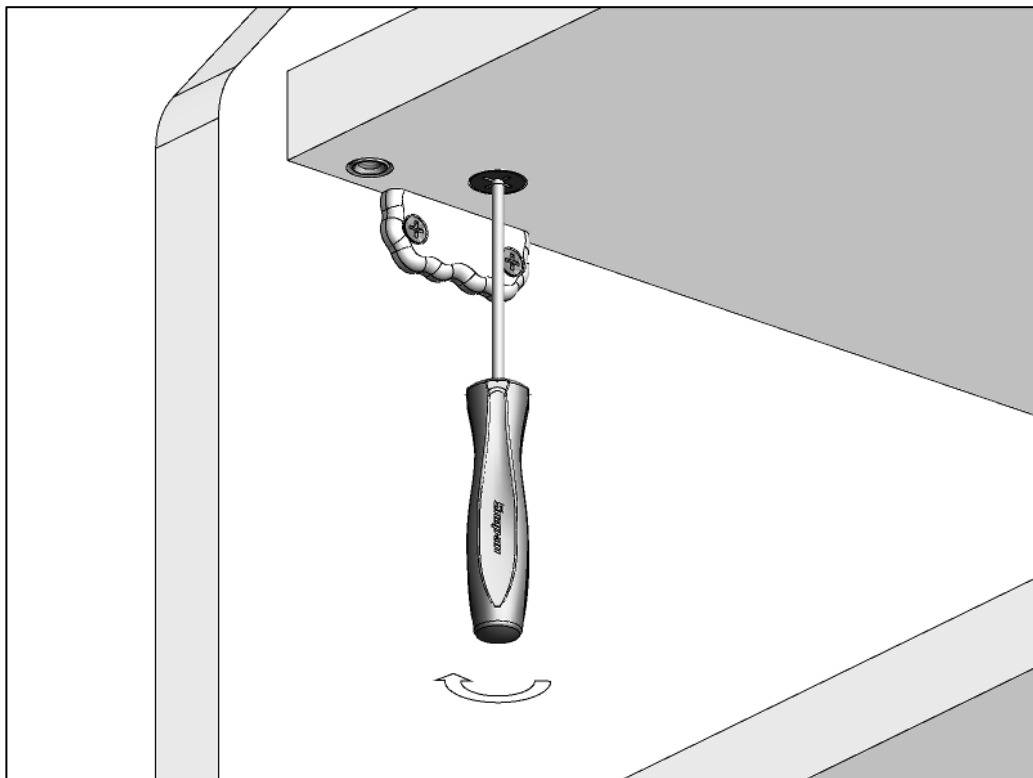
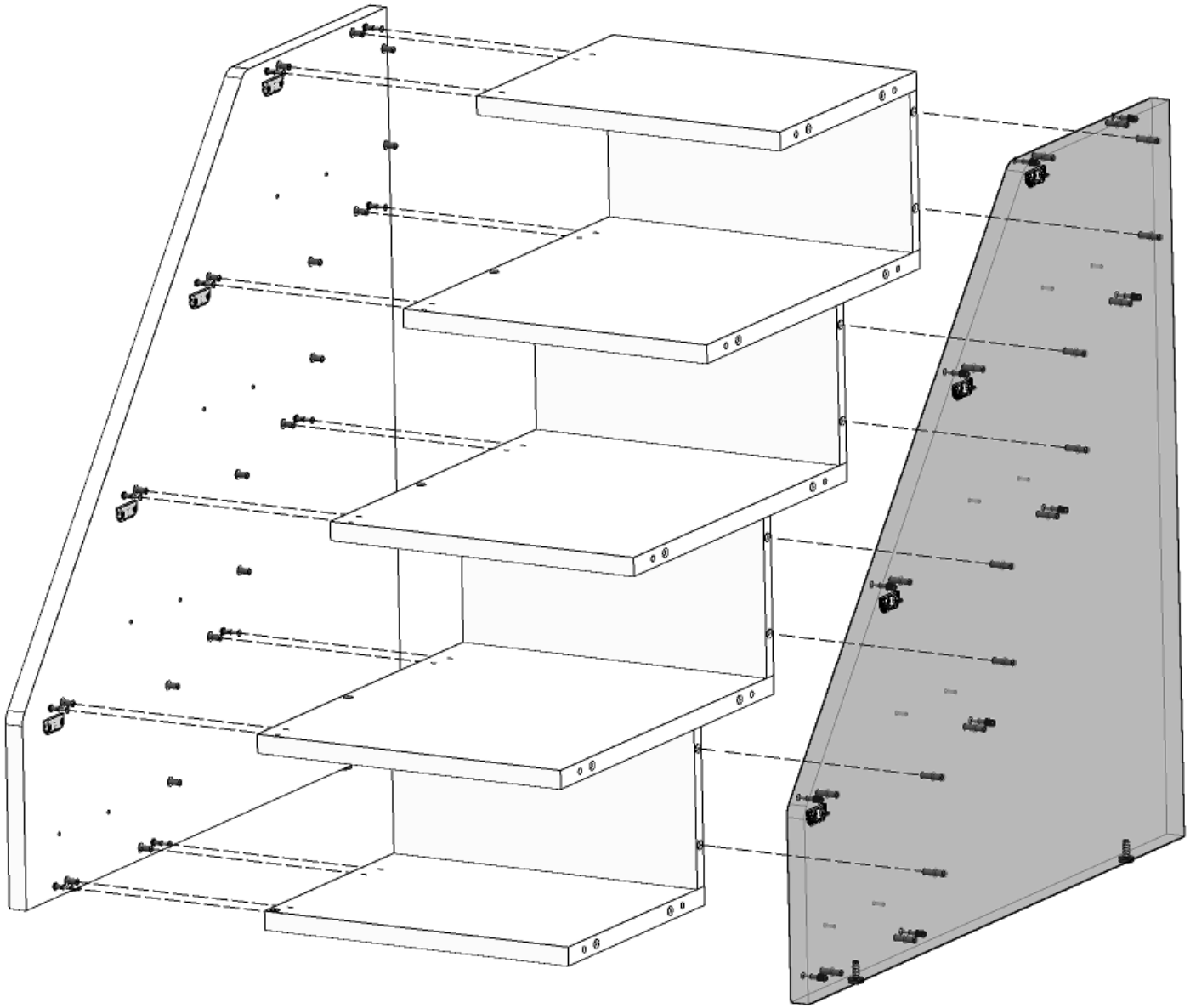

VERSIONE CON CASSETTI

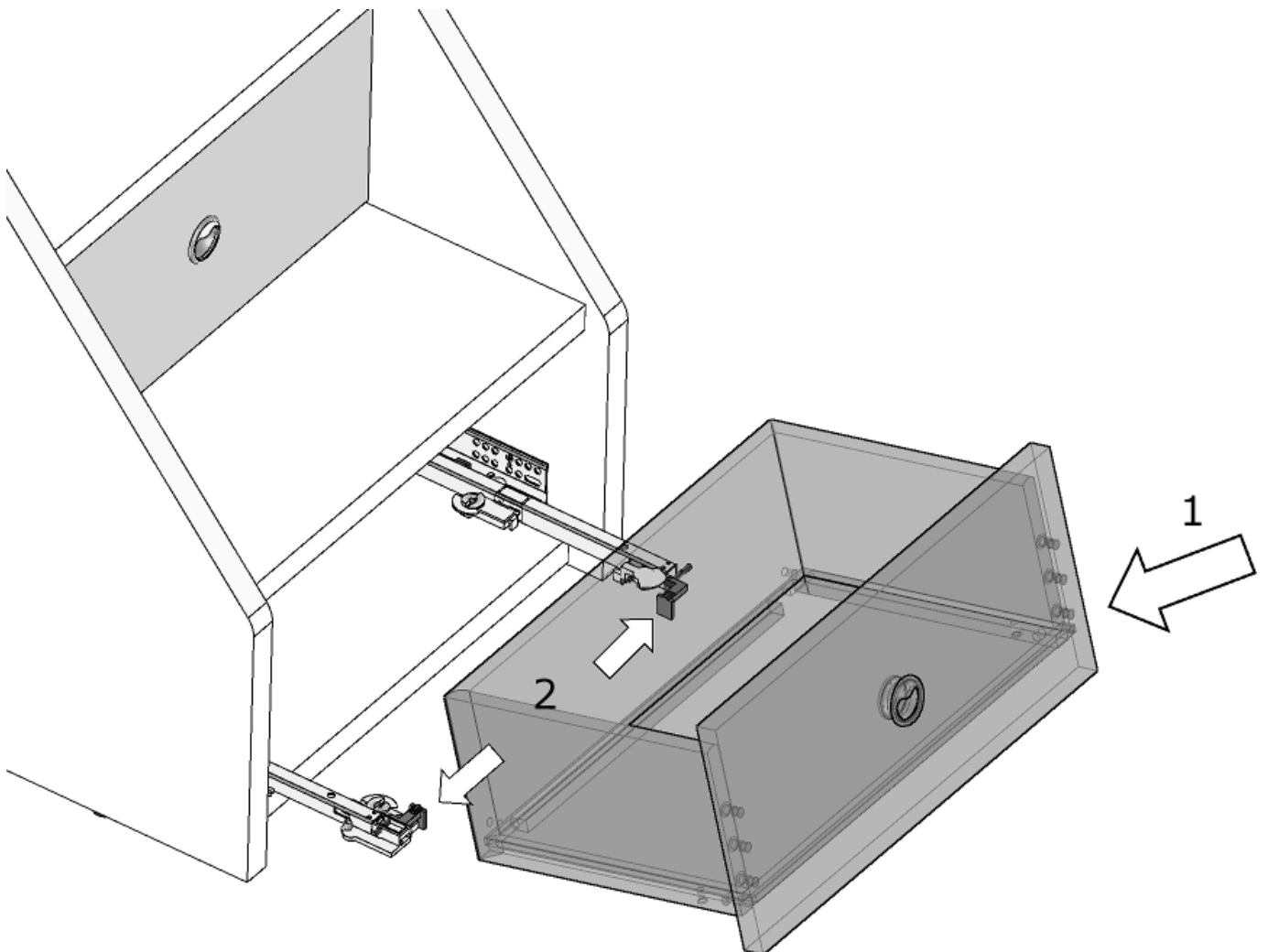
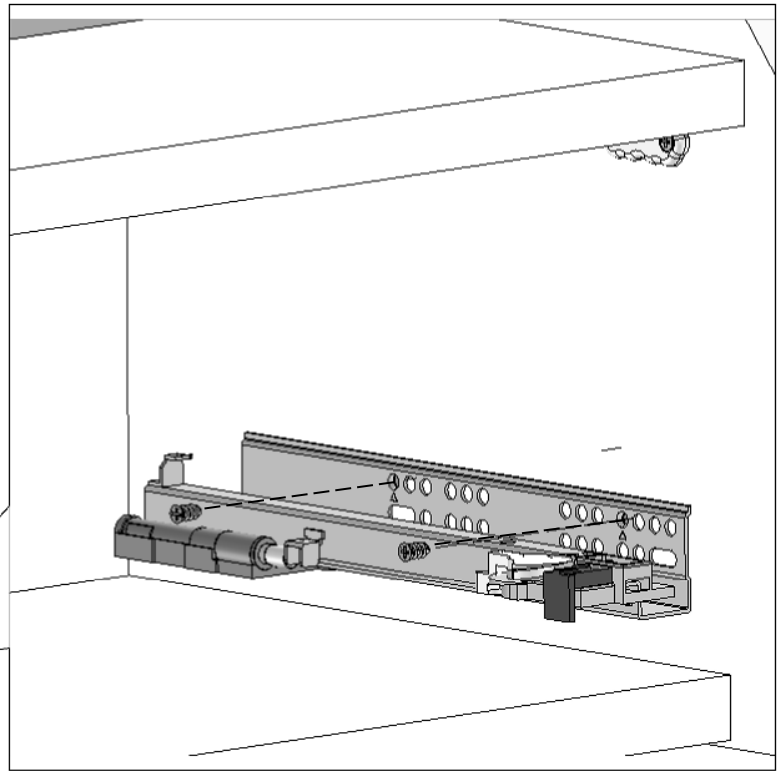
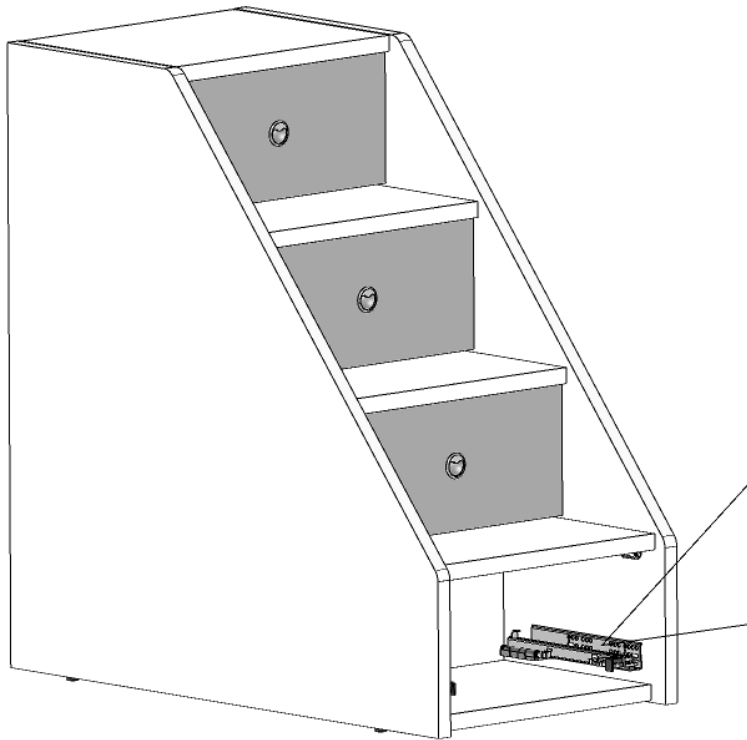

Ruotare la rotella nera verso il frontale del cassetto per aumentare l'aria tra il frontale e il fianco.

Questa operazione si effettua senza l'utilizzo di alcun utensile.

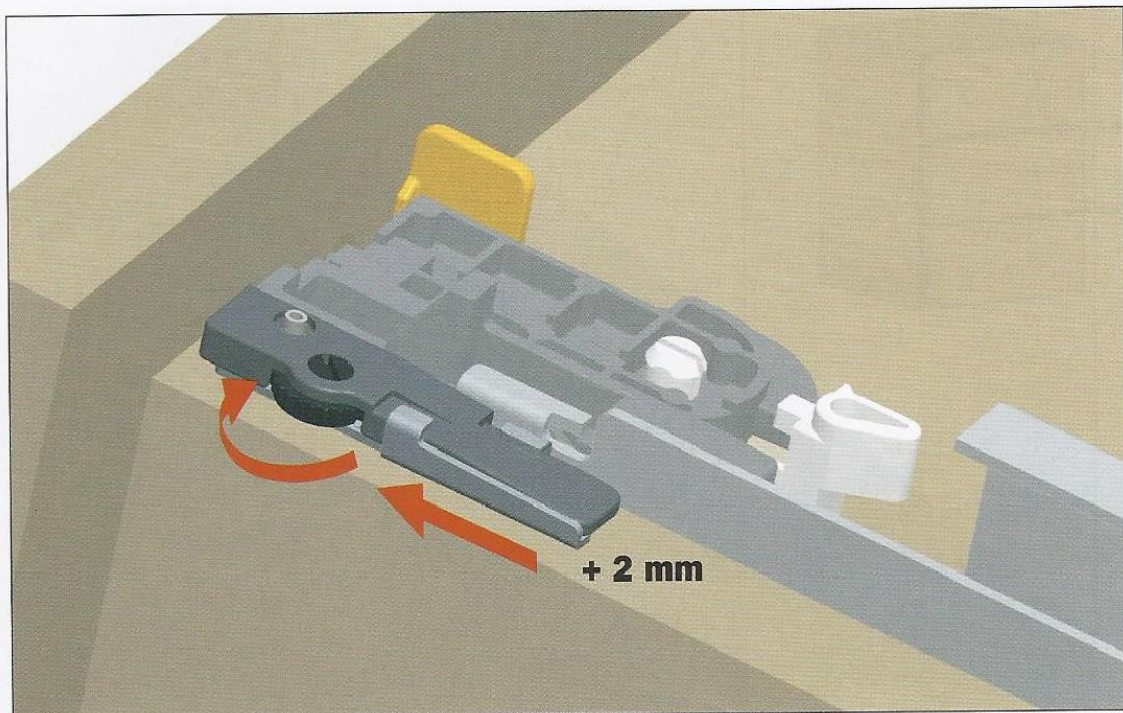
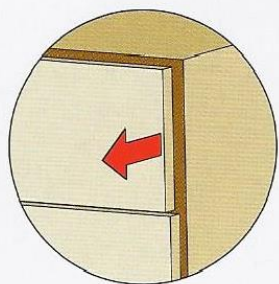
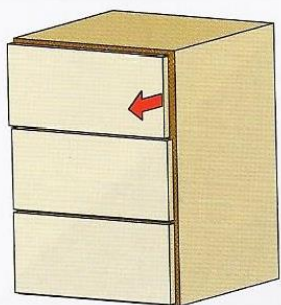

Ruotare la rotella nera verso il retro del cassetto per diminuire l'aria tra il frontale e il fianco.

Questa operazione si effettua senza l'utilizzo di alcun utensile.

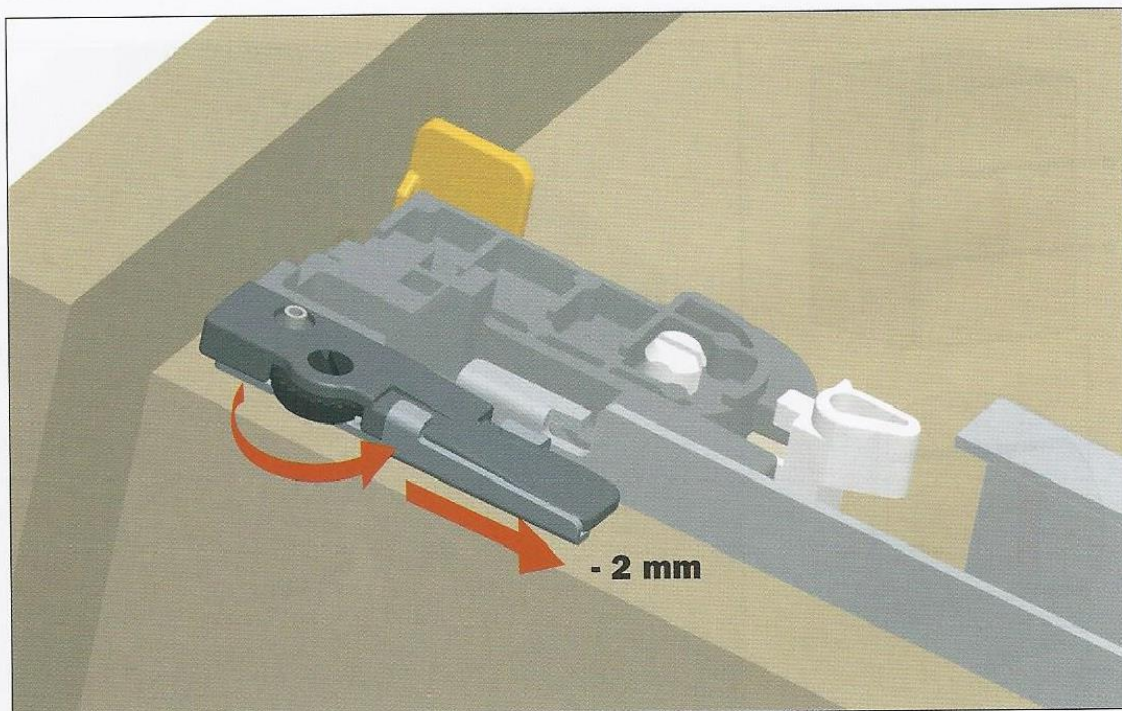
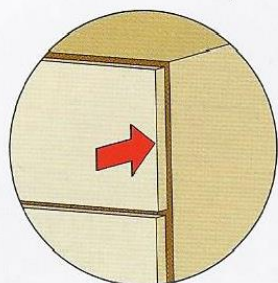
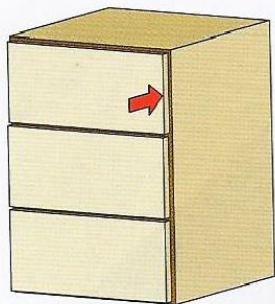

Posizione iniziale della leva per la regolazione verticale.

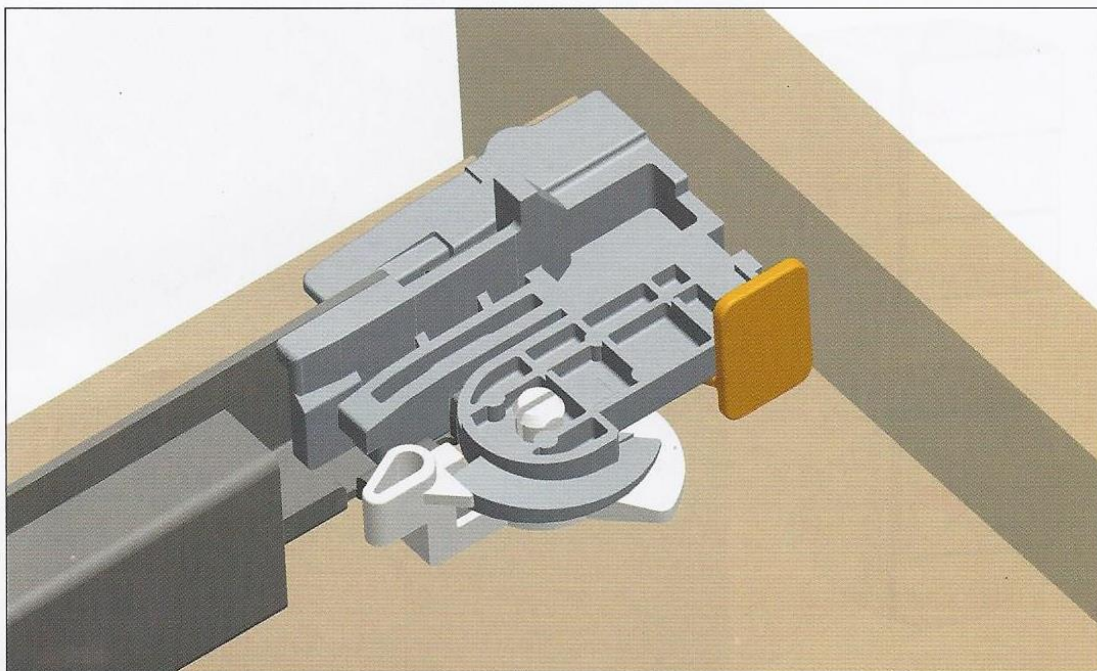
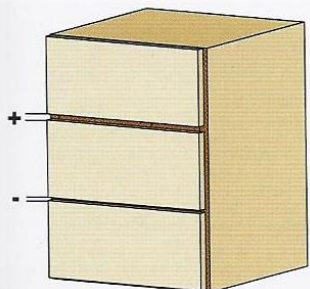

Ruotare la leva verso il frontale del cassetto per ottenere la regolazione verticale.

Questa operazione si effettua senza l'utilizzo di alcun utensile.

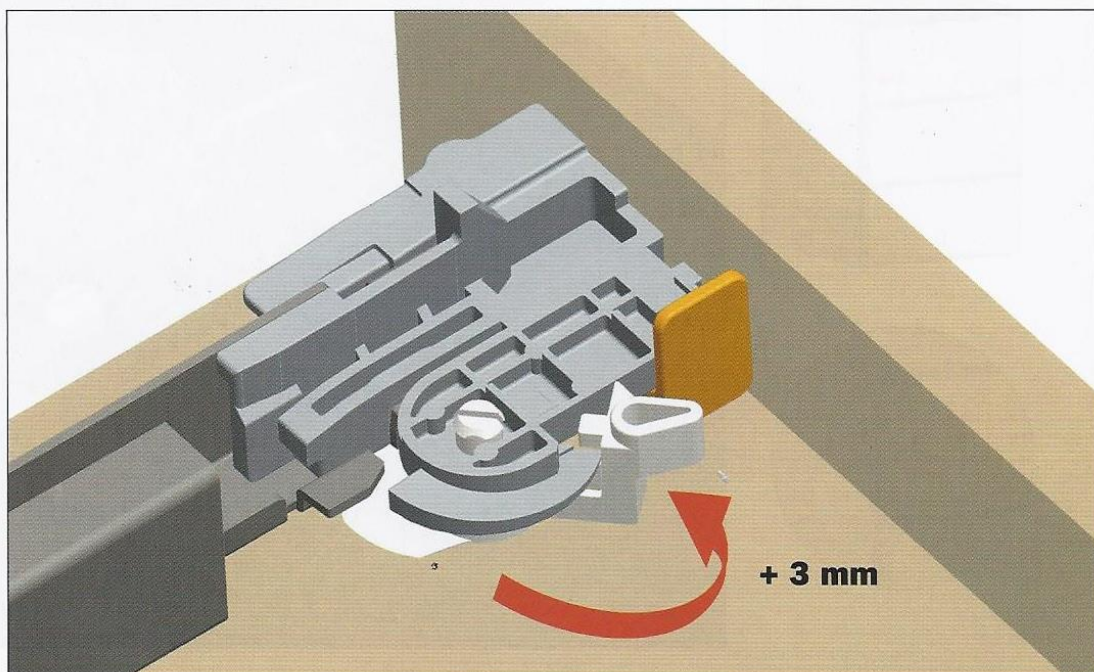
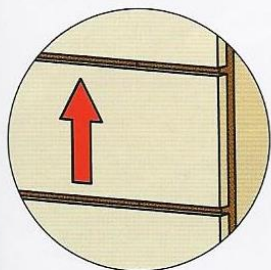
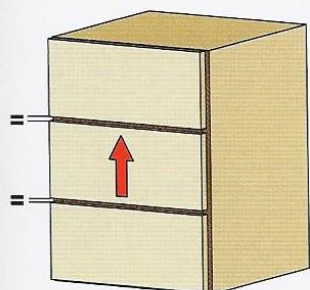

VERSIONE CON ANTE

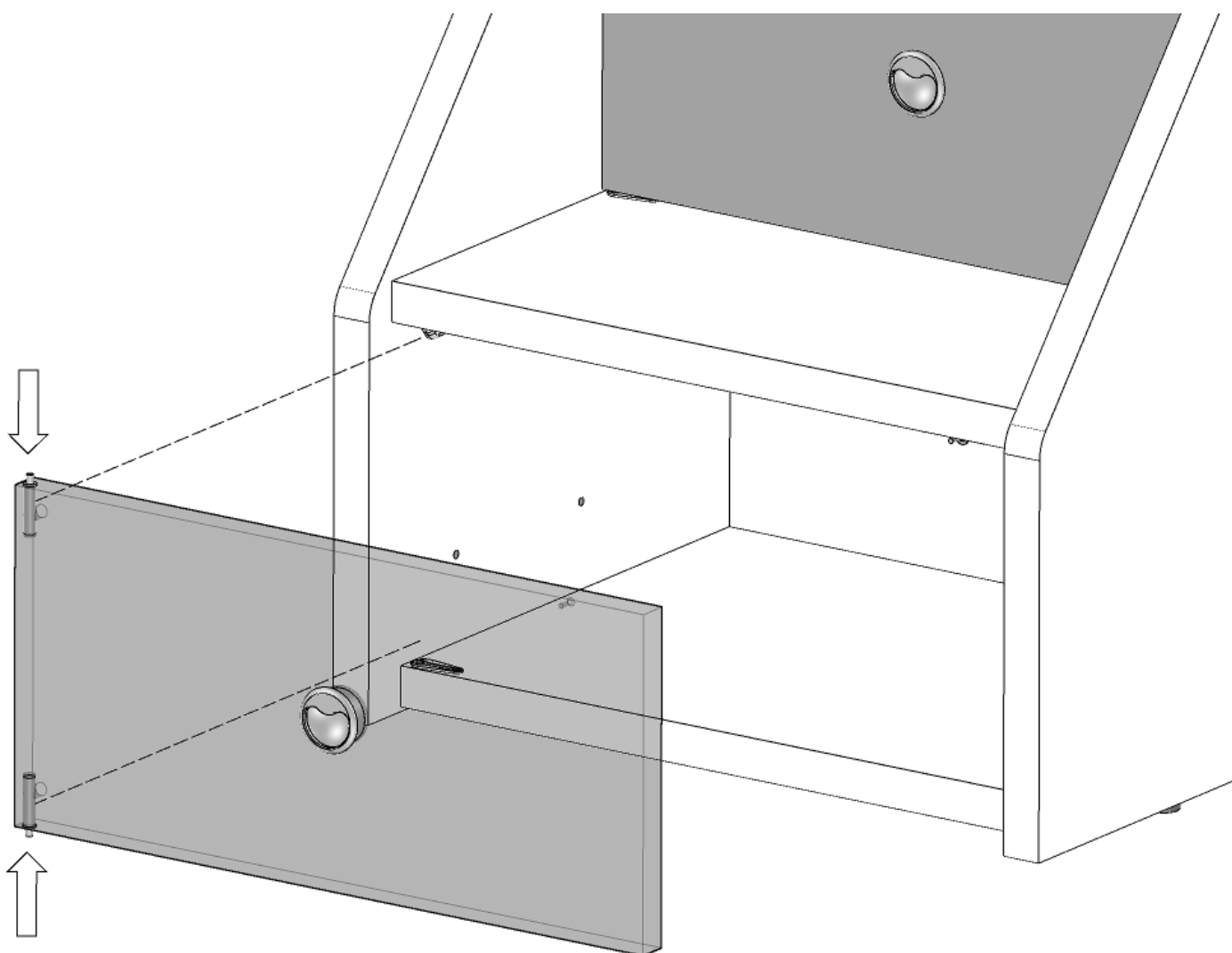

Posizionata l' anta
fissare la
regolazione con la
vite

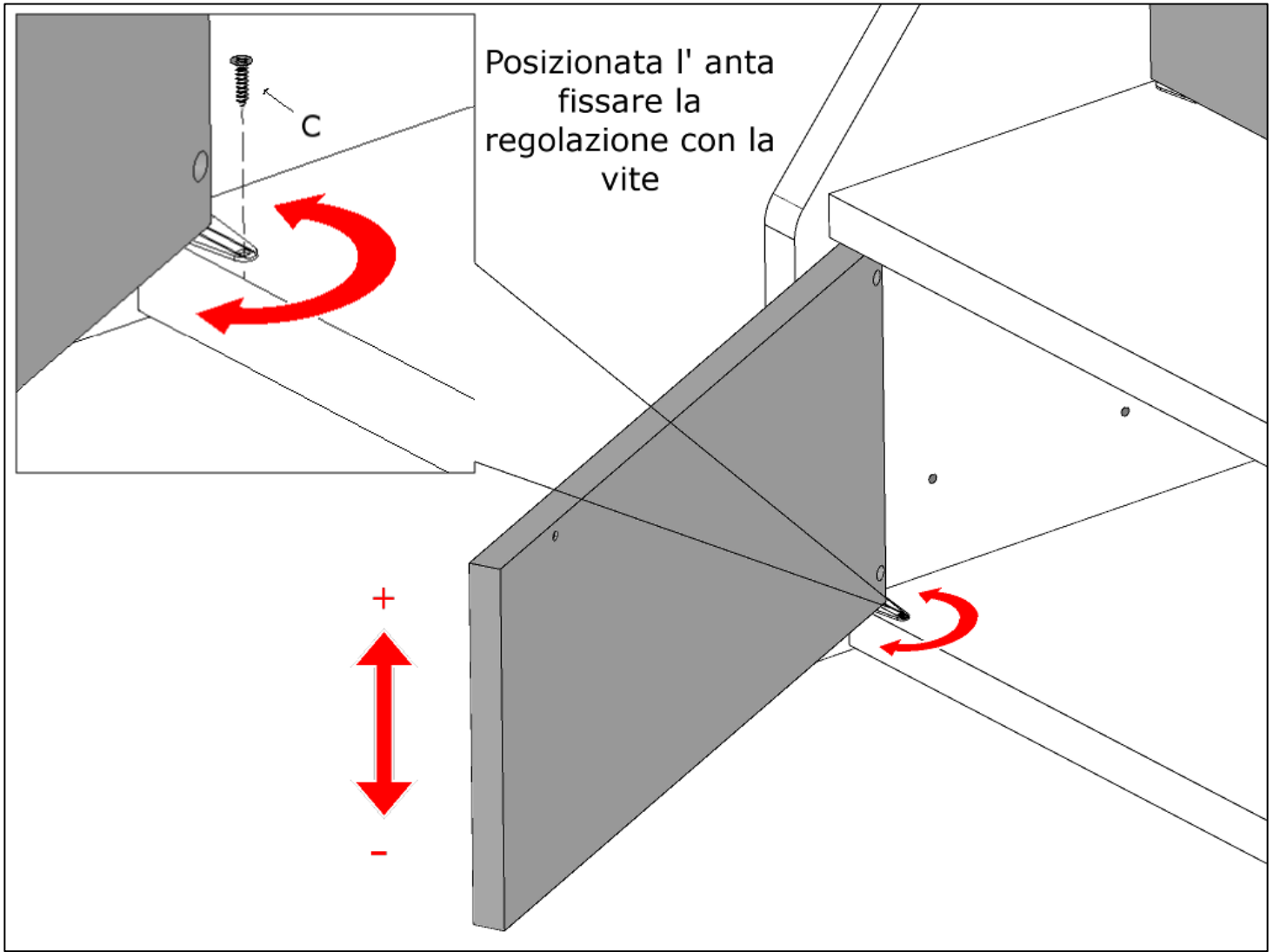

SMONTAGGIO
ANTA

