

Schemi montaggio
Assembling diagrams

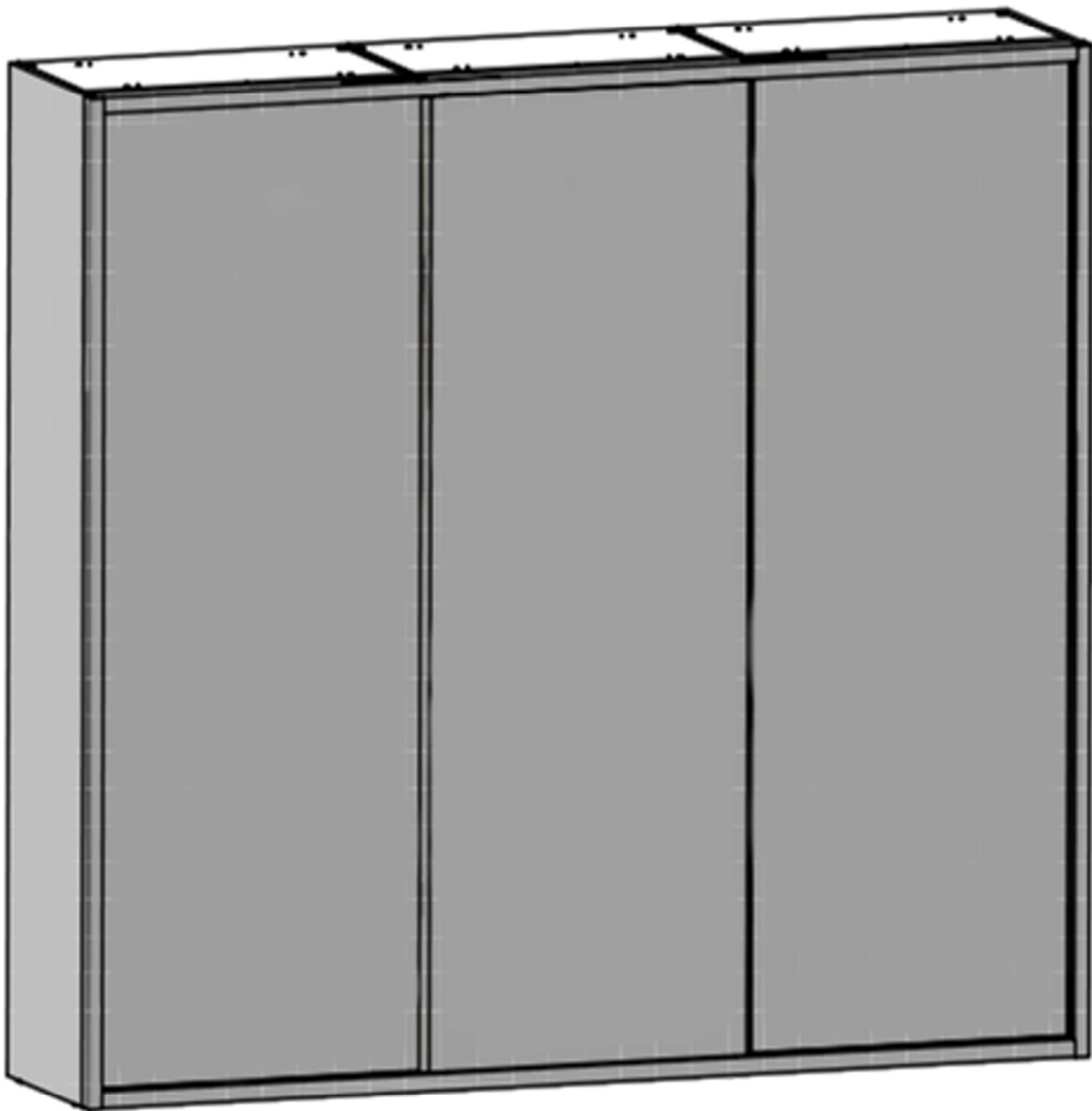







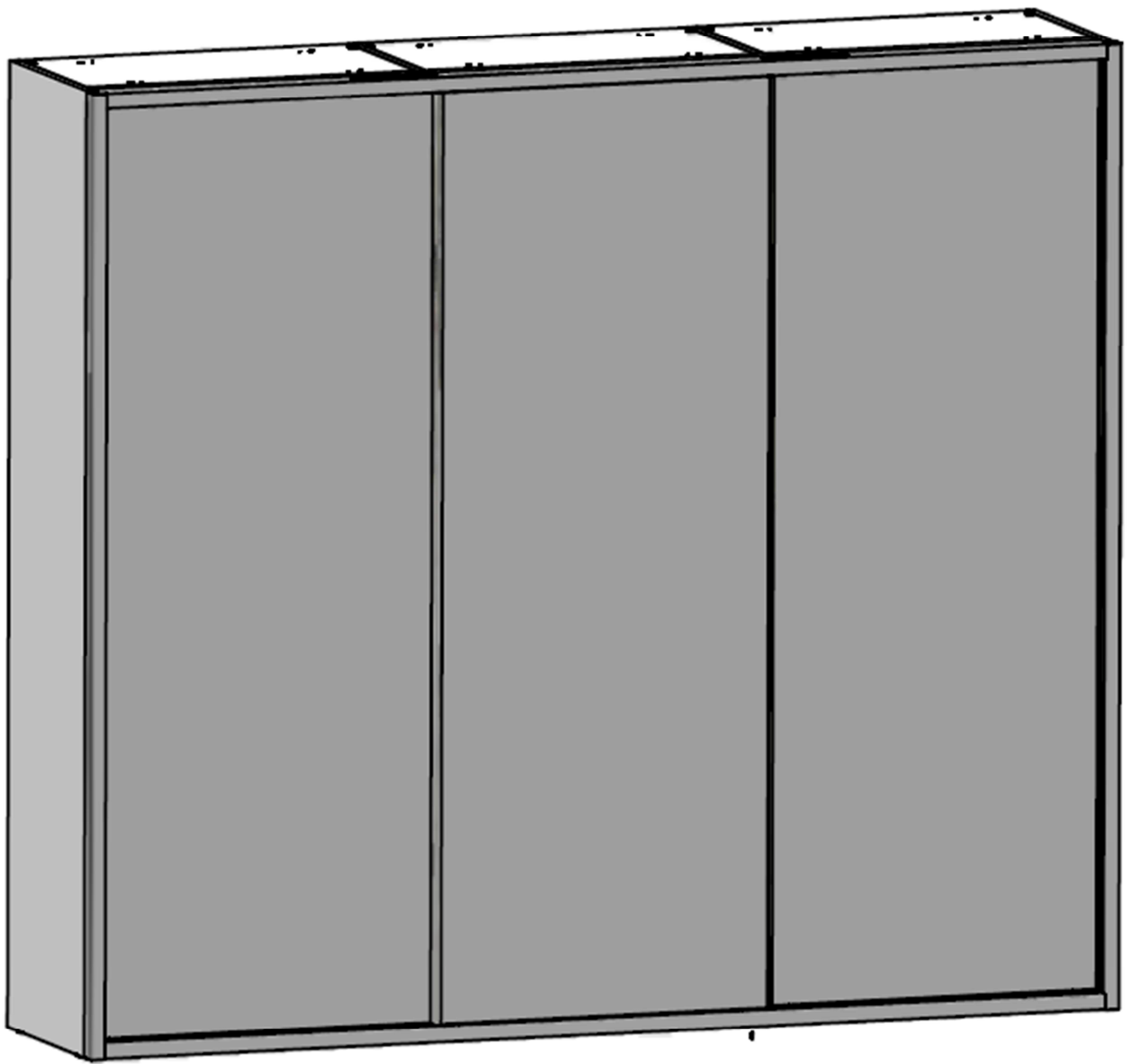





FRAME

ed. 02/2017 - rev. 2

SCMNT034



080006215__SFR_Sac.Fr.Strt.FRAME 2Ante 2.0				
200000968	A		n°6	
200000872	B		n°6	
200000974	C		n°6	
200002291	D		n°8	
200003364	E		n°4	

080006216__SFR_Sac.Fr.Strt.FRAME 3Ante 2.0				
200000968	A		n°9	
200000872	B		n°9	
200000974	C		n°9	
200002291	D		n°8	
200003364	E		n°6	

080005145 - SFR_Sac.Fr.Pied.Base.Mod.Std

200001980

A



n°4

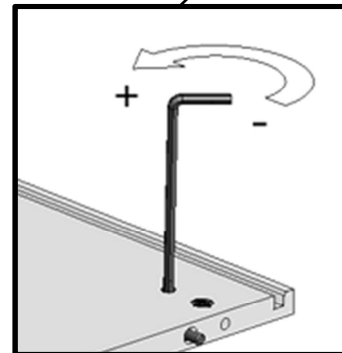
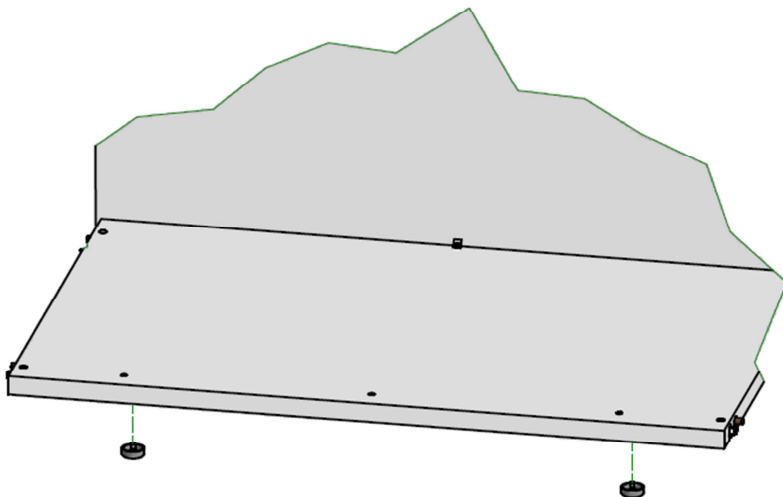
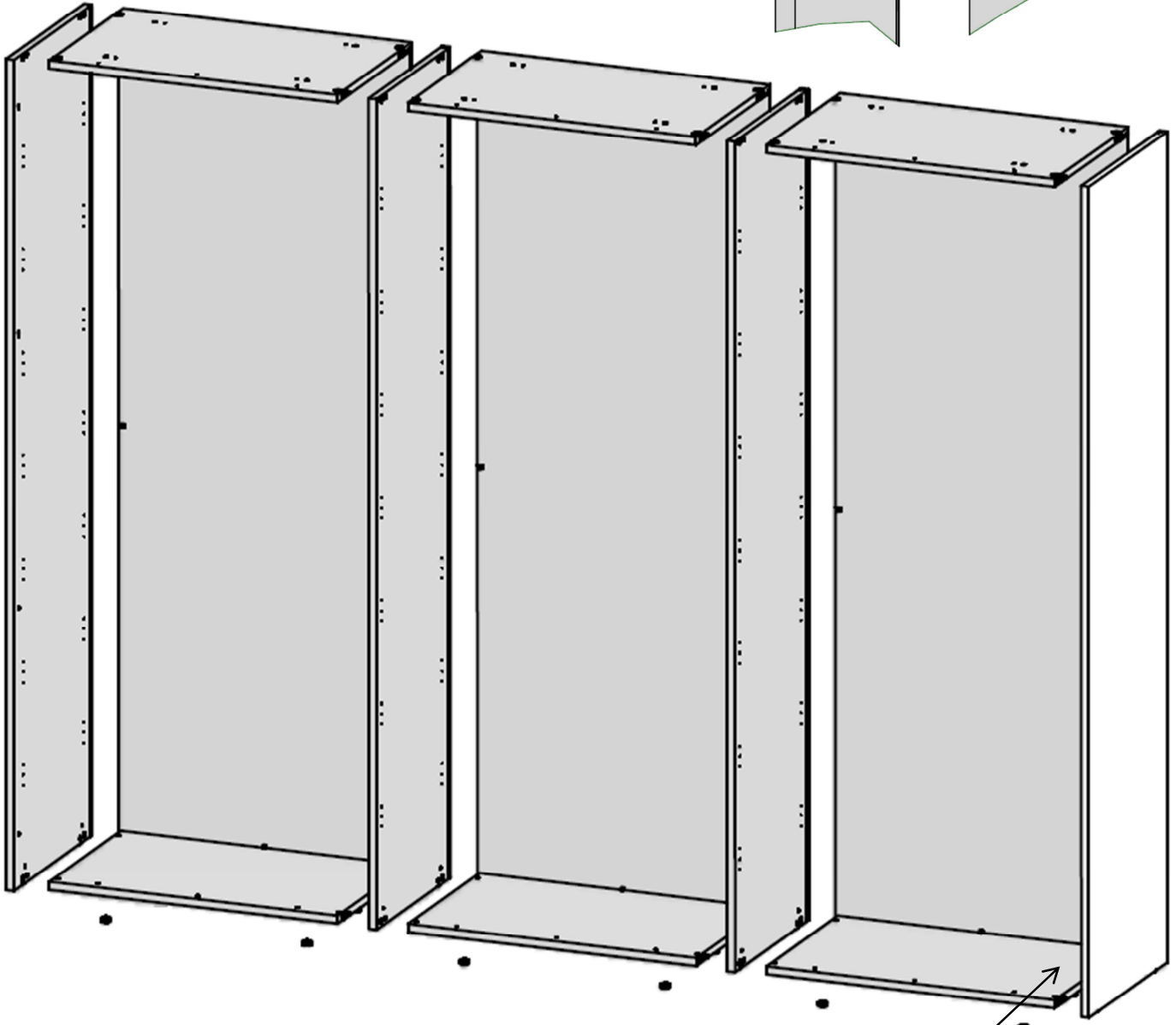
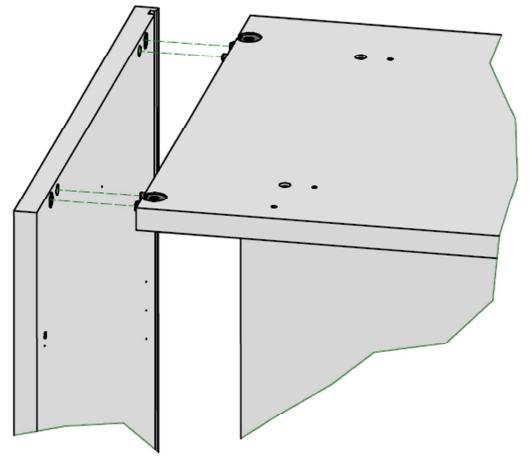

ATTENZIONE

ALLENARE IL MECCANISMO
DI SERRAGGIO DEI FIANCHI
PER PERMETTERE ALLA GUIDA
DI ENTRARE AGEVOLMENTE

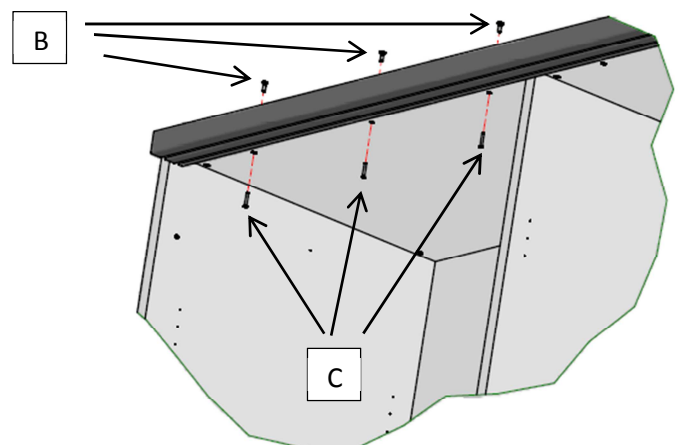
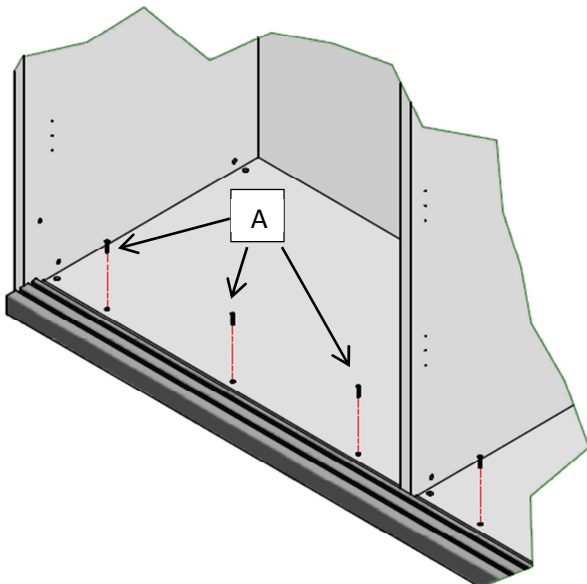
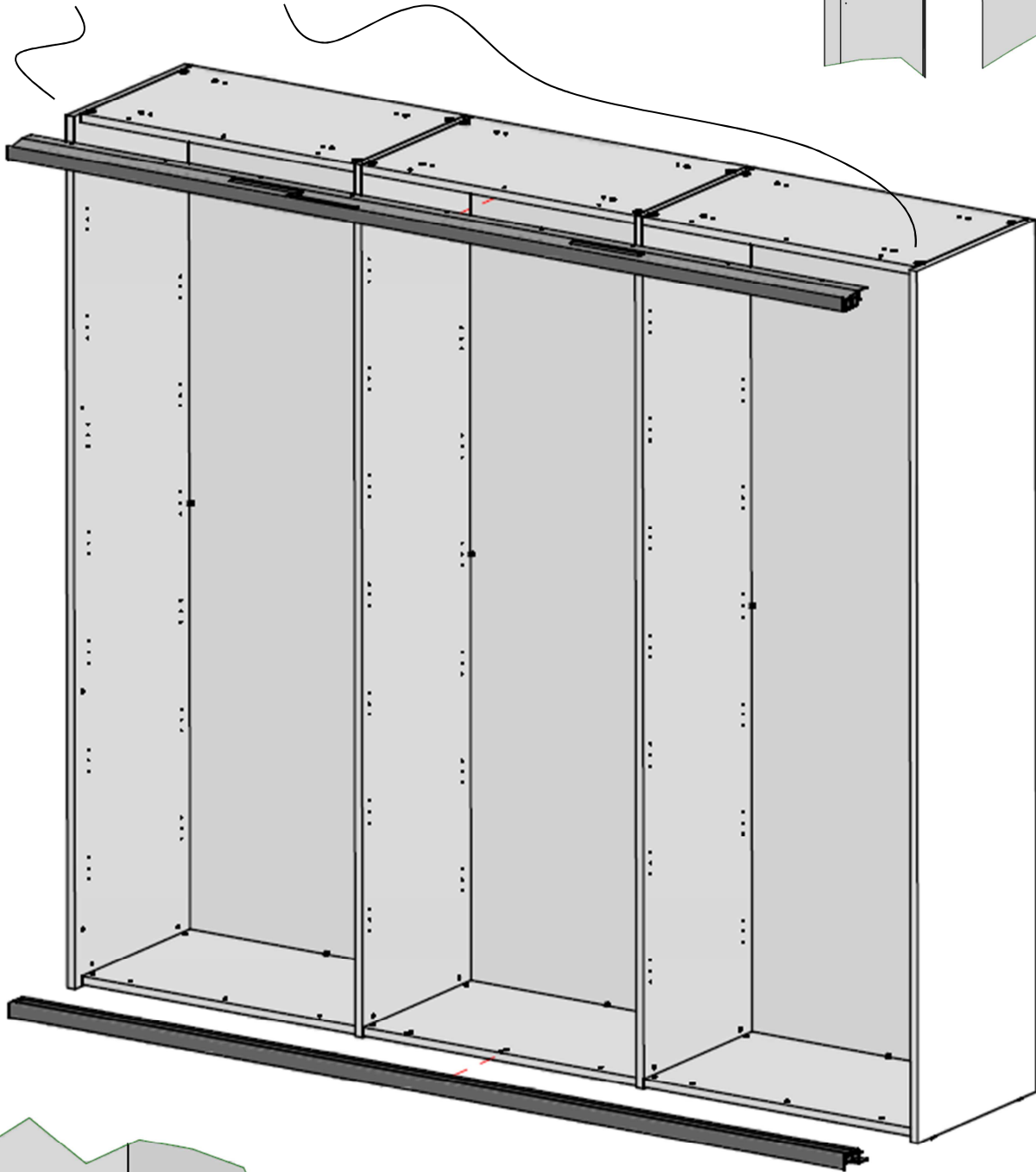
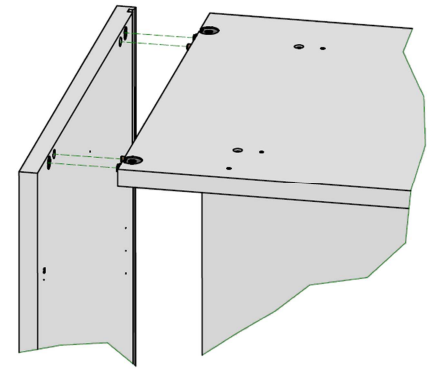
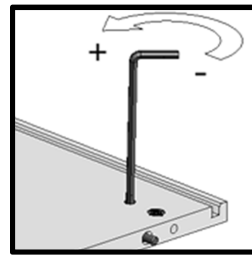
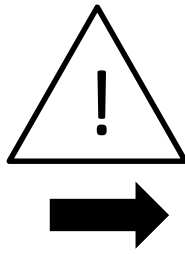

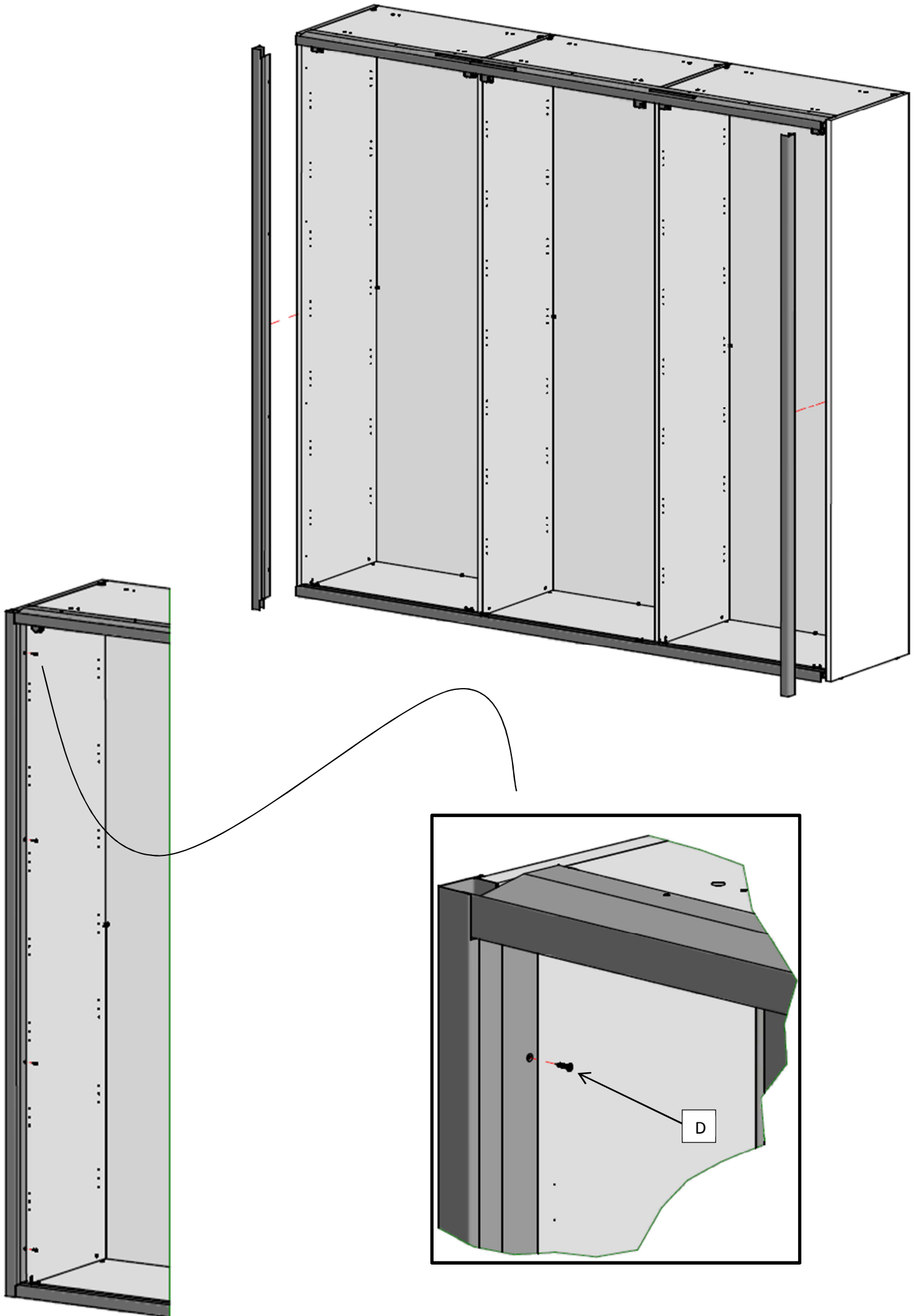

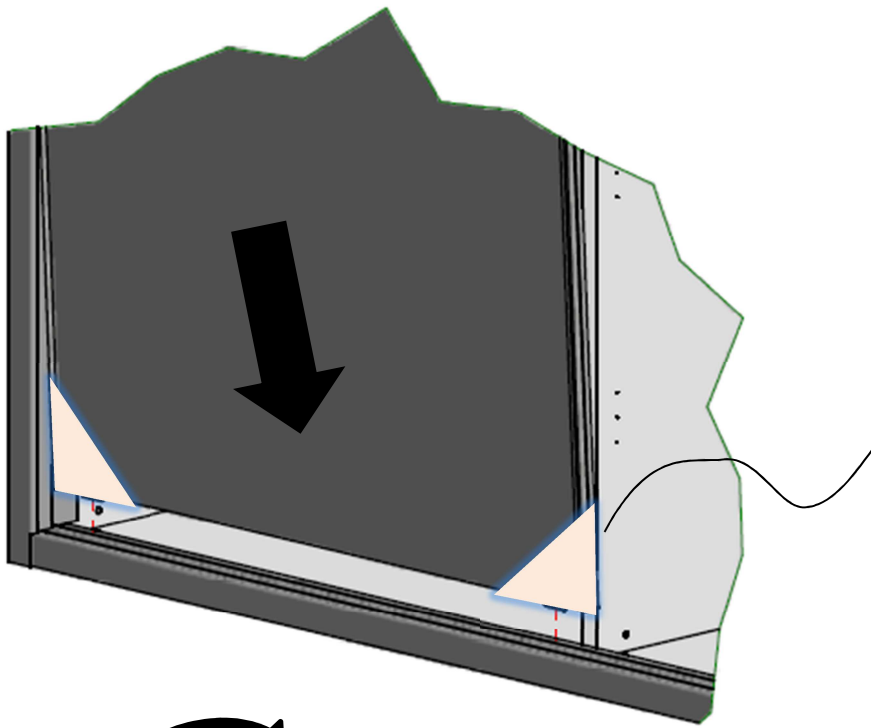

ATTENZIONE
RIMUOVERE GLI
ANGOLARI ANTI
GRAFFIO POSIZIONATI
AI LATI DELLE ANTE
SOLAMENTE DOPO
AVERLE AGGANCIATE AI
CARRELLI

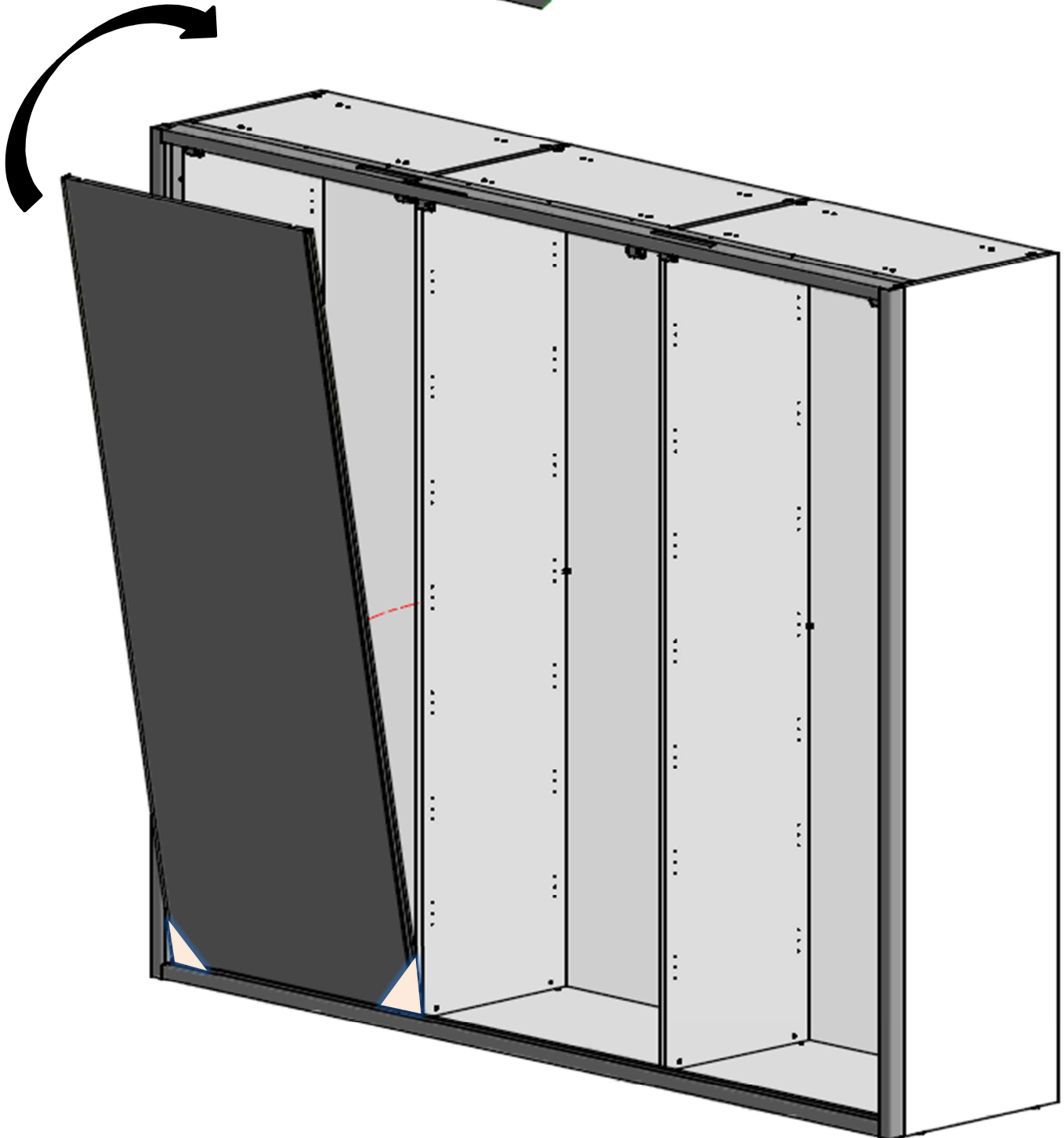

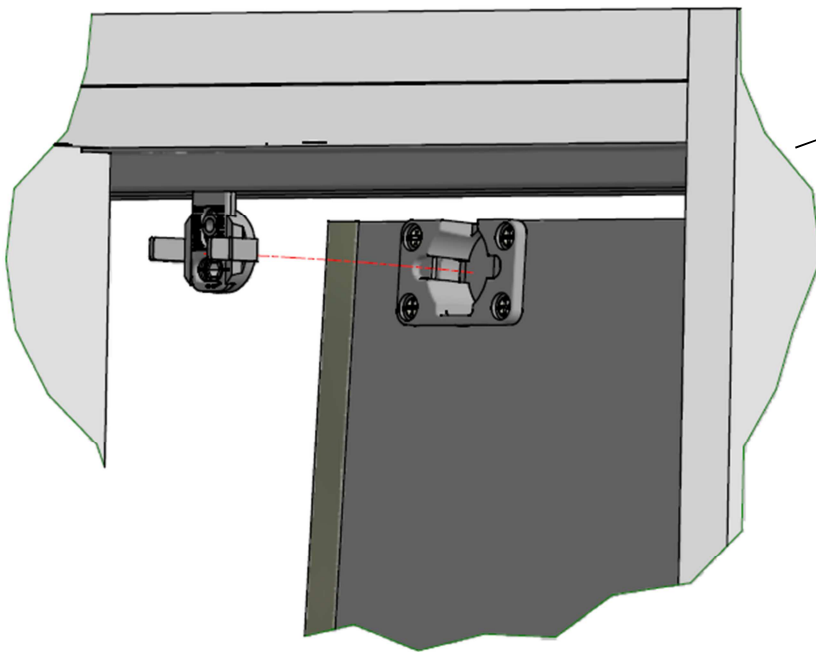

REGOLAZIONE CARRELLO

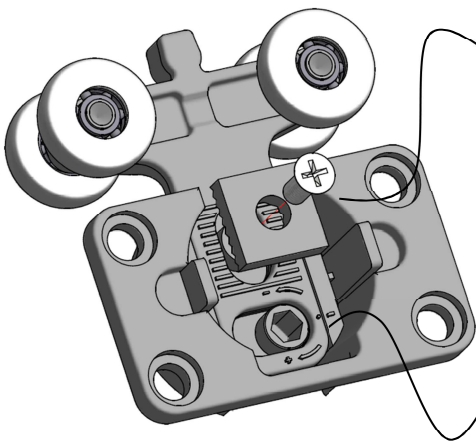

- ALLENARE LA VITE CENTRALE
- CON L'APPOSITA CHIAVE ESAGONALE ALZARE O ABBASSARE A SECONDA DELLA NECESSITA' NELLA DIREZIONE INDICATA DALE FRECCHE

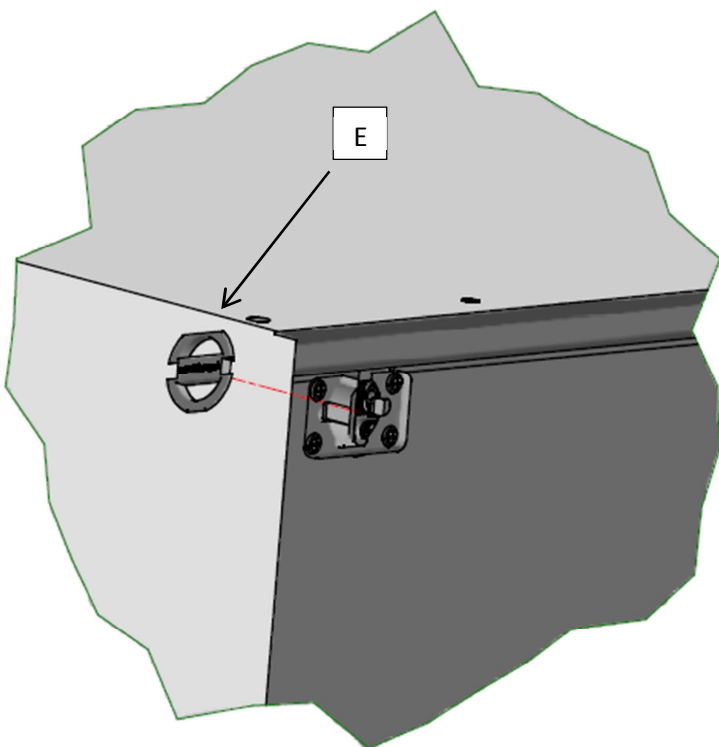
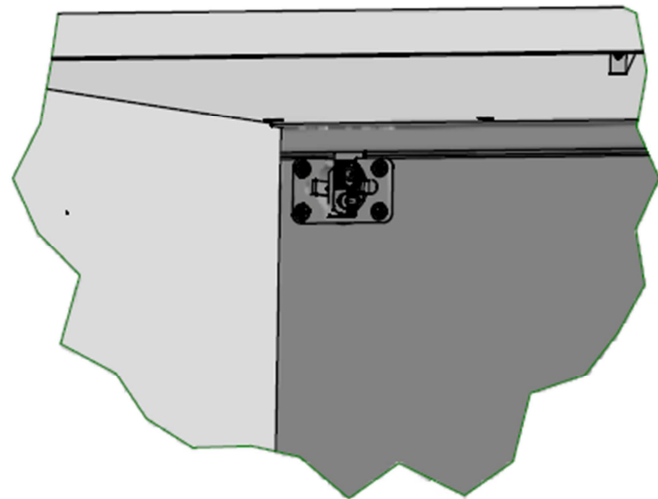

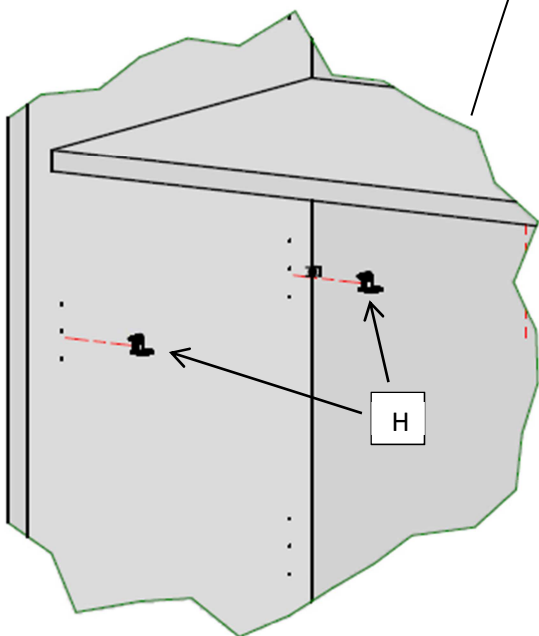
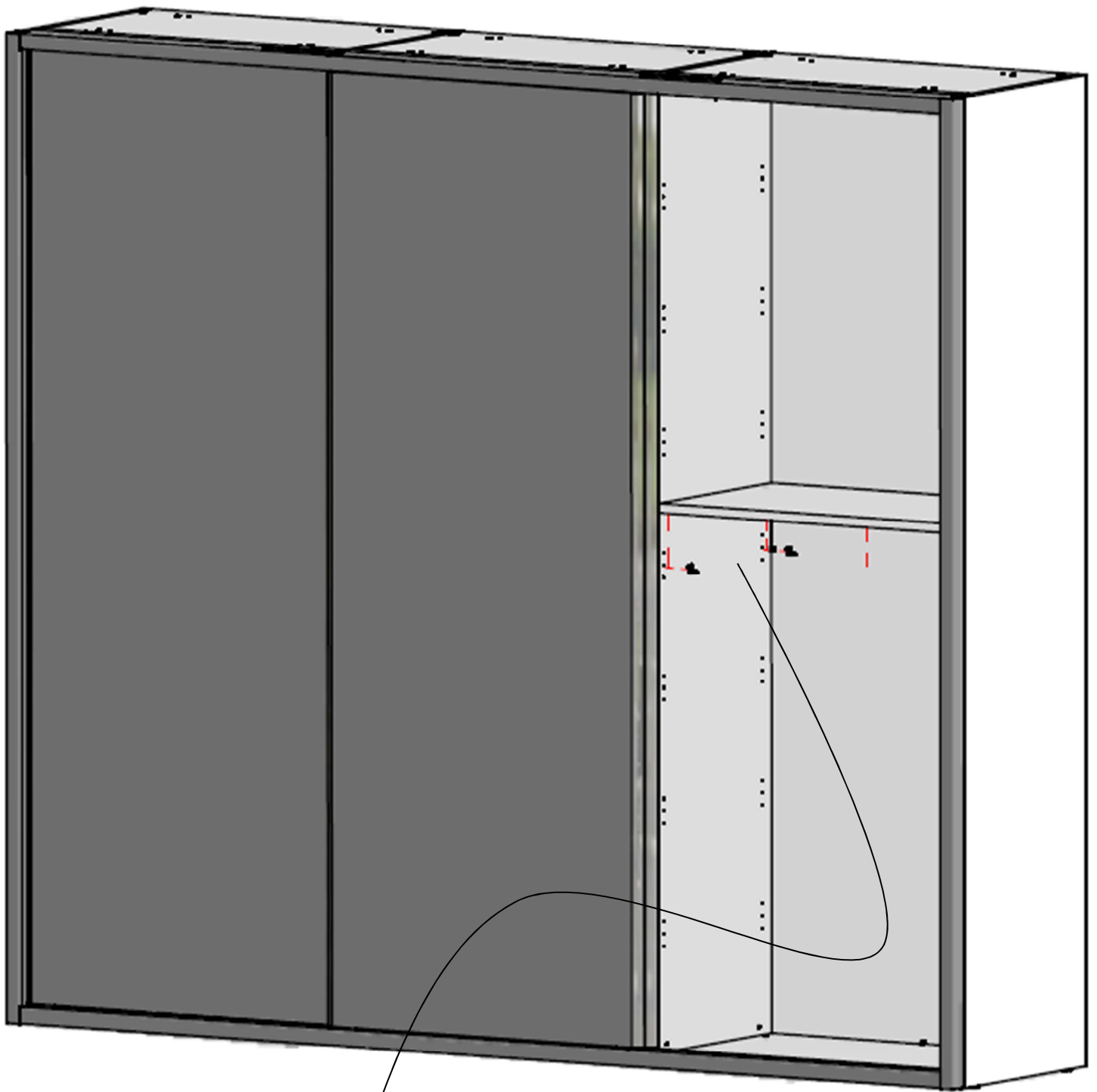

ATTENZIONE
APPLICARE IL TAPPO DI
SICUREZZA ANTI
SGANCIAMENTO SUL
CARRELLO UNA VOLTA CHE
L'ANTA E' STATA
AGGANCIATA
CORRETTAMENTE
E MESSA A LIVELLO



ATTENZIONE

PER RIUSCIRE AD INSERIRE I TAPPI DI SICUREZZA SUI CARRELLI, I RIPIANI DEVONO ESSERE MONTATI DOPO AVER INSERITO LE ANTE, POICHE' E' NECESSARIO AVERE SPAZIO DI MANOVRA ALL'INTERNO DELL'ARMADIO

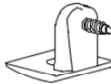
REGGIRIPIANO MODULO STANDARD

H		n°4	
---	--	-----	---

1

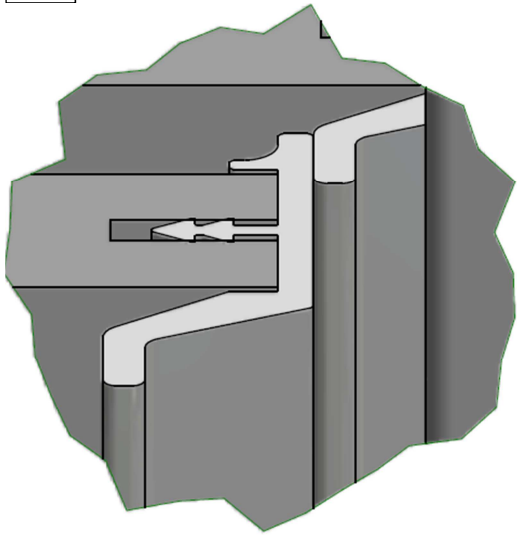

2

LASCIARE
QUALCHE
MILLIMETRO DI
LUCE TRA LE
ANTE (figura 2)
PER EVITARE CHE
LE MANIGLIE SI
DANNEGGINO

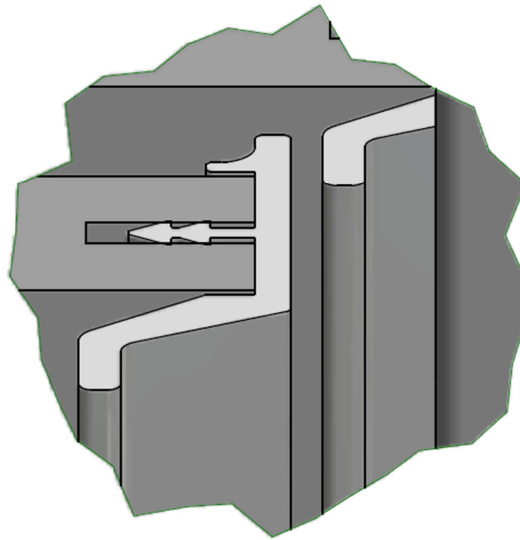

3

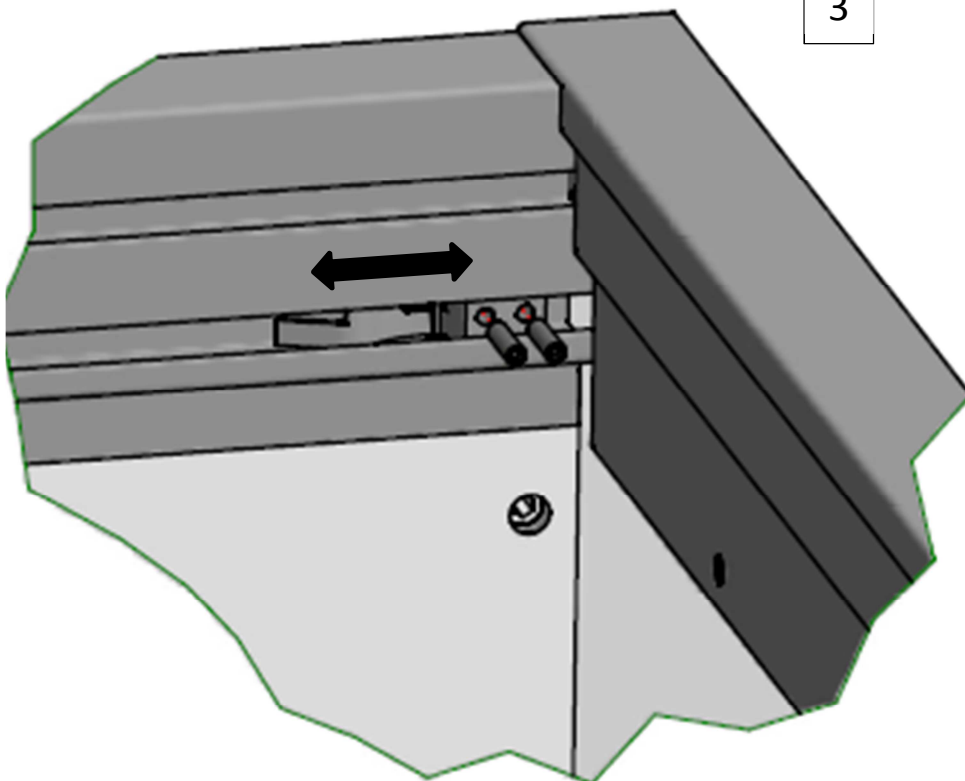

ATTENZIONE

NEL CASO IN CUI
L'ANTA ESTERNA E
QUELLA INTERNA SI
TOCCHINO (figura 1)
SARA' NECESSARIO
ANDARE A REGOLARE IL
FINE CORSA (figura 3)

PER FARLO ALLENTARE I
GRANI E SPOSTARE IL
FINE CORSE DELLA
MISURA NECESSARIA

IN FINE SERRARE
NUOVAMENTE I GRANI